

2026

zanotta:



Collection

Collection

2026

zanotta:

Indice / Index

P. 16-71

Divani / Sofas / Canapés / Sofas / Sofás

P. 74-97

Poltrone / Armchairs / Fauteuils / Sessel / Butacas

P. 100-125

Tavolini, Comodini / Small tables, Nightstands
Petites tables, Tables de chevet / Couchtische,
Nachttische / Mesitas, Mesitas de noche

P. 128-145

Sedie / Chairs / Chaises / Stühle / Sillas

P. 148-181

Tavoli, consolle, scrivanie / Tables, console tables, desks
tables, consoles, tables bureau / Tische, wandtische,
schreibtische / Mesas, consolas, mesas escritorios

P. 184-201

Letti, materassi, reti / Beds, mattresses, springing /
Lits, matelas, sommiers / Betten, matratten,
lattenroste / Camas, colchones, somieres

P. 204-233

Complementi d'arredo / Furnishing accessories
Compléments d'ameublement / Wohnaccessoires
Complementos de decoracion

P. 236-243

Contenitori / Sideboards / Containers de rangement
Sideboards / Muebles contenedores

P. 246-249

Specchi / Mirrors / Miroirs / Spiegel / Espejos

Prodotti / Products

A

Albero P.204
Alfa P.16
Alfarè P.100 NEW
Allunaggio P.205
April P.128
Ara Fenice P.206
Arabesco CM P.101
Ardea CM P.74
Arom P.75
Aster P.207

B

Basello P.102
Battito P.208 NEW
Binata P.129 NEW
Bol P.148-150
Bumper P.20

C

Calamo P.153
Calla P.76
Campa P.130 NEW
Campa P.154 NEW
Carlino CM P.103
Cavour CM P.156
Celestina P.132
Chichibio P.209
Club P.24
Comacina P.158
Confortevole P.200
Cuculia P.210
Cumano P.104

D

Dealbata P.211
Derby P.77

E

Ettaro P.212
Ettaro P.213 NEW

F

Fedrigio P.26
Fenice P.159
Fenis CM P.133
Flamingo P.30
Follia P.214
Formaplus P.200

G

Galeotta P.78
Genni P.79
Gilda CM P.80
Giotto P.215
Girò P.105
Giuno P.134
Gomma P.81
Grangala P.184
Graphium P.106

J

Joy P.216

K

Karelia P.82
Kent P.83
Kilt / Kilt 84 P.34

L

Lama P.84
Lazy Susan P.152
Lea P.135
Lealta P.136
Lenzuola P.201
Leonardo P.160
Lia P.137
Lialta P.138
Lio/Leo P.139
Low Bol P.107 NEW

M

Maggiolina P.85
Marcuso P.161-162
Mezzadro P.217
Milano P.186
Milano+ P.38
Milo CM P.246
Mollaplust P.200
Molleggio P.200
Museo P.218

N

Nagori P.188 NEW
Natura P.200
Nellee P.140
Nena P.141
Nena Lounge P.86
Nena Stool P.142
Noah P.40
Nyx P.190

O

Oliva P.87
Oscar P.108

P

Parco P.46
Pianoalto+ /
Pianoalto+ 96 P.48
Pisolo P.201
Poker P.163
Primate P.219

Q

Quaderna Carpet P.220
Quaderna Coffee
Table P.109
Quaderna Consolle P.167
Quaderna
Cupboard P.236
Quaderna Desk P.165
Quaderna Mirror P.247
Quaderna
Sideboard P.237
Quaderna Small
Table P.110
Quaderna Table P.164
Quaderna
Writing Desk P.166

R

Raperonzolo P.248
Reale P.168
Reale CM P.170
Reti letto P.201
Ricordi P.192
Riga-Riga P.172-238-239
Rondevù P.88 NEW

S

Sacco P.90
Sacco Medium P.90
Sacco Small P.90
Sant'Elia P.92
Sciangai P.221
Sciangai 50 P.222
Sella P.223
Servento P.224
Servietto P.225
Servobandiera P.226
Servofumo P.227
Servomanto P.228
Servomuto P.111
Servonotte P.225
Servopluvio P.227
Servostop P.229
Shiki P.54
Slice me nice P.112 NEW
Sosia P.249
Susanna P.93

T

Ta.Ba.Ce. P.113
Talamo P.194
Talamo Box P.196
Talia P.144
Taschino P.114
Tempo P.115
Teti P.116
Thar P.230
Throw-Away P.58
Tidone P.173
Tod P.117
Toi P.118
Tonietta P.145
Topper P.200

Toto P.119
Tweed P.174-176
Tweed Marble P.177
Tweed Mini P.120-121

V

V-Bol P.231
Vertebra P.178 NEW

W

William P.60
William+ P.66

Y

Yori-Kiri P.94

Z

Zavolo Coffee Table P.123
Zavolo Consolle P.180
Za:Za P.68
Za:Za Bed P.198-199
Za:Za Max P.70
Zeus P.124
Zymmo P.96-125
Z24 P.242
Z24 Books P.232
Z24 Nightstand P.122
Z24 Cupboard P.240
Z24 Sideboard P.241

Ambienti / Spaces

Living

Sofas

Alfa
Bumper
Fedrigo
Flamingo
Kilt / Kilt 84
Milano+
Noah
Pianoalto+ / Pianoalto+ 96
Shiki
Throw-Away
William
William+
Za:Za
Za:Za Max

Armchairs

Ardea CM
Arom
Calla
Derby
Galeotta
Genni
Gilda CM
Gomma
Karelia
Kent
Lama
Maggiolina
Nena Lounge
Oliva
Rondevù
Sacco

Sant'Elia

Susanna
Yori-Kiri
Zymmo

Small tables

Alfarè
Arabesco CM
Basello
Carlino CM
Cumano
Girò
Graphium
Low Bol
Quaderna Coffee Table
Quaderna Small Table
Servomuto
Slice me nice
Ta.Ba.Ce.
Tempo
Teti
Tod
Toi
Toto
Tweed Mini
Zavolo Coffee Table
Zeus
Zymmo

Furnishing accessories

Albero
Ara Fenice
Aster

Battito

Chichibio
Cuculia
Dealbata
Ettaro
Follia
Giotto
Joy
Mezzadro
Museo
Primate
Quaderna Carpet
Sciangai / Sciangai 50
Sella
Servomanto
Thar
V-Bol
Z24 Books

Mirrors

Milo CM
Quaderna Mirror
Raperonzolo
Sosia

Sideboards

Quaderna Cupboard
Quaderna Sideboard
Riga-Riga Cupboard
Riga-Riga Sideboard
Z24 Cupboard
Z24 Sideboard

Dining

Chairs / Armchairs

April
Arom
Binata
Calla
Campa
Celestina
Fenis CM
Giuno
Lea / Lia
Lealta / Lialta
Lio / Leo
Nellee
Nena
Nena Stool
Talia
Toniotta

Tables

Bol
Campa
Fenice
Marcuso
Quaderna Table
Reale
Reale CM
Riga-Riga
Tidone
Tweed
Tweed Marble
Vertebra

Furnishing accessories

Albero
Ara Fenice
Battito
Carlino CM
Chichibio
Cuculia
Dealbata
Ettaro
Joy
Mezzadro
Thar
V-Bol
Zavolo Consolle
Z24 Books

Mirrors

Milo CM
Quaderna Mirror
Raperonzolo
Sosia

Sideboards

Quaderna Cupboard
Quaderna Sideboard
Riga-Riga Cupboard
Riga-Riga Sideboard
Z24 Cupboard
Z24 Sideboard

Sleeping

Beds

Grangala
Milano
Nagori
Nyx
Ricordi
Talamo
Talamo Box
Za:Za Bed

Furnishing accessories

Aster
Battito
Museo
Sciangai 50
Sciangai
Servomanto
Servonotte
Servietto

Mirrors

Milo CM
Quaderna Mirror
Raperonzolo
Sosia

Sideboards

Z24 Chest of Drawers

Nightstand / Small tables

Basello
Carlino CM
Cumano
Oscar
Servomuto
Taschino
Tempo
Tod
Toi
Z24 Nightstand
Zymmo

Outdoor

Sofas

Club
Parco

Chairs

April
Sacco

Small tables

Ta.Ba.Ce.
Teti
Zeus

Furnishing accessories

Allunaggio
Servofumo
Servopluvio
Servobandiera

Home Office

Desks

Comacina
Cavour CM
Calamo
Quaderna Desk
Quaderna Writing Desk

Chairs / Armchairs

Calla
Giuno
Nena

Furnishing accessories

Z24 Books

Designers

A

Monica Armani
Atelier Oi
Gae Aulenti

B

Roberto Barbieri
Liisi Beckmann
Simone Bonanni
Piero Bottoni
Todd Bracher
Brogliato Traverso

C

Calvi Brambilla
Achille e Pier Giacomo Castiglioni
Achille Castiglioni
Pierre Charpin
Joe Colombo

D

De Pas – D'Urbino – Lomazzi
Anna Deplano
Alessandro Dubini
Noé Duchaufour Lawrance

E

Emaf Progetti

G

Garcia Cumini
Gatti – Paolini – Teodoro
Constance Guisset

I

Salvatore Indriolo

L

Ugo La Pietra
Willie Landels
Francesca Lanzavecchia
Lanzavecchia + Wai
Bertrand Lejoly
Gino Levi Montalcini

M

Philippe Malouin
Enzo Mari
Carlo Mollino
Gabriele Mucchi
Muller Van Severen

P

Giuseppe Pagano Pogatschnig
Ludovica Serafini + Roberto Palomba

R

Prospero Rasulo
Gabriele Rosa

S

Spalvieri & Del Ciotto
Studiopepe
Superstudio

T

Giuseppe Terragni

V

Vincent Van Duysen

W

Damian Williamson
Christian Woo

Z

Marco Zanuso
Zaven



Sofas

16-71

Divani
Canapés
Sofas
Sofás



Design

Emaf Progetti

1999

Poltrona, divani monoblocco, componibili, pouf
Piedini in acciaio cromato, o nichel-satinato colore naturale o nero, oppure verniciato colore grafite. Struttura in acciaio. Molleggio su nastri elastici. Imbottitura in poliuretano/ fibra poliestere termolegata. Rivestimento sfilabile in stoffa o in pelle, con cuscino seduta trapuntato. Cuscinetti in Dacron Du Pont o piumino d'oca.

Armchair, monobloc, modular sofas, poufs
Steel feet, chromium-plated or varnished graphite, or with natural or black nickel-satin finish. Steel frame. Elastic strips suspension. Upholstery in polyurethane/ heat-bound polyester fibre. Fabric or leather removable cover with quilted seat cushion. Small cushions in Dacron Du Pont or in goose down.

Fauteuil, canapés monoblocs, composables, poufs
Pieds en acier chrome ou nickel satiné, dans les couleurs naturel ou noir, ou verni couleur graphite. Structure en acier. Suspension sur sangles élastiques. Rembourrage en polyuréthane/fibre polyester liée à chaud. Revêtement avec coussin assise surpiqué, déhoussable en tissu ou en cuir. Coussinets en Dacron Du Pont ou en duvet d'oie.

Sessel, einteilige – zusammenstellbare Sofas, Hocker
Füße aus Stahl, verchromt oder mit naturfarben- oder schwarz- vernickeltem und mattiertem Finish oder Graphit lackiert. Gestell aus Stahl. Federung mit elastischen Gurten. Polsterung aus Polyhurethan/ wärmegebundener Polyesterfaser. Abnehmbarer Bezug mit Steppung über den Sitzpolstern aus Stoff oder Leder. Kleine Kissen aus Dacron Du Pont oder aus Gänsedaunen.

Butaca, sofás monobloque, modulares, púfs
Pies de acero cromado, o niquelado mate en los acabados natural o negro o pintado color grafite. Estructura de acero. Suspensión sobre cintas elásticas. Acolchado de poliuretano/fibra poliéster termounida. Tapizado desenfundable de tejido o de piel, con cojín del asiento respuntado. Cojines de Dacron Du Pont o de plumón de ganso.

Piedini/Feet/Pieds/Füße/Patas



1326/102A

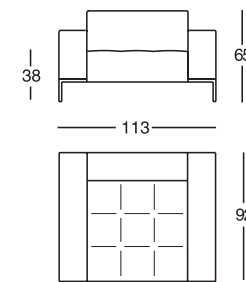

1326/202A

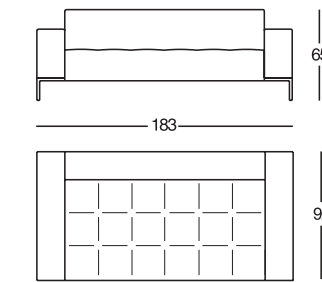

1326/212A

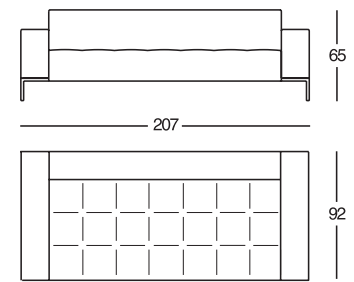

1326/302A

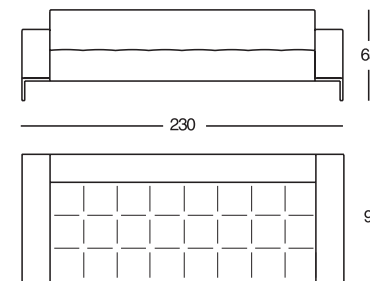

1326/POUF

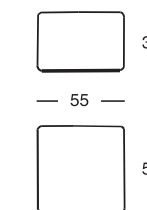

1326/POUF 1A

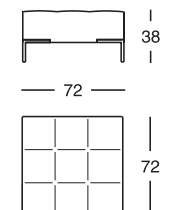

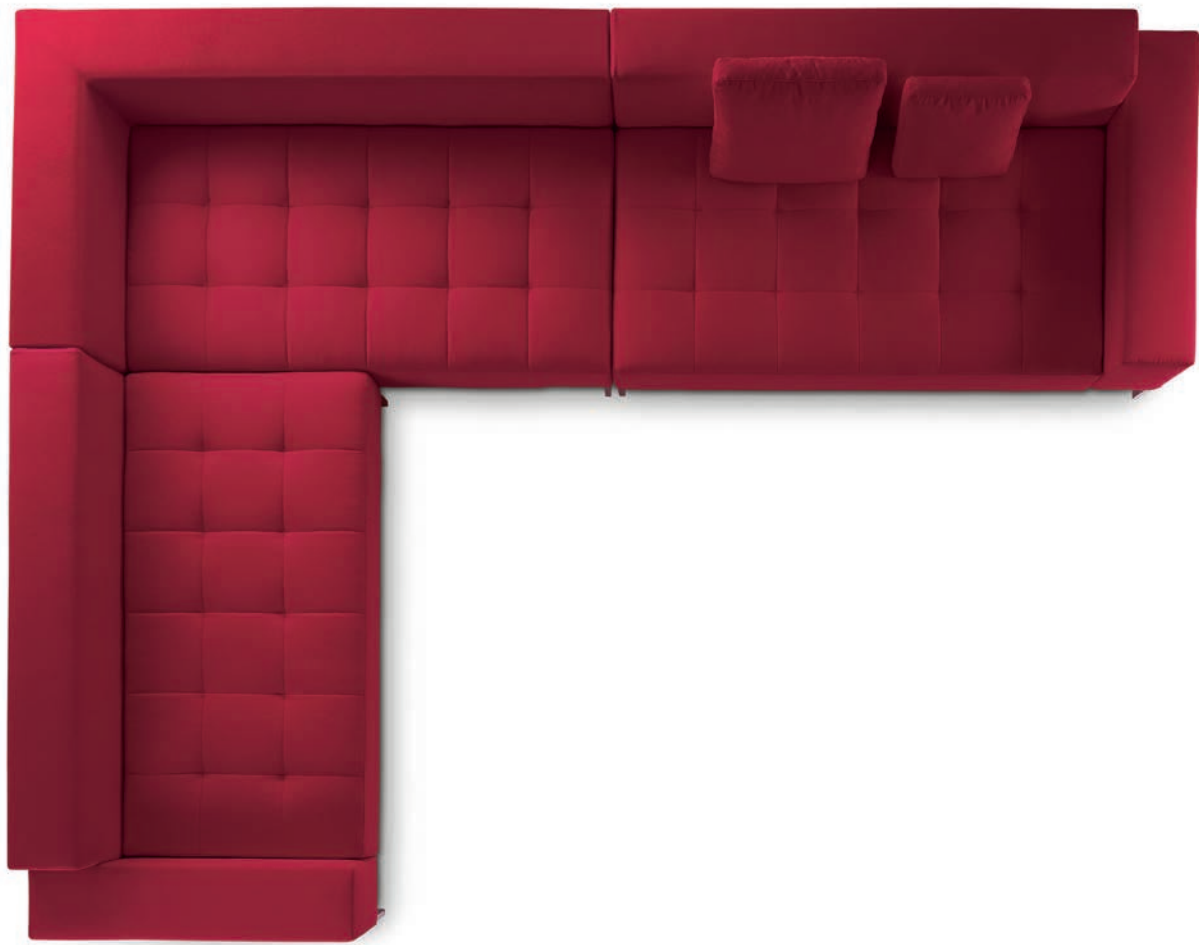

1326/201TA

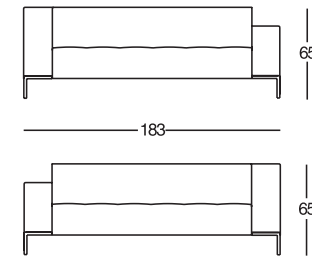

1326/301TA

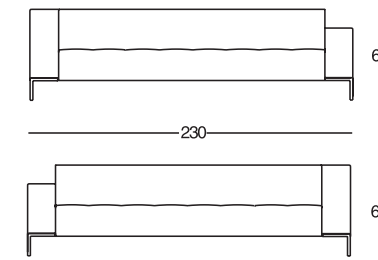

1583

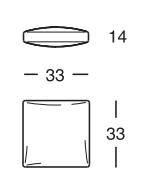

1584

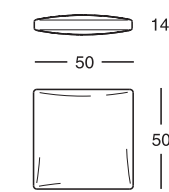

1585

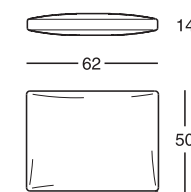

1326/DORA

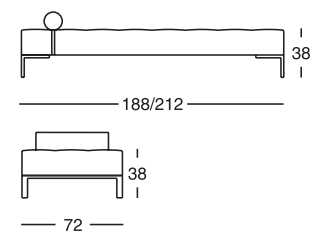

1.

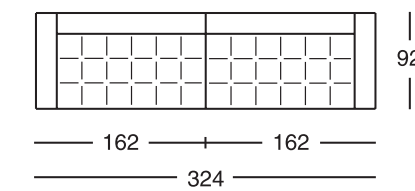

2.

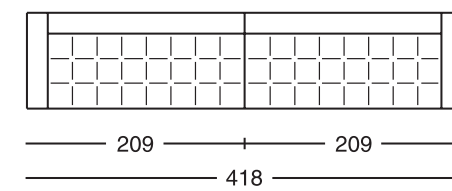

3.

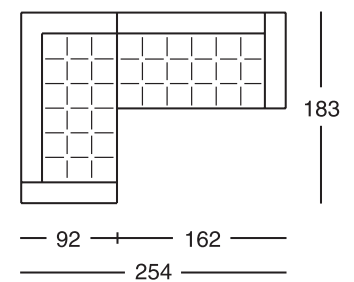

4.

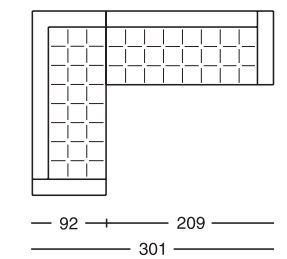

5.

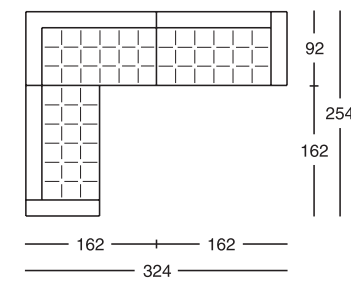

6.

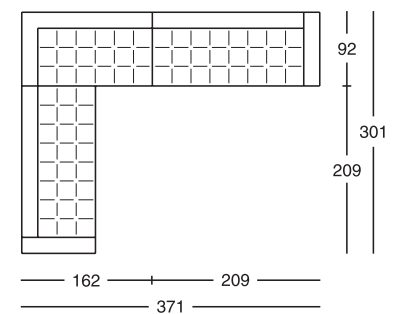

1326/POUF2A

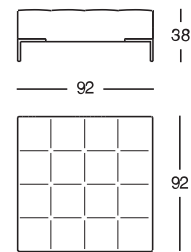

1326/AL1

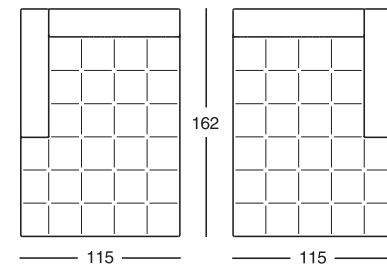

1326/ALP1

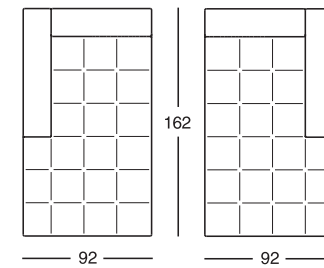

1326/ANGA

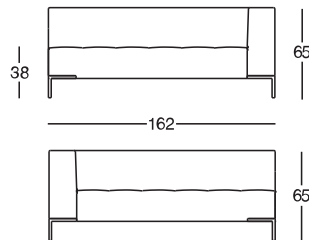

1326/201A

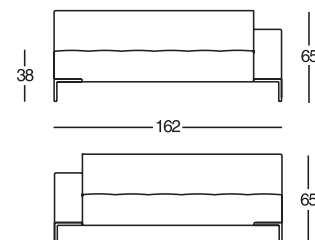

1326/301A

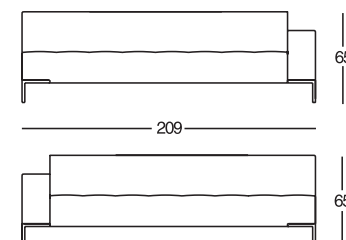

7.

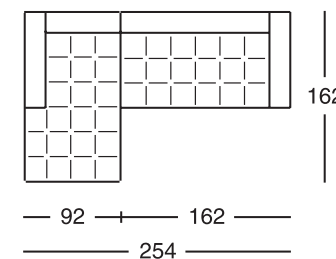

8.

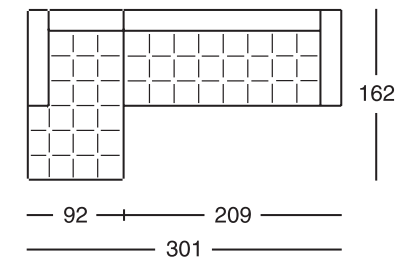

9.

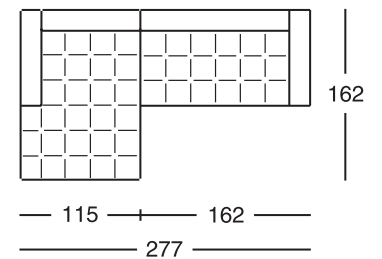

10.

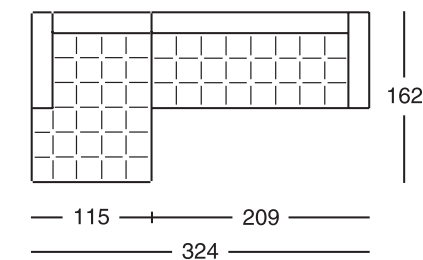

Bumper¹²⁶⁵



Design

Calvi Brambilla

2023

Divani monoblocco e componibili, pouf e cuscino
Struttura in legno. Molleggio su nastri elastici. Imbottitura sedile, schienale e base in poliuretano a quote differenziate/ Dacron Du Pont. Cuscino in fiocchi di poliestere rigenerato e rigenerabile. Rivestimento sfilabile in stoffa.

Monobloc and modular sofas, pouf and cushion
Wooden frame. Elastic strips suspension. Seat, back and base upholstered in graduated polyurethane/ Dacron Du Pont. Cushion in regenerated and regenerable polyester flakes. Removable fabric cover.

Canapés monoblocs et composables, pouf et coussin
Structure en bois. Suspension sur sangles élastiques. Rembourrage assise, dossier et base en polyuréthane à densité variable/ Dacron Du Pont. Coussin en flocons de polyester régénérés et régénérables. Revêtement déhoussable en tissu.

Einteilige und zusammenstellbare Sofas, Hocker und Kissen
Gestell aus Holz. Federung auf elastischen Gurten. Sitz-, Rücken- und Basispolsterung aus Polyurethan mit unterschiedlicher Dichte/ Dacron Du Pont. Kissen aus regenerierten und regenerierbaren Polyesterflocken. Abnehmbarer Bezug aus Stoff.

Sofás monobloque y modulares, pouf y cojín
Estructura de madera. Suspensión sobre cintas elásticas. Asiento, respaldo y base de poliuretano a densidades diferenciadas/ Dacron Du Pont. Cojín de copos de poliéster regenerado y regenerable. Tapizado desfundable de tejido.

1265/212

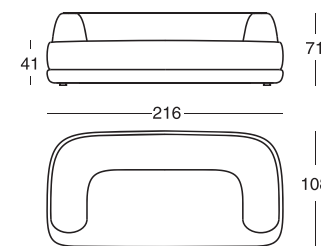

1265/302

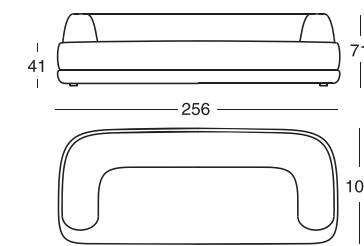

1265/300P

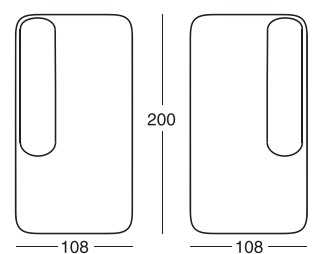

1265/AL1

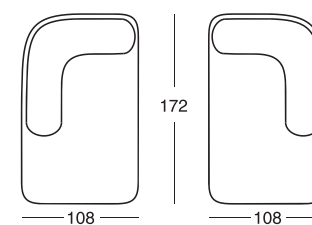

1265/201

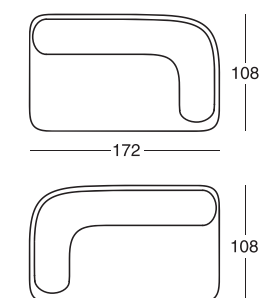

1265/ANG1

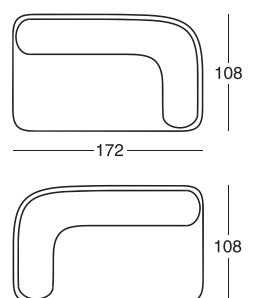

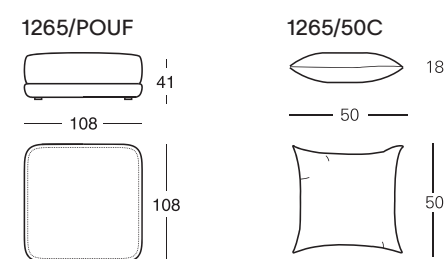
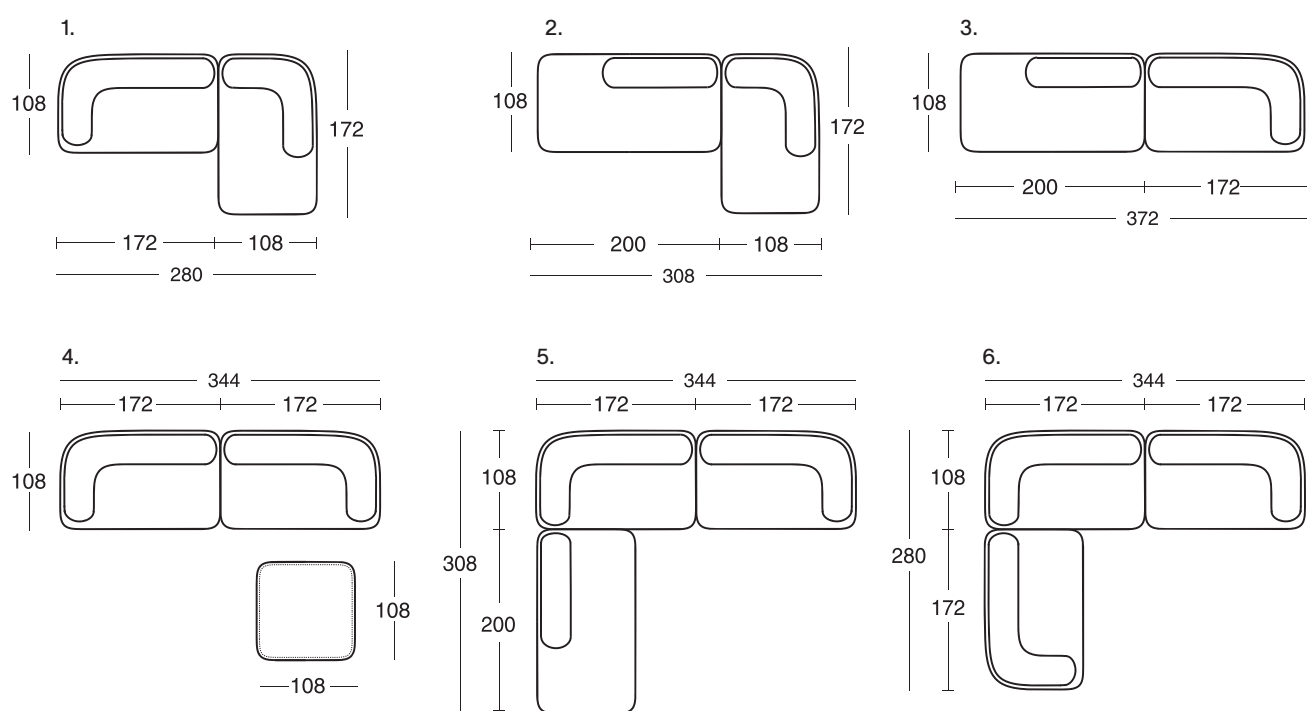

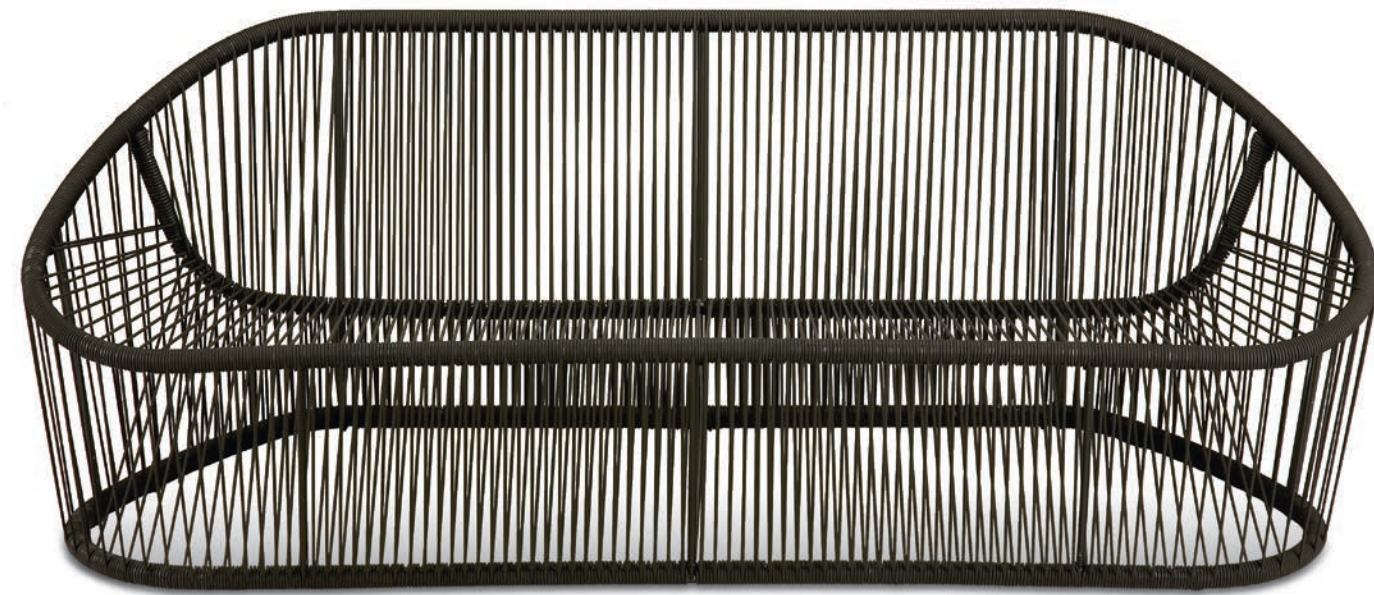

Design

Prospero Rasulo

2008

IN/OUT

Poltrona e divano per esterni e interni
Struttura interna in acciaio verniciato per esterni. Incordatura in filo di PVC con rinforzo interno di nylon colore marrone. A richiesta è disponibile un cuscinetto di seduta imbottito in poliuretano/Dacron Du Pont.

Armchair and sofa for outdoor and indoor
Steel internal structure painted for outdoor use. Weave in brown PVC thread with nylon internal reinforcement. Upon request a small seat cushion upholstered with polyurethane/Dacron Du Pont is available.

Fauteuil et canapé pour extérieurs et intérieurs
Structure interne en acier verni pour extérieurs. Tressage en fil de PVC avec renfort interne en nylon, couleur marron. Sur demande est disponible un coussinet de siège rembourré en polyuréthane/Dacron Du Pont.

Sessel und Sofa für Innen und Freie
Innere Struktur aus lackiertem Stahl fürs Freie. Geflecht aus PVC Draht mit innerer Verstärkung aus Nylon in der Farbe braun. Auf Nachfrage ist ein gepolstertes Sitzkissen mit Polyurethan/Dacron Du Pont verfügbar.

Sillón y sofá para exteriores y interiores
Estructura interior de acero pintado para exteriores. Trenzado en hilo de PVC con refuerzo interno de nylon color marrón. Sobre pedido es disponible un cojín pequeño de asiento acolchado de poliuretano/Dacron Du Pont.

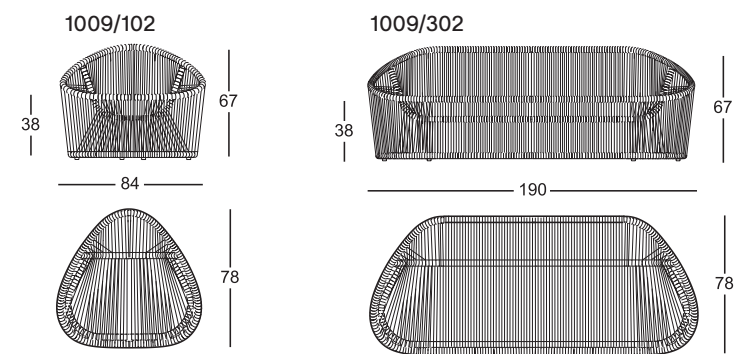



Design

Vincent Van Duysen

2025

Divani monoblocco, componibili e pouf
Struttura in multistrato. Imbottitura bracciolo, schienale e sedile a quote differenziate di poliuretano CIRCULARREFOAM® composto da una percentuale di polioli riciclati/fibra in PET con una percentuale di riciclato post-consumo. Assemblaggio parti privo di collanti. Cuscino schienale in fibra soffiata e tela di PET riciclato. Rivestimento esterno amovibile in stoffa.

Monobloc, modular sofas and pouf
Plywood frame. Armrest, backrest and seat padding in graduated CIRCULARREFOAM® polyurethane comprising a percentage of recycled polyols/PET fibre including a percentage of post-consumer recycled material. Parts assembly without glues. Backrest cushion in blown PET fibre and PET canvas. Removable external cover in fabric.

Canapés monoblocs, composables et pouf
Structure multicouche. Rembourrage des accoudoirs, du dossier et de l'assise en polyuréthane CIRCULARREFOAM® à densités variables, composé d'un pourcentage de polyols recyclés/fibre de PET avec un pourcentage de matériau recyclé post-consommation. Assemblage des pièces sans adhésifs. Coussin de dossier en fibre soufflée et toile de PET recyclé. Revêtement extérieur déhoussable en tissu.

Einteilige, zusammenstellbare Sofas und Hocker
Sperrholzgestell. Polsterung von Armlehnen, Rückenlehnen und Sitzflächen in abgestufter CIRCULARREFOAM®-Polyurethan, bestehend aus einem Prozentsatz recycelter Polyole/PET-Fasern einschließlich eines Prozentsatzes post-consumer Recyclingmaterials. Montage der Teile ohne Klebstoffe. Rückenkissen aus geblasener PET-Faser und PET-Gewebe. Abnehmbarer Außenbezug aus Stoff.

Sofás monobloque, modulares y pouf
Estructura de madera contrachapada. Acolchado de brazos, respaldo y asiento en poliuretano CIRCULARREFOAM® con densidades diferenciadas, compuesto por un porcentaje de poliols reciclados/fibra de PET con un porcentaje de material reciclado postconsumo. Montaje de piezas sin colas. Cojín de respaldo en fibra soplada y lona de PET reciclado. Tapizado exterior desenfundable en tejido.

1338/100

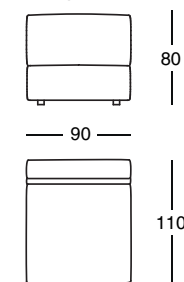

1338/101

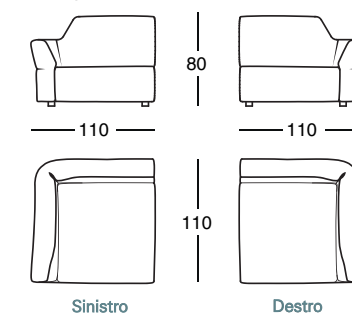

1338/125

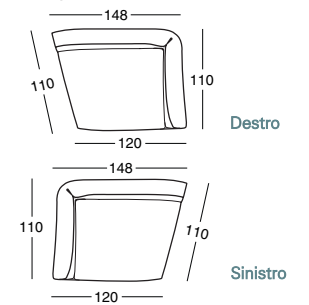

1338/201

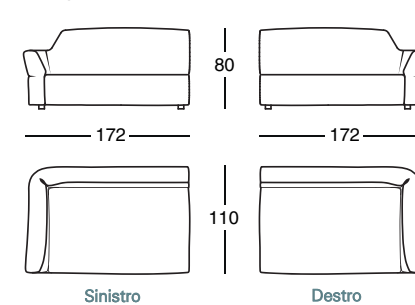

1338/201C

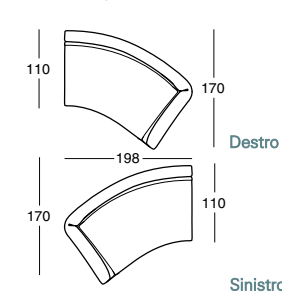

1338/202

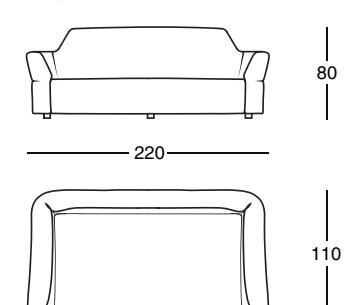



1338/212

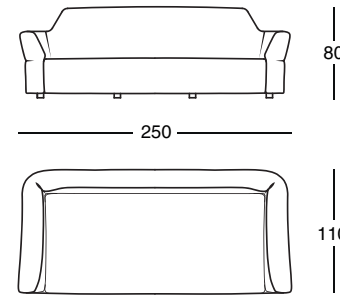

1338/302

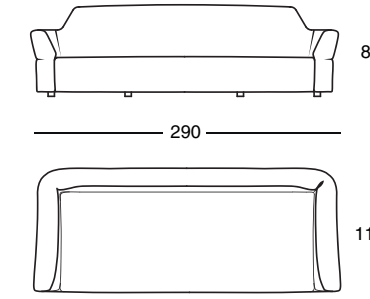

1338/AL1

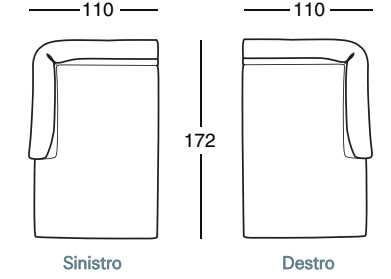

1338/ANG1

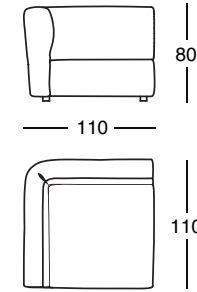

1338/POUF

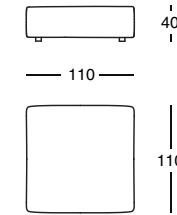

1338/55C

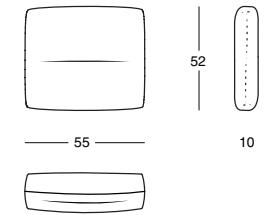

1338/65C

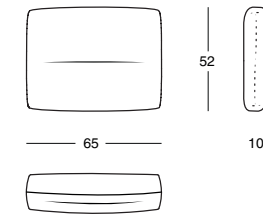

1338/75C

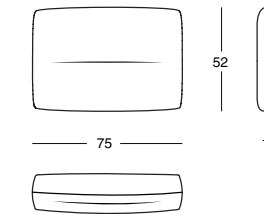

1.

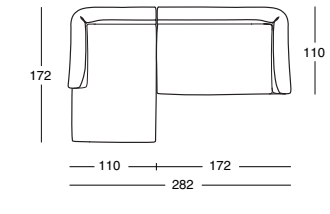

2.

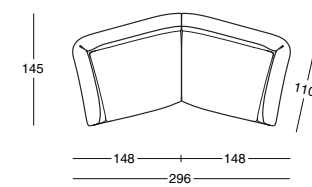

3.

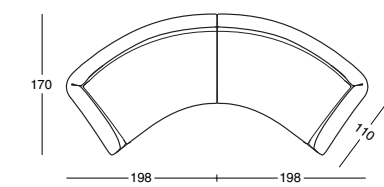

4.

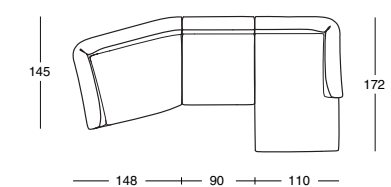

5.

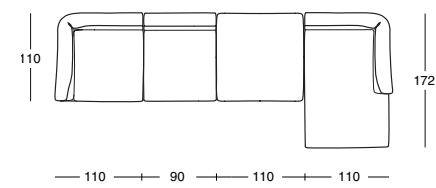

6.

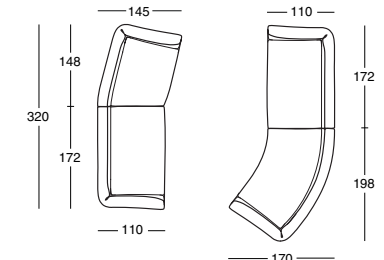

7.

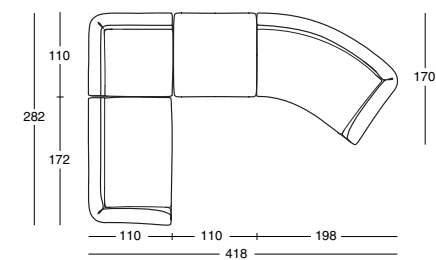

8.

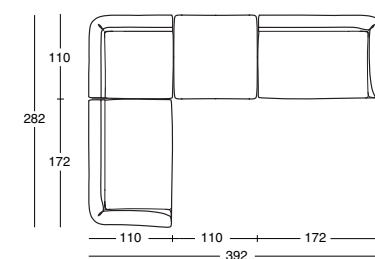

9.

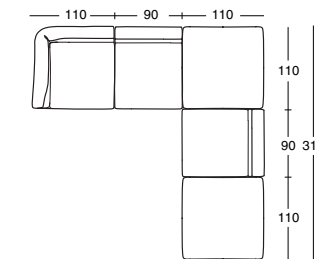

10.

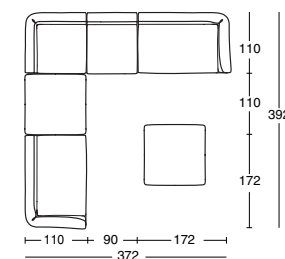

Flamingo 1333



Design

Damian Williamson

2017

Poltrona, divani monoblocco e componibili
Piedini in lega di alluminio lucidato, nichelsatinato colore naturale o nero, oppure verniciato colore nero. Struttura in acciaio. Molleggio su nastri elastici. Imbottitura in poliuretano/fibra poliestere termolegata. Cuscino seduta in poliuretano/fibra poliestere termolegata. Imbottitura cuscini schienale e poggiatesta in piuma d'oca. Rivestimento sfilabile in stoffa o in pelle.

Armchair, monobloc and modular sofas
Polished or black painted aluminum alloy feet, or with natural or black nickel-satin finish. Steel frame. Elastic strips suspension. Upholstery in polyurethane/heat-bound polyester fibre. Seat cushion upholstered with polyurethane/heat-bound polyester fibre. Back and lumbar cushions upholstered with goose feathers. Removable fabric or leather cover.

Fauteuil et canapés monoblocs et composables
Pieds en alliage d'aluminium poli, ou nickel satiné, dans les couleurs naturel ou noir, ou verni noir. Structure en acier. Suspension sur sangles élastiques. Rembourrage en polyuréthane/fibre polyester liée à chaud. Coussins d'assise en polyuréthane/fibre polyester liée à chaud. Rembourrage en plume d'oie. Revêtement déhoussable en tissu ou en cuir.

Sessel, einteilige und zusammenstellbare Sofas
Füße aus polierter oder schwarz-lackierter Aluminiumlegierung, oder mit naturfarben- oder schwarz vernickeltem und mattiertem Finish. Gestell aus Stahl. Federung auf elastischen Gurten. Polsterung aus Polyurethan/wärmegebundener Polyesterfaser. Sitzkissen aus Polyurethan/wärmegebundener Polyesterfaser. Polsterung der Rücken- und Nierenkissen aus Gänsefedern. Abnehmbarer Bezug aus Stoff oder Leder.

Butaca, sofás monobloque y modulares
Patas de aleación de aluminio pulido, o niquelado mate en los acabados natural o negro, o pintado negro. Estructura de acero. Suspensión sobre cintas elásticas. Acolchado de poliuretano/fibra poliéster termounida. Cojín asiento de poliuretano/fibra poliéster termounida. Cojín de respaldo y lumbar acolchados con pluma de ganso. Tapizado desenfundable de tejido o de piel.

Piedini/Feet/Pieds/Füße/Patas





1333/301

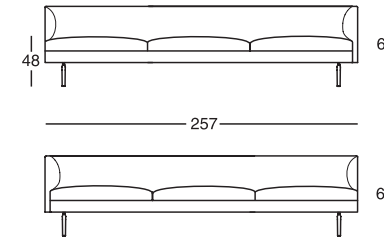

1333/AL1

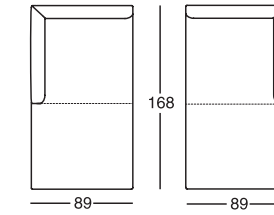

1333/58C

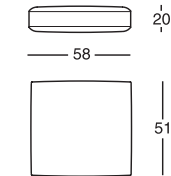

1333/74C

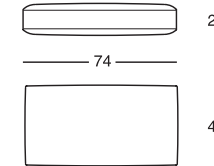

1333/54C

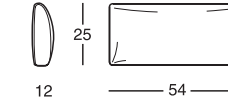

1.

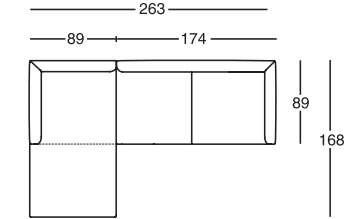

2.

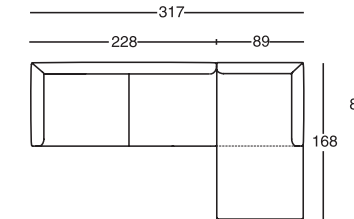

3.

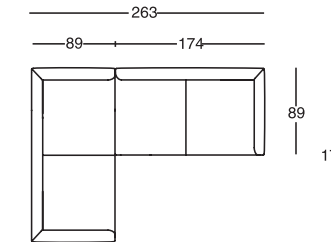

4.

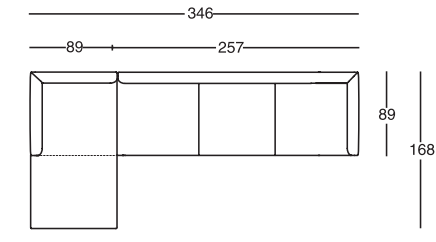

5.

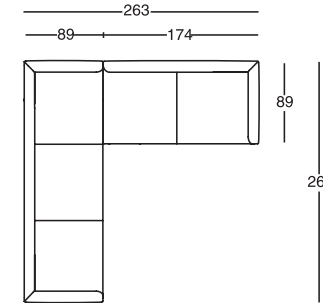

6.

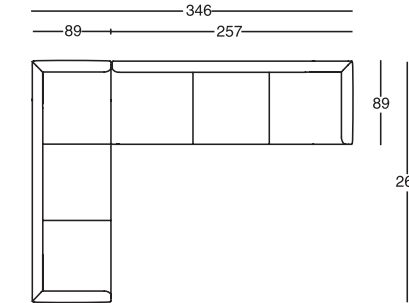

7.

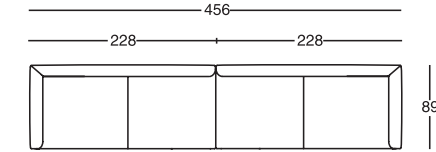

8.

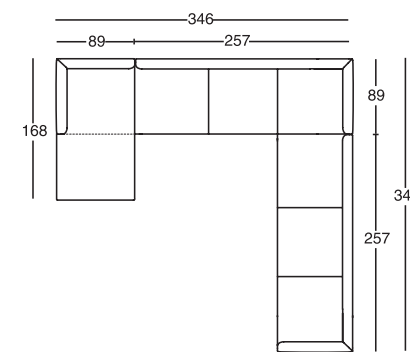

9.

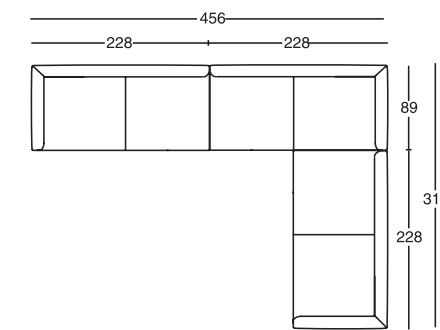

10.

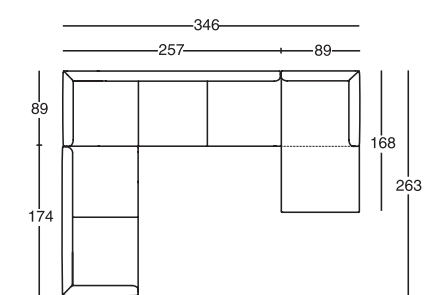

1333/102

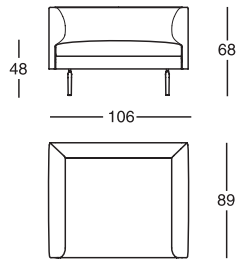

1333/202

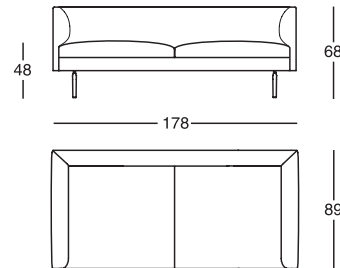

1333/212

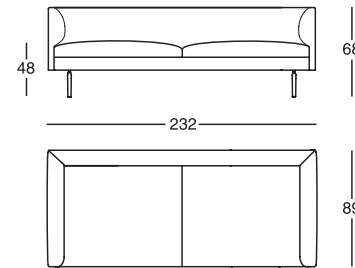

1333/302

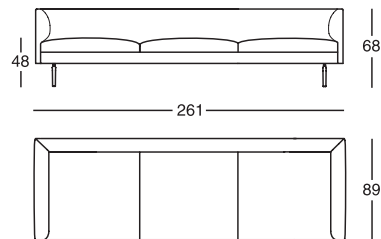

1333/201

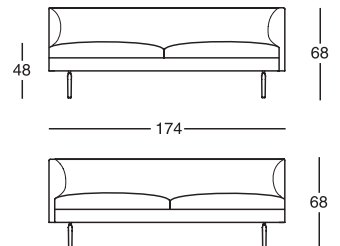

1333/211

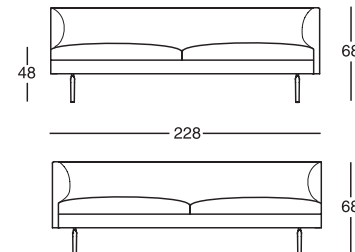

Kilt ¹²⁴²

Kilt 84 ¹²⁴³



Design

Emaf Progetti

2006

Poltrona, divani monoblocco, componibili, pouf
Struttura in acciaio. Molleggio su nastri elastici. Imbottitura in poliuretano/ fibra poliestere termolegata. Rivestimento con cuscino seduta trapuntato, sfilabile, in stoffa o in pelle.

Armchair, monobloc, modular sofas, pouf
Steel frame. Elastic strips suspension. Upholstery in polyurethane/heat-bound polyester fibre. Removable fabric or leather cover with quilted seat cushion.

Fauteuil, canapés monoblocs, composables, pouf
Structure en acier. Suspensions sur sangles élastiques. Rembourrage en polyuréthane/fibre polyester liée à chaud. Revêtement avec coussin assise surpiqué, déhoussable en tissu ou en cuir.

Sessel, einteilige, zusammenstellbare Sofas, Hocker
Stahlgestell. Federung mit elastischen Gurten. Polsterung aus Polyurethan/wärmegebundener Polyesterfaser. Abnehmbarer Bezug mit Steppung über den Sitzpolstern aus Stoff oder Leder.

Butaca, sofás monobloque, modulares, puf
Estructura de acero. Asiento sobre cintas elásticas. Acolchado de poliuretano/ fibra poliéster termounida. Tapizado con cojín del asiento pespunteado, desenfundable, de tejido o de piel.

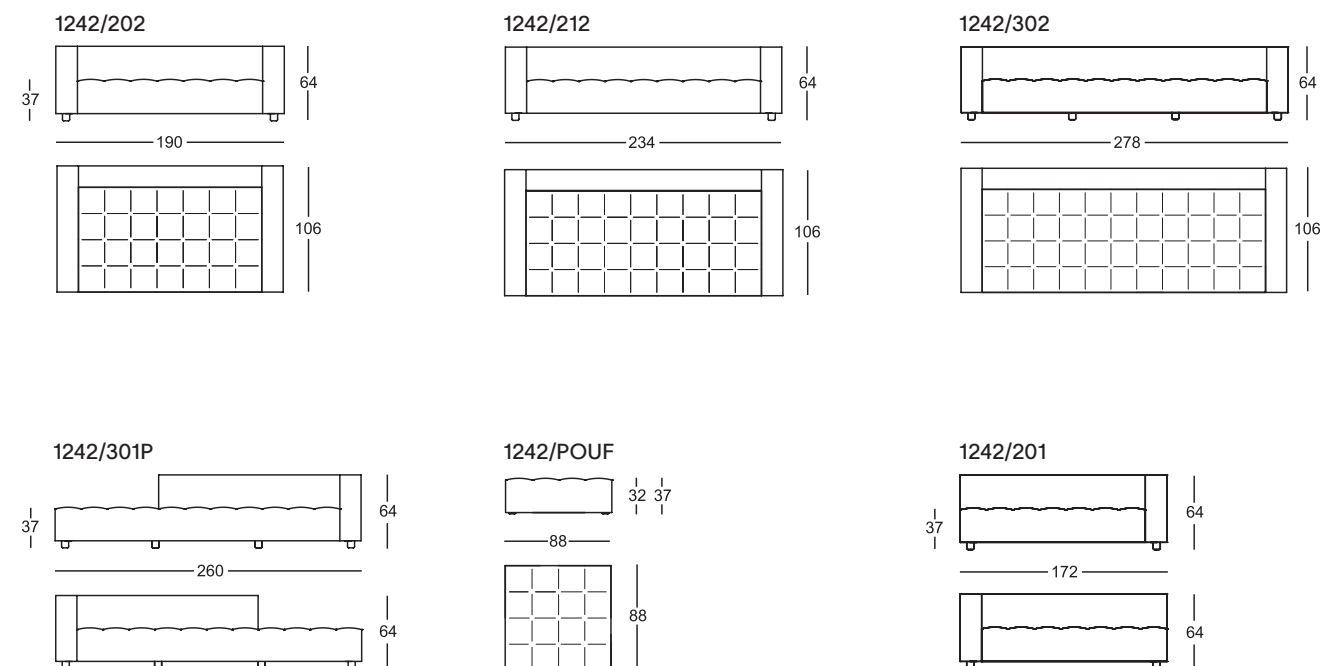

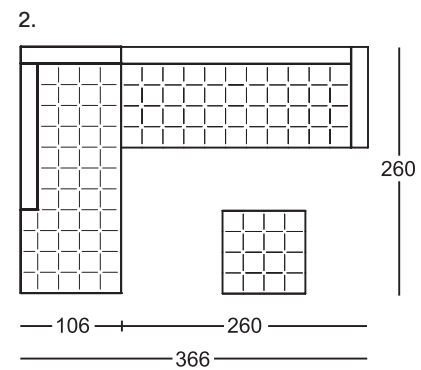
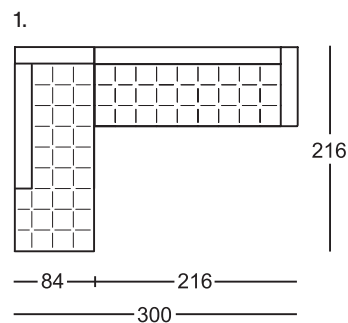
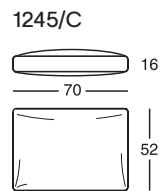
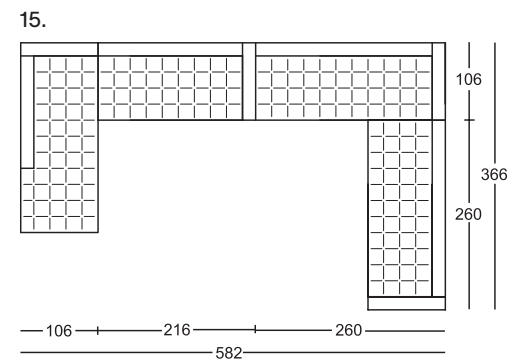
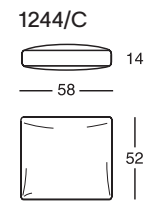
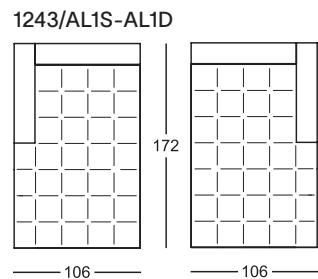
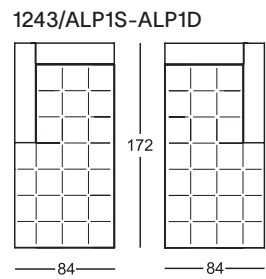
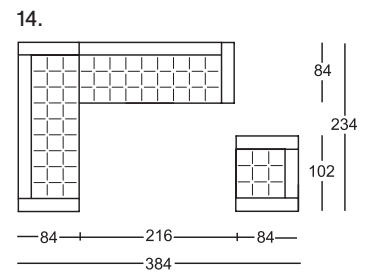
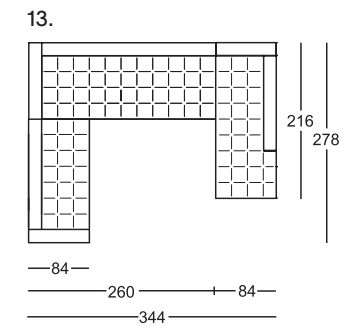
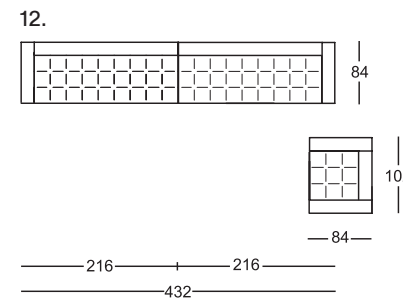
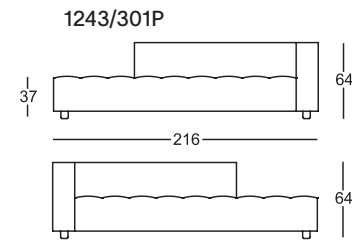
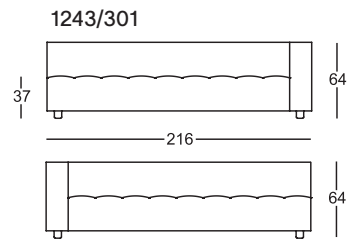
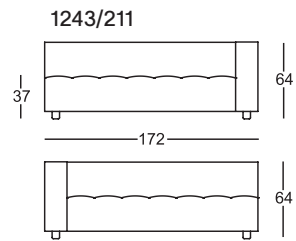
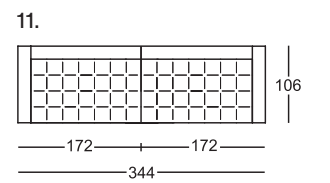
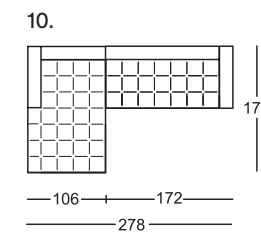
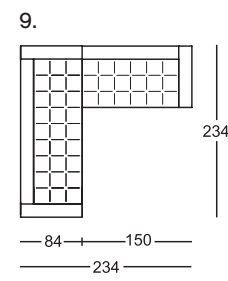
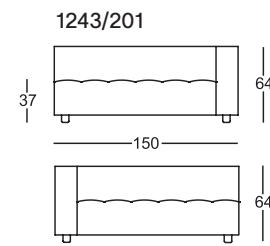
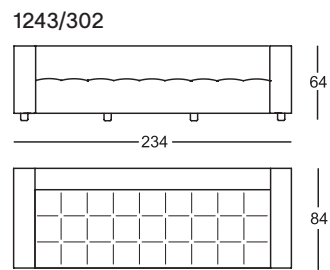
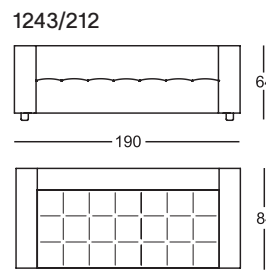
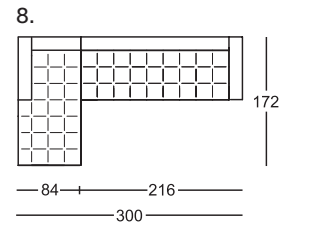
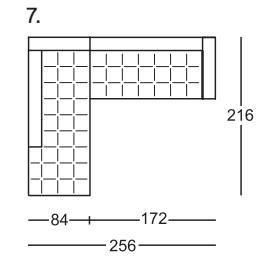
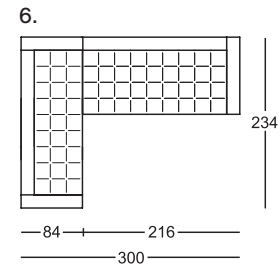
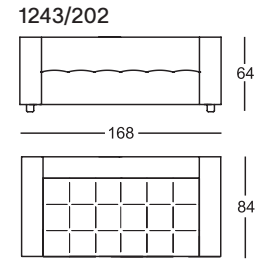
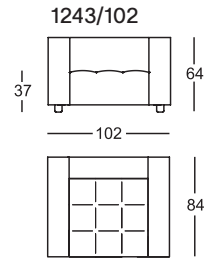
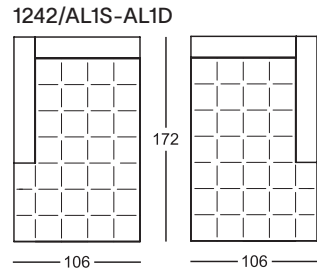
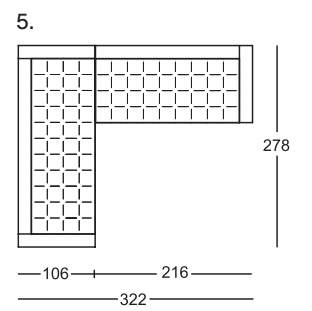
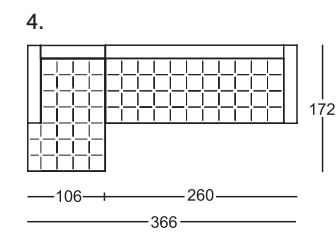
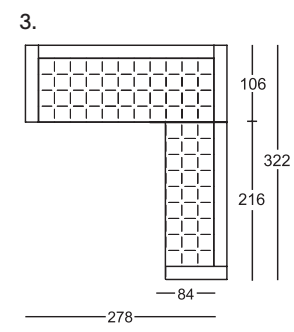
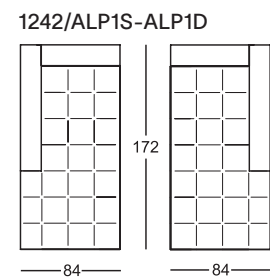
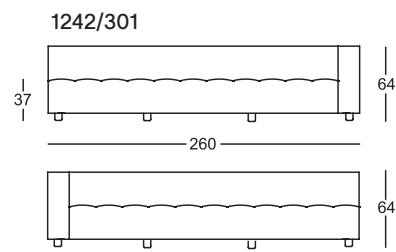
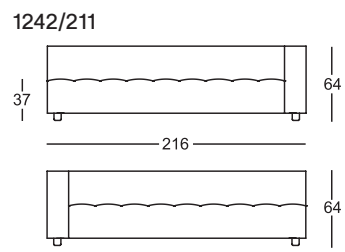



Design

De Pas, D'Urbino, Lomazzi

1982-2019

Divani monoblocco, componibili e pouf
Piedini in lega di alluminio nichel-satinato colore naturale o nero. Struttura in acciaio. Molleggio su nastri elastici. Cuscino seduta unico in poliuretano/fibra poliestere termolegata; cuscini schienale e braccioli in fibra poliestere. Rivestimento sfilabile in stoffa o in pelle.

Monobloc, modular sofas and pouf
Aluminum alloy feet, with natural or black nickel-satin finish. Steel frame. Elastic strips suspension. Single seat cushion in polyurethane/heat-bound polyester fibre; backrest cushions and armrests in polyester fibre. Removable fabric or leather cover.

Canapés monoblocs, composables et pouf
Pieds en alliage d'aluminium nickel satiné dans les finitions naturelle ou noire. Structure en acier. Suspension sur sangles élastiques. Coussin siège d'une seule pièce en polyuréthane/fibre de polyester liée à chaud; coussins dossier et accoudoirs fibre de polyester. Revêtement déhoussable en tissu ou en cuir.

Einteilige, zusammenstellbare Sofas und Hocker
Füße aus Alu-Legierung, mit naturfarben- oder schwarz- vernickeltem und mattiertem Finish. Gestell aus Stahl. Federung mit elastischen Gurten. Einteilige Sitzpolsterung aus Polyurethan/wärmegebundener Polyesterfaser; Rückenissen und Armlehnen aus Polyesterfaser. Abnehmbarer Bezug aus Stoff oder Leder.

Sofás monobloque, modulares y puf
Patas de aleación de aluminio niquelado mate en los acabados natural o negro. Estructura de acero. Asiento sobre cintas elásticas. Cojín de asiento único de poliuretano/fibra poliéster termounida; cojines de respaldo y apoyabrazos de fibra de poliéster. Tapizado desenfundable de tejido o de piel.

Piedini/Feet/Pieds/Füße/Patas

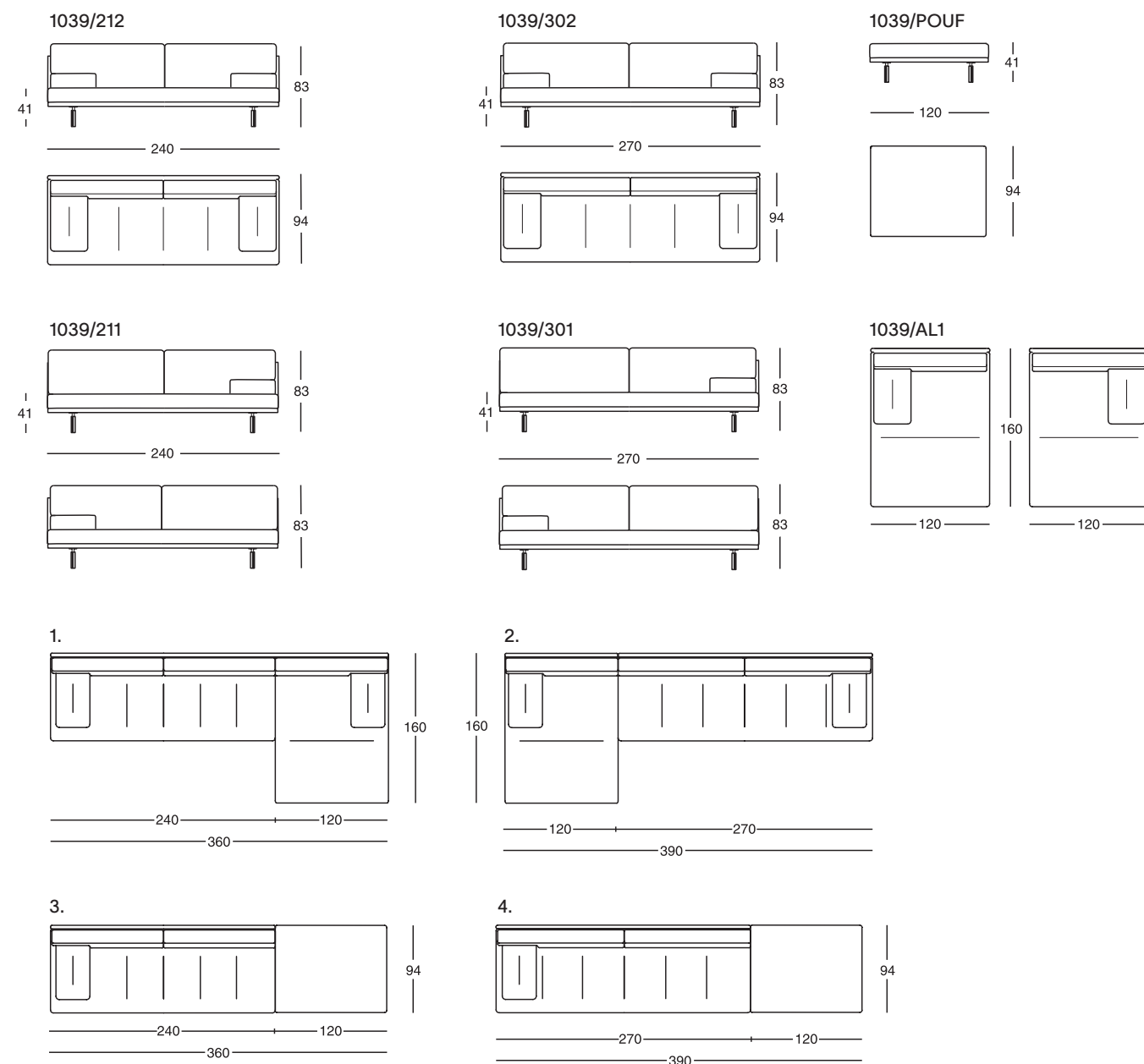



Design

Damian Williamson

2022

Divani monoblocco, componibili rettilinei e curvi con bracciolo o vassoio, pouf
Piedini in acciaio nichelsatinato nero opaco oppure verniciato colore grafite. Struttura in acciaio. Molleggio su nastri elastici. Cuscino seduta unico in poliuretano/fiocchi di poliestere rigenerato e rigenerabile. Cuscino schienale in piuma d'oca – materiale 100% vergine. Cuscino bracciolo in fiocchi di poliestere rigenerato e rigenerabile. Gli elementi terminali rettilinei e curvi possono essere dotati di cuscino bracciolo oppure essere attrezzati con un

vassoio in legno massello di frassino verniciato nero poro aperto opaco sulla base portante del divano. Rivestimento sfilabile in stoffa o in pelle. È disponibile un vassoio circolare Ø 45 cm in legno massello di frassino verniciato nero poro aperto opaco che può essere appoggiato liberamente sui cuscini di seduta. I pannelli perimetrali sono rivestiti nella stessa stoffa o pelle dei cuscini.

Monobloc, straight and curved modular sofas with armrest or tray, pouf
Steel feet, with matt black nickelsatin finish or varnished graphite. Elastic strips suspension. Single-piece seat cushion in polyurethane/regenerated and regenerable polyester flakes. Back cushion in 100% new goose feathers. Armrest cushion in regenerated and regenerable polyester flakes. The straight and curved end-sofas can be equipped with an armrest cushion or with a tray, made of solid matt black painted ash with open pore, placed on the supporting base of the sofa. Removable

fabric or leather cover. One round-shaped tray, diameter 45 cm, made of solid matt black painted ash with open pore, is available and can be placed as desired on the seat cushions. The side panels are covered in the same fabric or leather as the cushions.

Canapés monoblocs, composables rectilignes et incurvés avec accoudoir ou plateau, pouf
Pieds en acier nickelsatiné noir mat ou verni graphite. Structure en acier. Suspension sur sangles élastiques. Coussin assise dans une seule pièce en polyuréthane à densité variable/flocons de polyester régénérés et régénérables. Coussin dossier en plume d'oie - matériel 100% vierge. Coussin accoudoir en flocons de polyester régénérés et régénérables. Les éléments terminaux droits et courbes peuvent être équipés d'un coussin d'accoudoir ou être équipés

d'un plateau en bois de frêne massif verni noir mat à pores ouverts sur la base de support du canapé. Revêtement déhoussable en tissu ou en cuir. Un plateau circulaire Ø 45 cm est disponible en bois de frêne massif verni noir mat à pores ouverts qui peut être placé librement sur les coussins d'assise. Les panneaux périmétriques sont recouverts du même tissu ou du même cuir que les coussins.

Einteilige, zusammenstellbare geradlinige oder gebogene Sofas mit Armlehne oder Tablett, Hocker
Stahl-Füße, in der schwarz vernickelten und mattierten Ausführung oder Graphit lackiert. Stahl-Gestell. Federung mit elastischen Gurten. Einteiliges Sitzkissen aus Polyurethan mit unterschiedlicher Dichte/regenerierten und regenerierbaren Polyesterflocken. Rückenkissen aus 100% reinen Gänsefedern. Armlehnen Kissen aus regenerierten und regenerierbaren Polyesterflocken. Die geradlinigen und gebogenen

einem Armlehnen Kissen oder einem Tablett, aus massivem Eschenholz, matt offenporig schwarz lackiert, auf dem Traggestell des Sofas ausgestattet werden. Abnehmbarer Bezug aus Stoff oder Leder. Ein rundes Tablett, Durchmesser 45 cm., aus massivem Eschenholz, matt offenporig schwarz lackiert, ist lieferbar und kann wunschgemäß auf dem Sitzkissen gelegt werden. Die Seitenpaneele werden mit dem gleichen Stoff oder Leder wie die Kissen bezogen.

Sofás monobloque, modulares rectilíneos y curvos con apoyabrazos o bandeja, puf
Patas de acero niquelado mate negro o pintado color grafito. Estructura de acero. Suspensión sobre cintas elásticas. Cojín de asiento único de poliuretano a densidades diferenciadas/ copos de poliéster regenerado y regenerable. Cojín de respaldo de pluma de ganso – material 100% virgen. Cojín apoyabrazo de copos de poliéster regenerado y regenerable. Los elementos terminales rectilíneos y curvos pueden equiparse con un cojín apoyabrazos o equiparse con una bandeja en madera maciza de

fresno pintada de negro poro abierto mate colocada en la estructura del sofá. Tapizado desenfundable de tejido o de piel. Una bandeja redonda de Ø 45 cm está disponible en madera maciza de fresno pintada mate de poro abierto negro que se puede colocar libremente sobre los cojines de asiento. Los paneles perimetrales están tapizados en el mismo tejido o piel de los cojines.

Piedini/Fee/Pieds/Füße/Patas



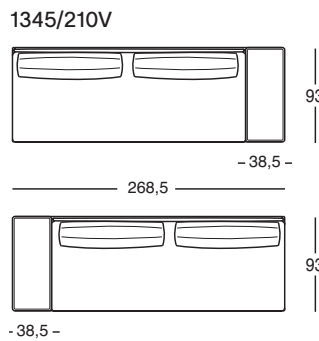
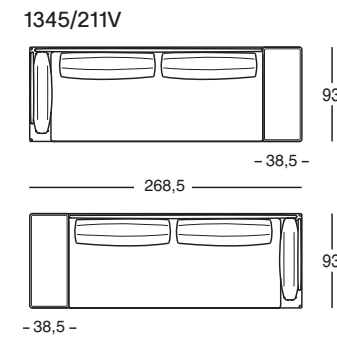
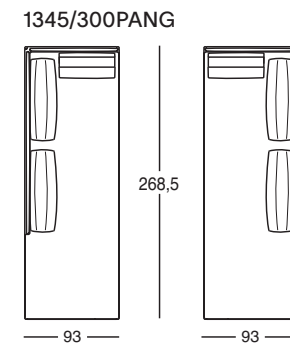
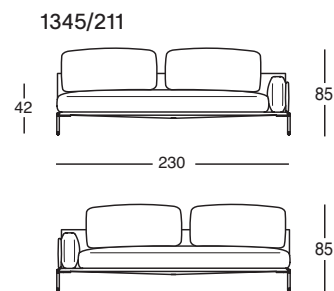
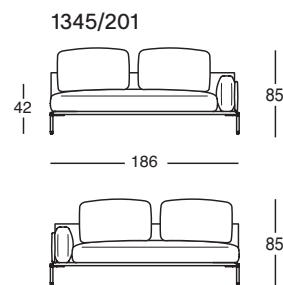
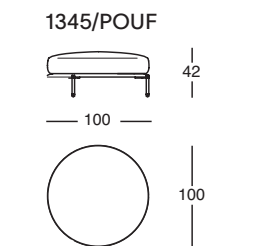
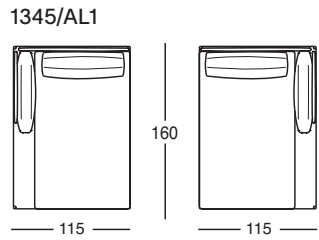
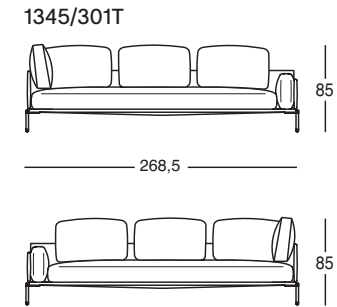
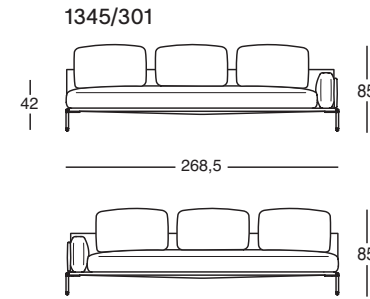
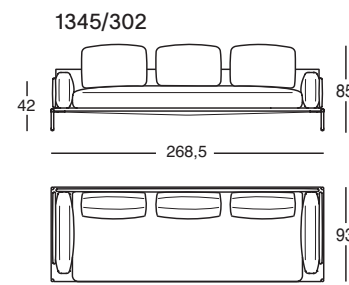
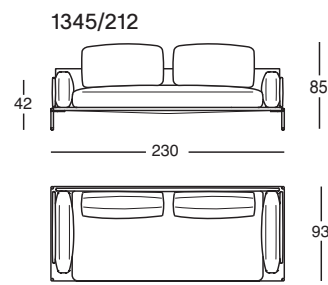
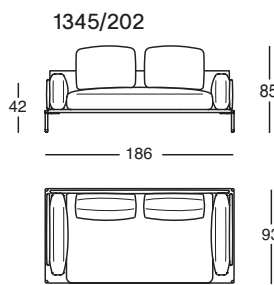

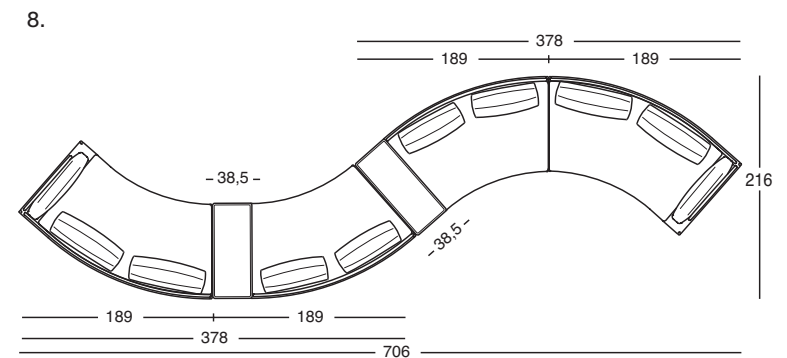
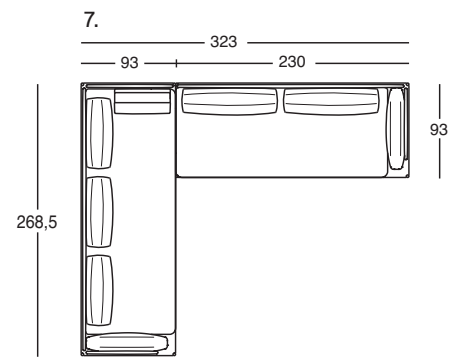
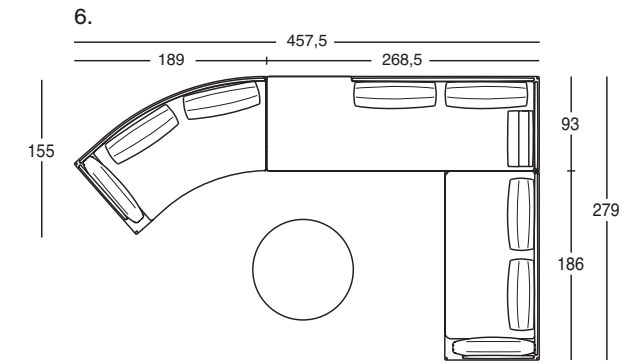
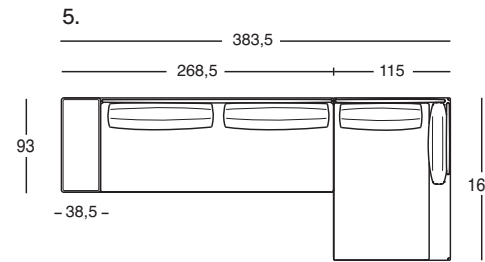
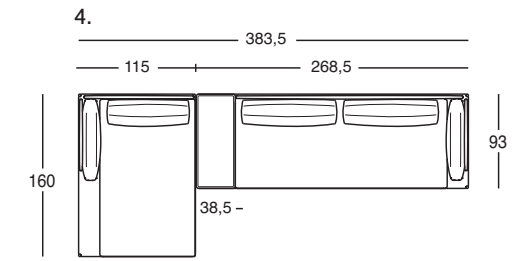
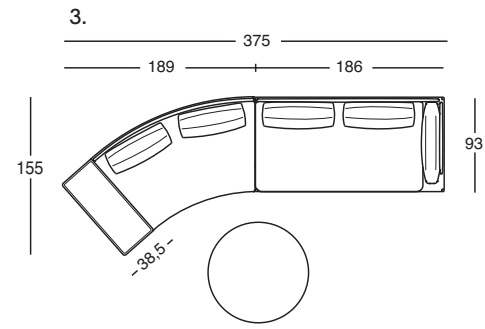

1345/201C

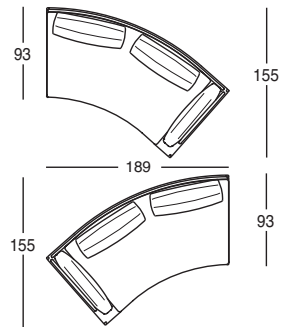

1345/200CV

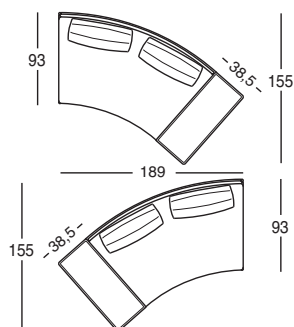

1345/VD45

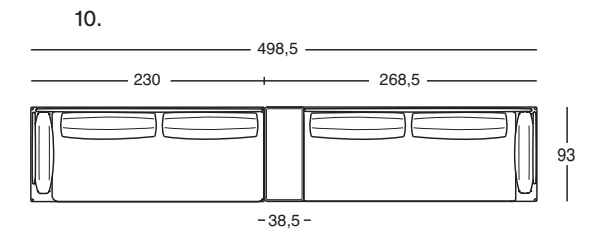
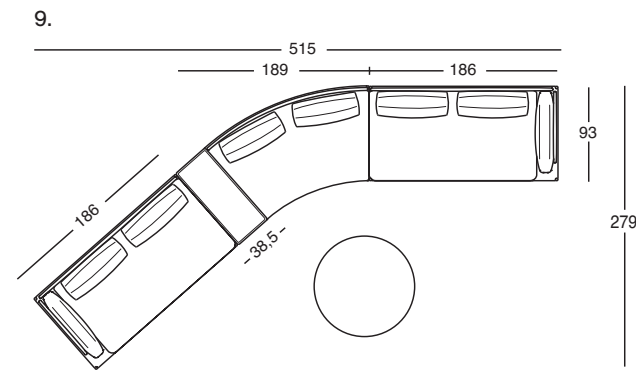
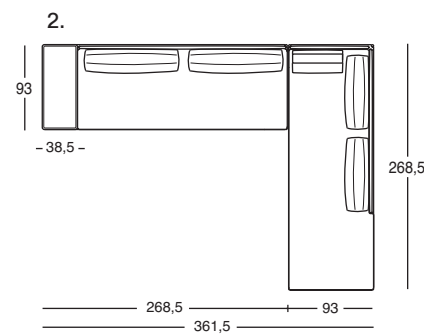
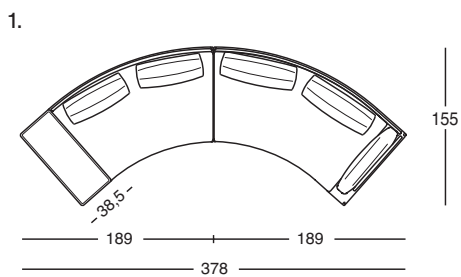
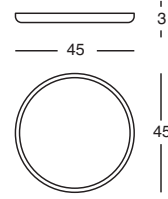



Design

Emaf Progetti

2011

IN/OUT

Divani monoblocco e pouf per esterni
Struttura portante in acciaio verniciato per esterni, colore talco o nero. Molleggio su nastri elastici. Cuscini seduta, schienale e bracciolo in poliuretano reticolato a cellula aperta/Paineira, fibra vegetale idrorepellente. Rivestimento sfilabile in tessuto Talasso.

Monobloc sofas and pouf for outdoor use
Supporting frame in painted steel for outdoor use in the shade of talc or black. Elastic strips suspension. Seat, back and armrest cushion in open cell reticulated polyether/Paineira, water-repellent vegetal fibre. Removable cover in fabric Talasso.

Canapés monoblocs et pouf pour extérieur
Structure portante en acier verni pour extérieurs, couleur talc ou noir. Suspension sur sangles élastiques. Coussins d'assise, dossier et accoudoir en polyéther réticulé à cellule ouverte/Paineira, fibre végétale hydrofuge. Revêtement déhoussable en tissu Talasso.

Einteilige Sofas und Hocker fürs Freie
Tragendes Gestell mit Lackierung fürs Freie, in den Farben Talkum oder schwarz. Federung auf elastischen Gurten. Sitzkissen, Rücken und Armlehne aus vernetztem Polyether mit offenen Zellen/Paineira, Pflanzenfaser, wasserabweisend. Abnehmbarer Bezug aus Stoff Talasso.

Sofás monobloque y puf para exteriores
Estructura portante de acero barnizada para exteriores color talco o negro. Suspensión sobre cintas elásticas. Cojines de asiento, respaldo y apoyabrazo de poliéter reticulado con célula abierta/Paineira, fibra vegetal hidrórepelente. Tapizado desenfundable de tejido Talasso.

Struttura/Frame/Structure/Gestell/Estructura



1034/202

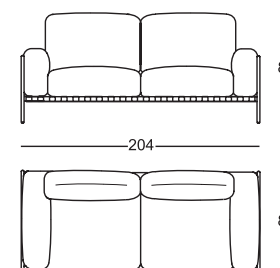

1034/212

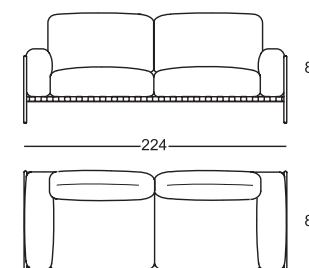

1034/302

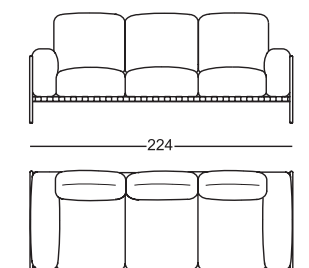

1034/312

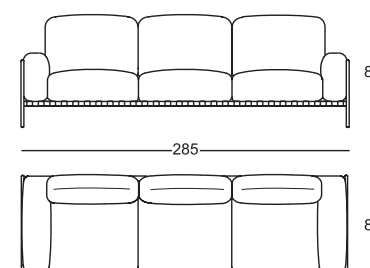

1034/402

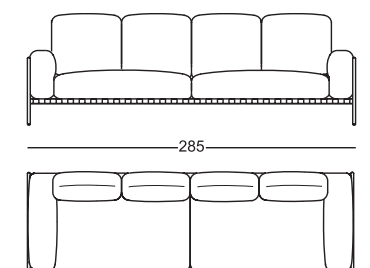

1034/POUF

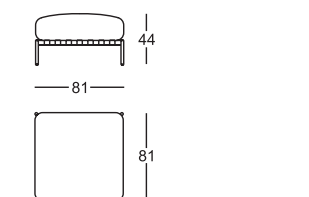

Pianoalto+ 1274

Pianoalto+ 96 1275

NEW ELEMENTS



Design

Palomba Serafini Associati

2012 - 2026

Divani monoblocco, componibili e pouf
Piedini in acciaio verniciati colore grafite. Struttura in legno. Molleggio su nastri elastici.
Imbottitura sedile e schienale a quote differenziate di poliuretano CIRCULARREFOAM® composto da una percentuale di polioli riciclati/fibra in PET con una percentuale di riciclato post-consumo. Cuscino schienale in fibra soffiata e tela di PET riciclato. Rivestimento esterno sfilabile in stoffa o in pelle.

Monobloc and modular sofas and pouf
Graphite painted steel feet. Wooden frame. Elastic strips suspension.
Seat and backrest padding in graduated CIRCULARREFOAM® polyurethane comprising a percentage of recycled polyols/PET fibre including a percentage of post-consumer recycled material. Backrest cushion in blown PET fibre and PET canvas. Removable external cover in fabric or leather.

Canapés monoblocs, composables et pouf
Pieds en acier verni graphite. Structure en bois. Suspension sur sangles élastiques.
Rembourrage de l'assise et du dossier en polyuréthane CIRCULARREFOAM® à densités variables, composé d'un pourcentage de polyols recyclés/fibre de PET avec un pourcentage de matériau recyclé post-consommation. Coussin de dossier en fibre soufflée et toile de PET recyclé. Revêtement extérieur déhoussable en tissu ou en cuir.

Einteilige, zusammenstellbare Sofas und Hocker
Füße aus graphitfarben lackiertem Stahl. Gestell aus Holz. Federung auf elastischen Gurten.
Polsterung von Sitzflächen und Rückenlehnen aus abgestuftem CIRCULARREFOAM®-Polyurethan, das einen Anteil an recycelten Polyolen/PET-Fasern einschließlich eines Anteils an Post-Consumer-Recyclingmaterial enthält. Rückenkissen aus geblasener PET-Faser und PET-Gewebe. Abnehmbarer Außenbezug aus Stoff oder Leder.

Sofás monobloques, modulares y pouf
Pies de acero lacados en grafito. Estructura de madera. Suspensión con cintas elásticas.
Asiento y respaldo acolchados con densidades diferenciadas de poliuretano CIRCULARREFOAM®, compuesto por un porcentaje de poliols reciclados/fibra de PET con un porcentaje de material reciclado postconsumo. Cojín de respaldo en fibra soplada y lona de PET reciclado. Tapizado exterior desenfundable en tejido o piel.

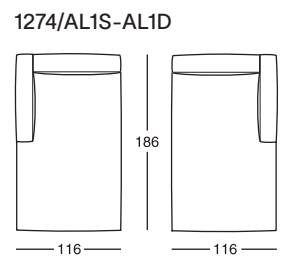
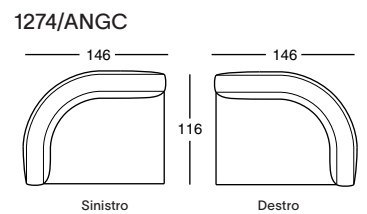
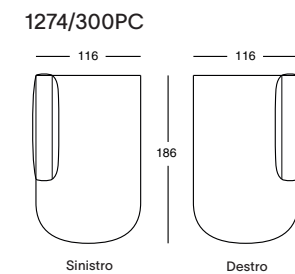
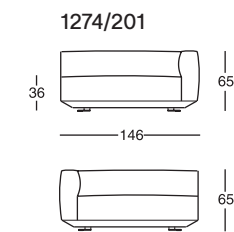
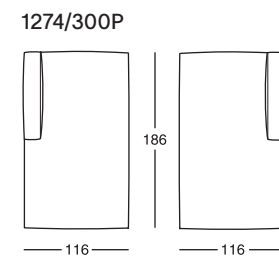
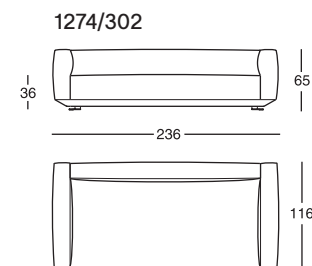



1274/55C

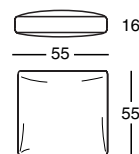

1274/70C

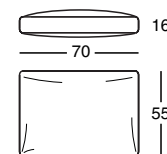

1275/212

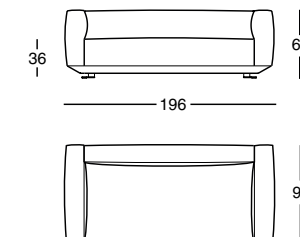

1275/302

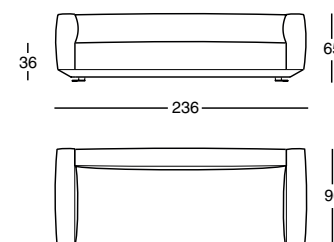

1275/201

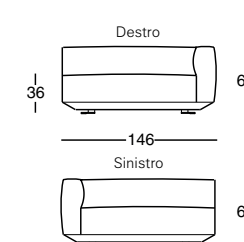

1275/301

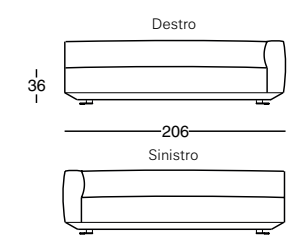

1275/300P

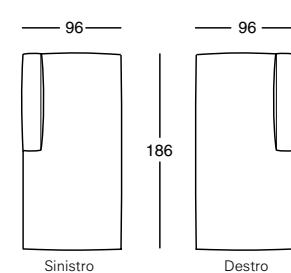

1275/AL1S-AL1D

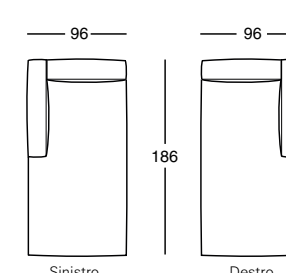

1275/200

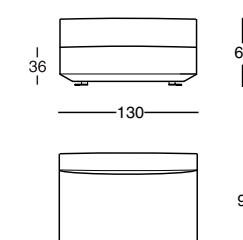

1274/POUF

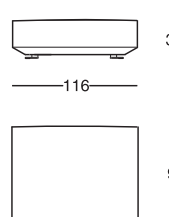

1275/55C

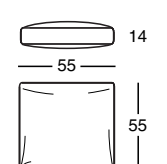

1275/70C

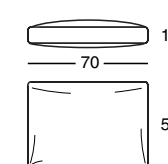

1274/301 - 1274/301C

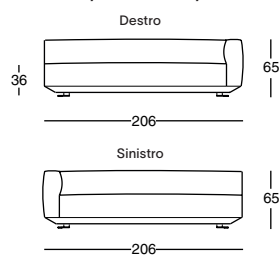

1274/200

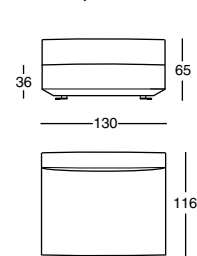

1274/AL1C

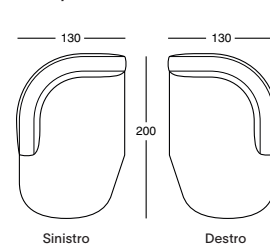

1274/245

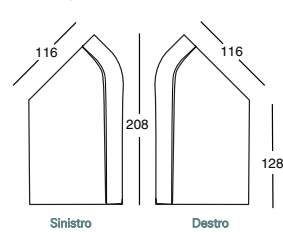

1274/245P

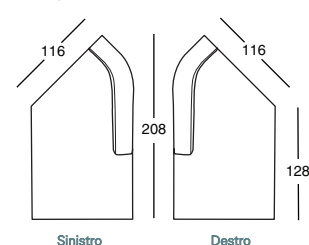

1274/POUF

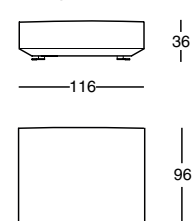

1.

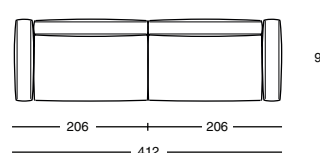

2.

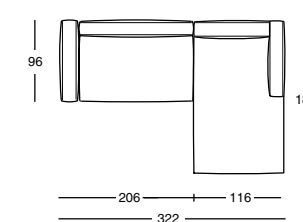

3.

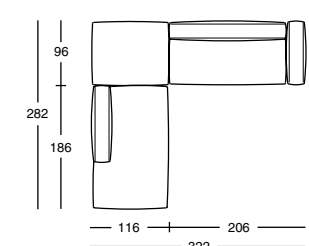

4.

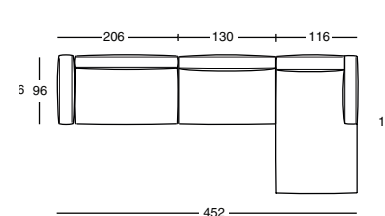

5.

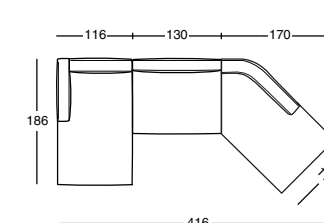

6.

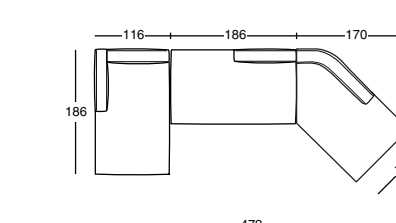

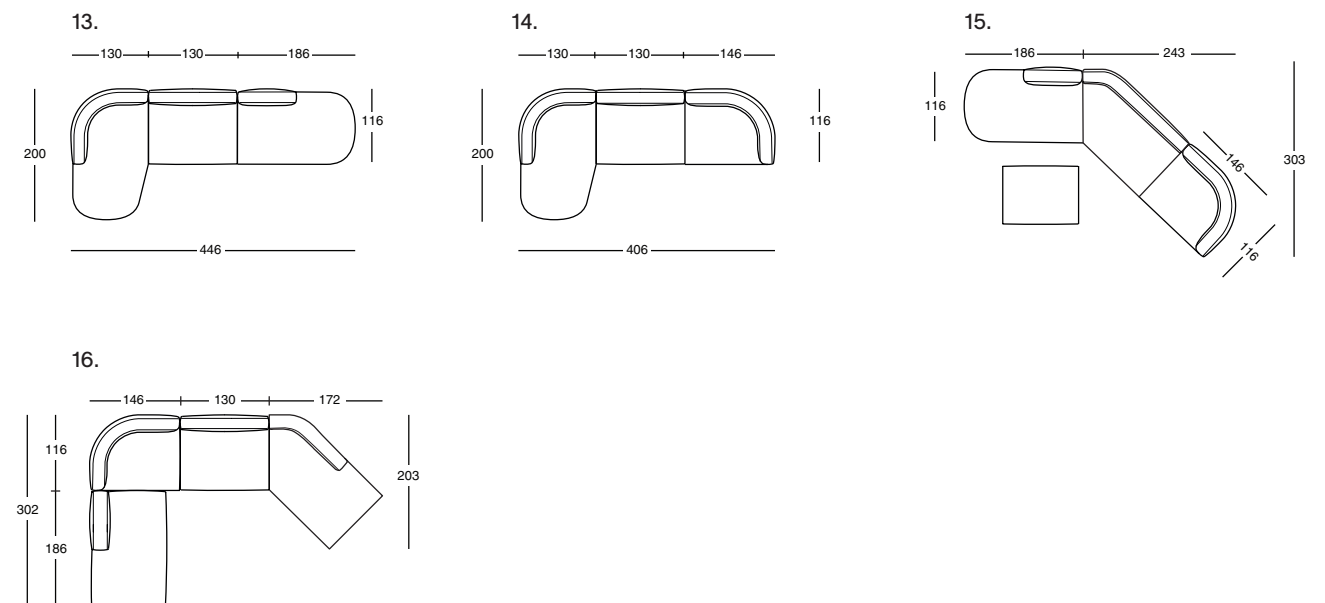
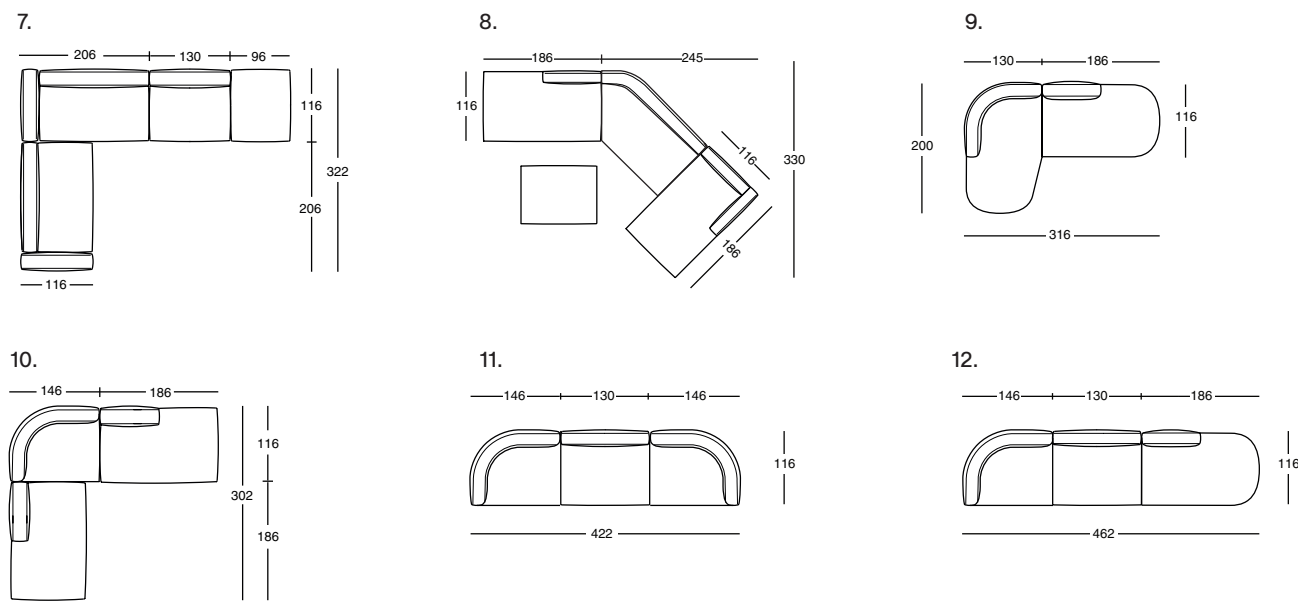



Design

Damian Williamson

2019

Divani monoblocco e componibili.

Base in legno rivestita nello stesso tessuto o pelle del divano. Struttura in legno. Molleggio su nastri elastici. Imbottitura schienale e sedile in poliuretano/fibra poliestere termolegata. Cuscino schienale in piuma d'oca - materiale 100% vergine. Cuscino a rullo in poliuretano/fibra

poliestere termolegata. Rivestimento con cuscino seduta trapuntato, sfilabile in stoffa o in pelle. A richiesta, per i divani monoblocco, è disponibile la versione con tutti gli schienali alti.

Monobloc and modular sofas
Wooden base covered with the same fabric or leather of the sofa. Wooden frame. Elastic strips suspension. Backrest and seat upholstered with polyurethane/heat-bound polyester fibre. Backrest cushion in 100% new goose feathers. Roll-shaped cushion in polyurethane/

heat-bound polyester fibre. Removable fabric or leather cover with quilted seat cushion. Upon request, only for the monobloc sofas, the version with all higher backrests is available.

Canapés monoblocs et composables
Embase en bois revêtu dans le même tissu ou cuir du canapé. Structure en bois. Suspension sur sangles élastiques. Rembourrage du dossier et du siège en polyuréthane /fibre de polyester liée à chaud. Coussin dossier en plume d'oie - matériel 100% vierge. Coussin cale-reins en

polyuréthane/fibre polyester liée à chaud. Revêtement avec coussin siège surpiqué, déhoussable en tissu ou en cuir. Sur demande, pour les canapés monoblocs, il est disponible une version avec tous les dossiers hauts.

Einteilige und zusammenstellbare Sofas
Holzsockel mit dem gleichen Stoff oder Leder Bezug des Sofas. Holzgestell. Federung mit elastischen Gurten. Polsterung der Rückenlehne und Sitz aus Polyurethan/wärmegebundener Polyesterfaser. Rückenkissen mit 100% reinen Gänsefedern. Nierenrolle-Kissen

aus Polyurethan/wärmegebundener Polyesterfaser. Abnehmbarer Bezug mit Steppung über den Sitzpolstern aus Stoff oder Leder. Auf Nachfrage, nur für die einteilige Sofas, ist die Ausführung mit allen höhen Rückenlehnen verfügbar.

Sofás monobloque y modulares
Base en madera tapizada con el mismo tejido o piel del sofá. Estructura en madera. Suspensión sobre cintas elásticas. Acolchado del respaldo y del asiento en poliuretano/fibra poliéster termounida. Cojín de respaldo en pluma de ganso, material 100% virgen. Cojín lumbar en poliuretano/

fibra poliéster termounida. Tapizado con cojín de asiento respuntheado, desenfundable de tejido o de piel. Sobre pedido, para los sofás monobloque, está disponible la versión con los respaldos altos.

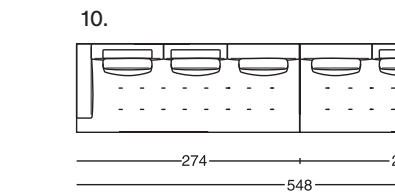
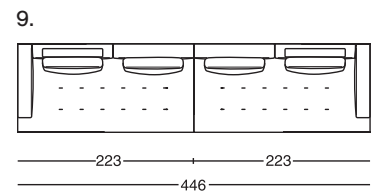
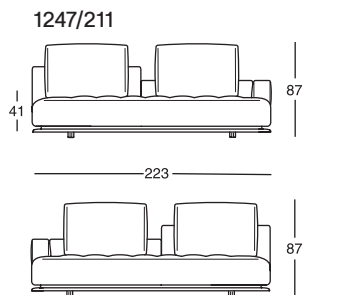
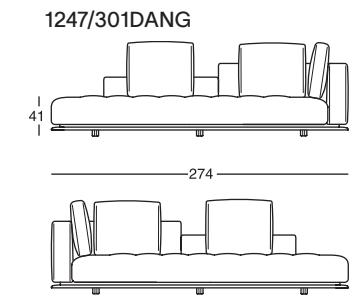
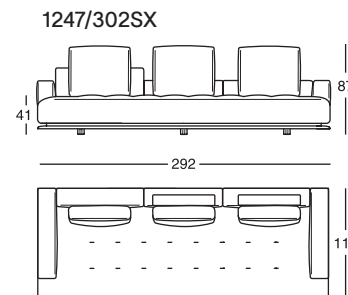
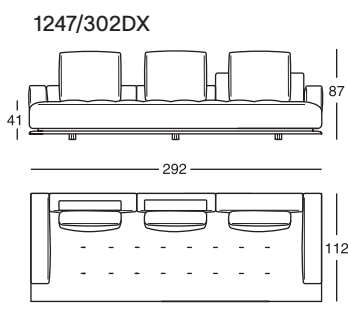
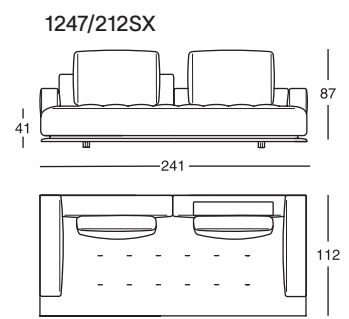
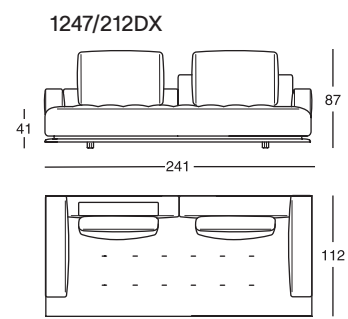
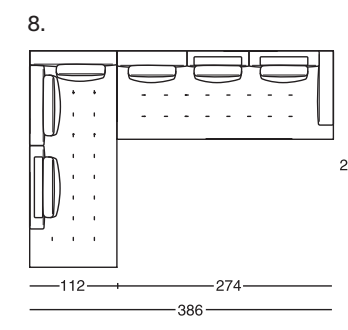
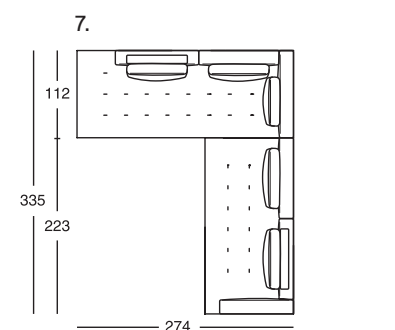
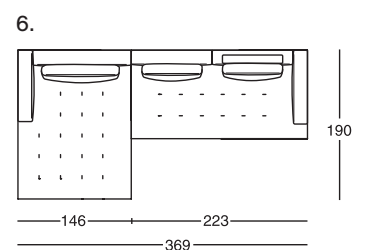
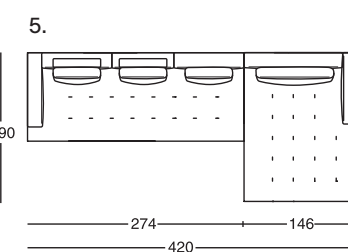
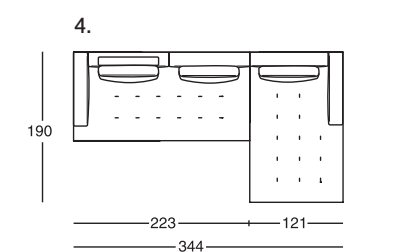
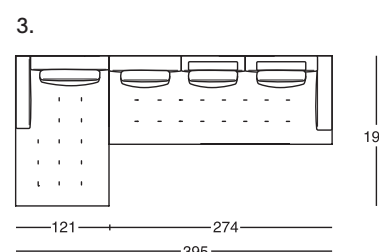
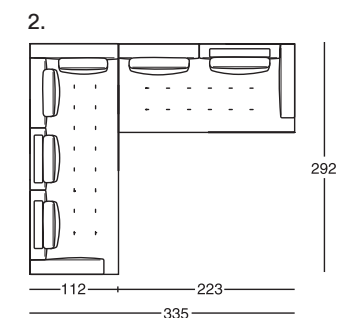
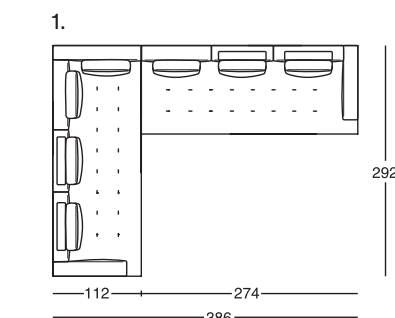
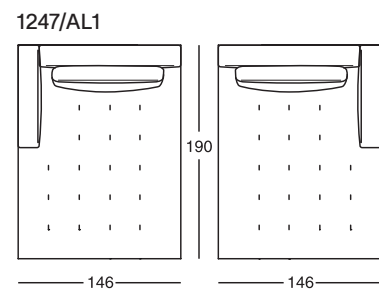
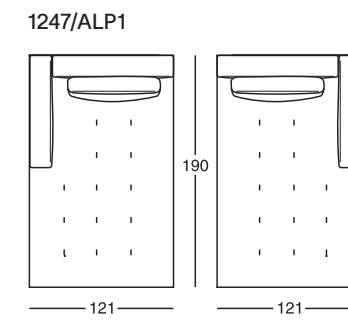
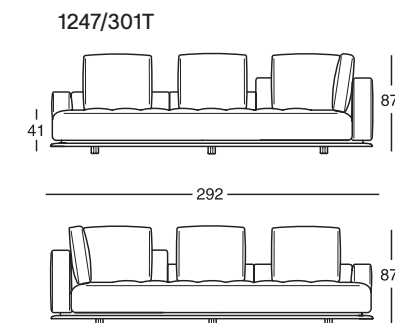
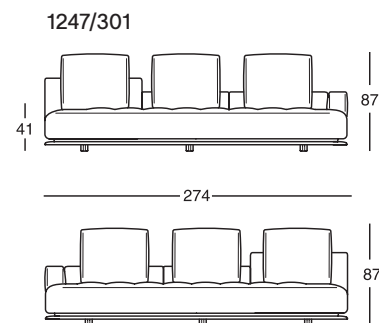

Throw-Away¹¹⁵⁰



Design

Willie Landels

1965

Poltrona, divani e pouf
Struttura in poliuretano
espanso. Rivestimento
sfilabile in stoffa o in pelle.

Armchair, sofas and pouf
Expanded polyurethane
frame. Removable cover in
fabric or leather.

Fauteuil, canapés et pouf
Structure en polyurethane
expansé. Revêtement
déhoussable en tissu ou
en cuir.

Sessel, Sofas und Hocker
Gestell aus Polyurethan-
Schaum. Abnehmbarer
Bezug aus Stoff oder Leder.

Butaca, sofas y puf
Estructura de poliuretano
espanso. Tapizado
desenfundable de tejido o
de piel.

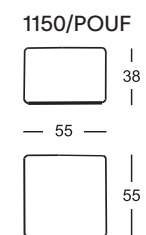
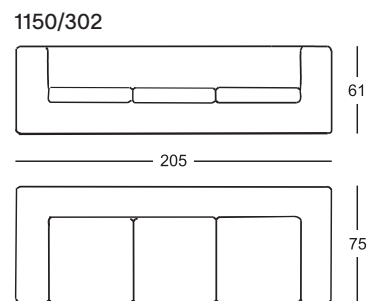
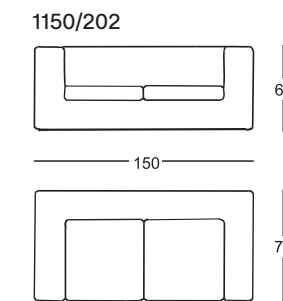
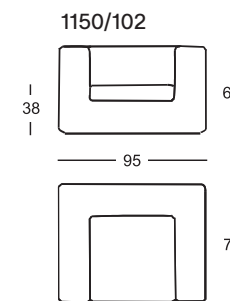



Design

Damian Williamson

2010-2015

Poltrona, divani monoblocco, componibili, pouf, dormeuse e mensole
Piedini in lega di alluminio lucidato, nichelsatinato colore naturale o nero, oppure verniciato nero. Struttura in acciaio. Molleggio su nastri elastici. Imbottitura in poliuretano/fibra poliestere termolegata. Cuscini seduta, schienale e bracciolo in piuma d'oca. Rivestimento sfilabile in stoffa o in pelle. Le poltrone allungate senza bracciolo e i divani terminali sono predisposti per l'attacco

di una mensola in legno massello di frassino tinto rovere o tinto grigio oppure in noce Canaletto verniciato colore naturale. Reggi-mensola in alluminio lucidato, nichelsatinato colore naturale o nero, o verniciato nero.

Armchair, monobloc, modular sofas, pouf, day bed and shelves
Aluminum alloy feet, either polished or with natural or black nickel-satin finish, or black painted. Steel frame. Elastic strips suspension. Upholstery in polyurethane/heat-bound polyester fibre. Seat, back and armrest cushions upholstered with goose down. Removable fabric or leather cover. The lounge chairs without armrest and the end-sofas are fit to arrange a solid wood shelf, in oak-or grey

stained ash or in natural painted Canaletto walnut. Shelf supports in polished, with natural or black nickel-satin finish, or black painted aluminum.

Fauteuil, canapés monoblocs, composables, pouf, dormeuse et étagères
Pieds en alliage d'aluminium poli, ou nickel-satiné, dans les couleurs naturel ou noir, ou verni noir. Piétement en acier. Suspension sur sangles élastiques. Rembourrage en polyuréthane/fibre polyester liée à chaud. Coussins d'assise, dossier et accoudoirs en plume d'oie. Revêtement déhoussable en tissu ou en cuir. Les fauteuils allongés sans accoudoir et les canapés composables

sont prédisposés pour l'accrochage d'une étagère en bois massif en frêne teinté rouvre ou gris ou en noyer Canaletto verni naturel. Supports d'étagère en aluminium poli, ou nickel satiné, dans les couleurs naturel ou noir, ou verni noir.

Sessel, einteilige, zusammenstellbare Sofas, Hocker, Liege und Stützfläche
Füße aus polierter Aluminiumlegierung, oder mit naturfarben- oder schwarz vernickeltem und mattiertem Finish, oder schwarz lackiert. Gestell aus Stahl. Federung auf elastischen Gurten. Polsterung aus Polyurethan/wärmegebundener Polyesterfaser. Sitz-, Rücken und Armlehnen-Polsterung aus Gänsefedern. Abnehmbarer Bezug aus

Stoff oder Leder. Die Liegesessel ohne Armlehne und die zusammenstellbaren Sofas werden zur Befestigung einer Stützfläche ausgestattet, die entweder aus massivem Eschenholz in Eiche oder graufarben oder aus naturfarben lackiertem Nussbaum Canaletto erhältlich ist. Stützfläche-Träger aus poliertem Aluminium, oder mit naturfarben- oder schwarz vernickeltem und mattiertem Finish, oder schwarz lackiert.

Butaca, sofás monobloque, modulares, púf, butacas alargadas y repisas
Patatas de aleación de aluminio pulido o niquelado mate en los acabados natural o negro, o pintado negro. Estructura de acero. Suspensión sobre cintas elásticas. Acolchado de poliuretano/fibra poliéster termounida. Cojines asiento, respaldo y apoyabrazo de pluma de ganso. Tapizado desenfundable de tejido o de piel. Las butacas alargadas sin apoyabrazos y los sofás modulares se

preparan para fijar una repisa en madera maciza de fresno teñido roble o gris, o en nogal Canaletto pintado color natural. Soportes de las repisas en aluminio pulido o niquelado mate en los acabados natural o negro, o pintado negro.

Piedini/Feet/Pieds/Füße/Patas



Reggi Mensole/Shelf supports/Supports d'étagère/Stützfläche-Träger/Soportes repisa



Frassino tinto grigio/Grey varnished ash/ Frêne teinté gris/ Grau-gebeizte Esche/Fresno teñido gris



Frassino tinto rovere/ Oak varnished ash/ Frêne teinté rouvre/ Eiche gebeizte Esche/Fresno teñido roble



Noce Canaletto/ Canaletto varnished walnut/Noyer Canaletto/ Nussbaum Canaletto/Nogal Canaletto



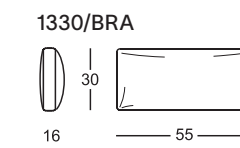
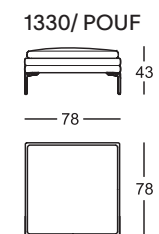
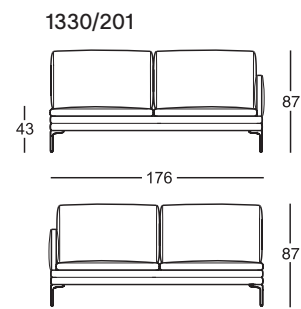
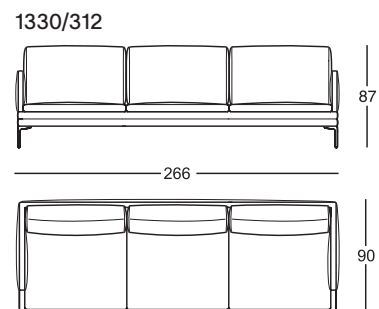
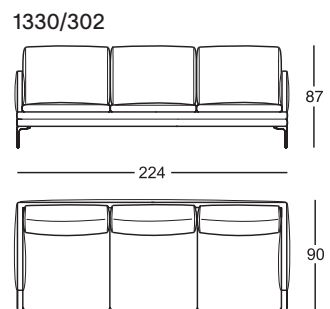
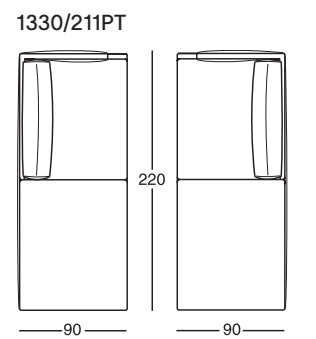
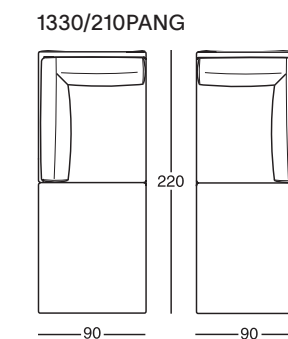
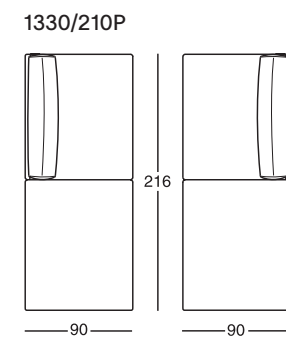
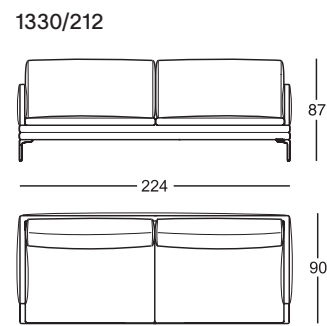
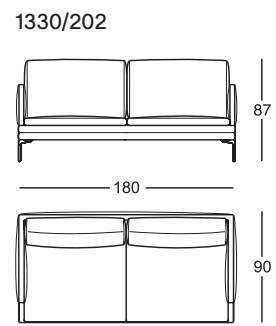
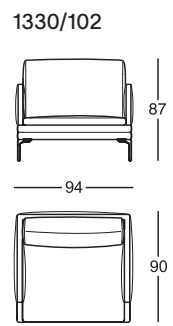
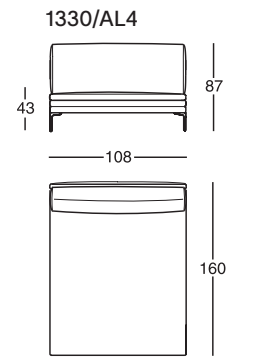
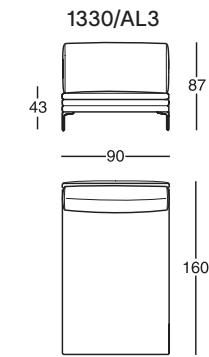
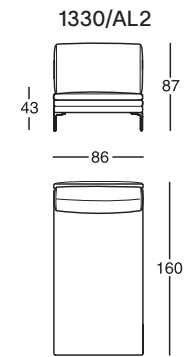
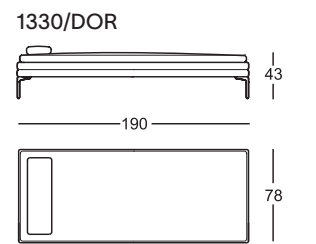
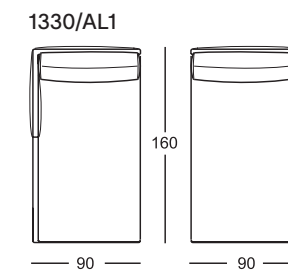
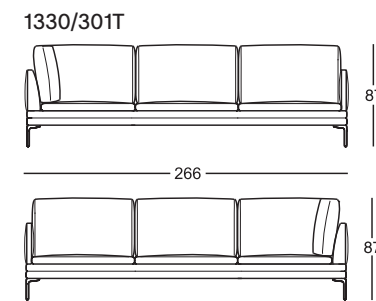
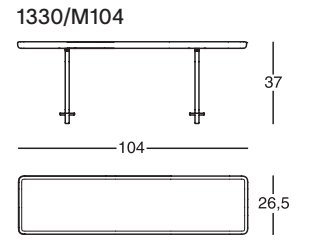
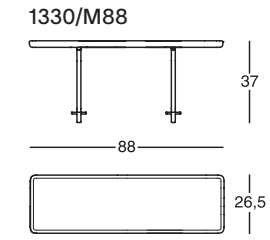
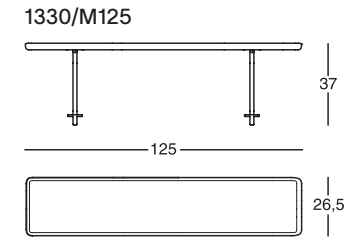
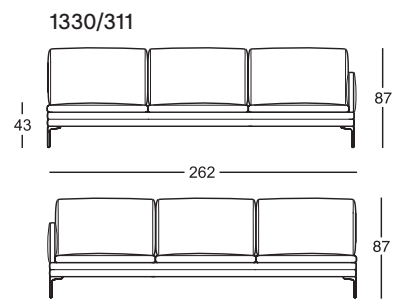
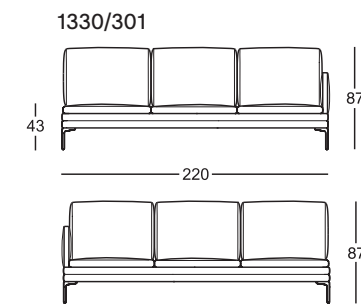
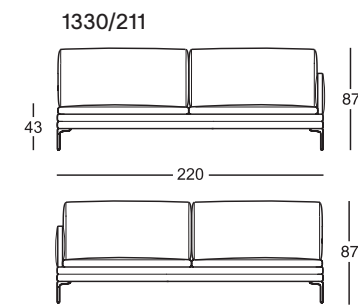

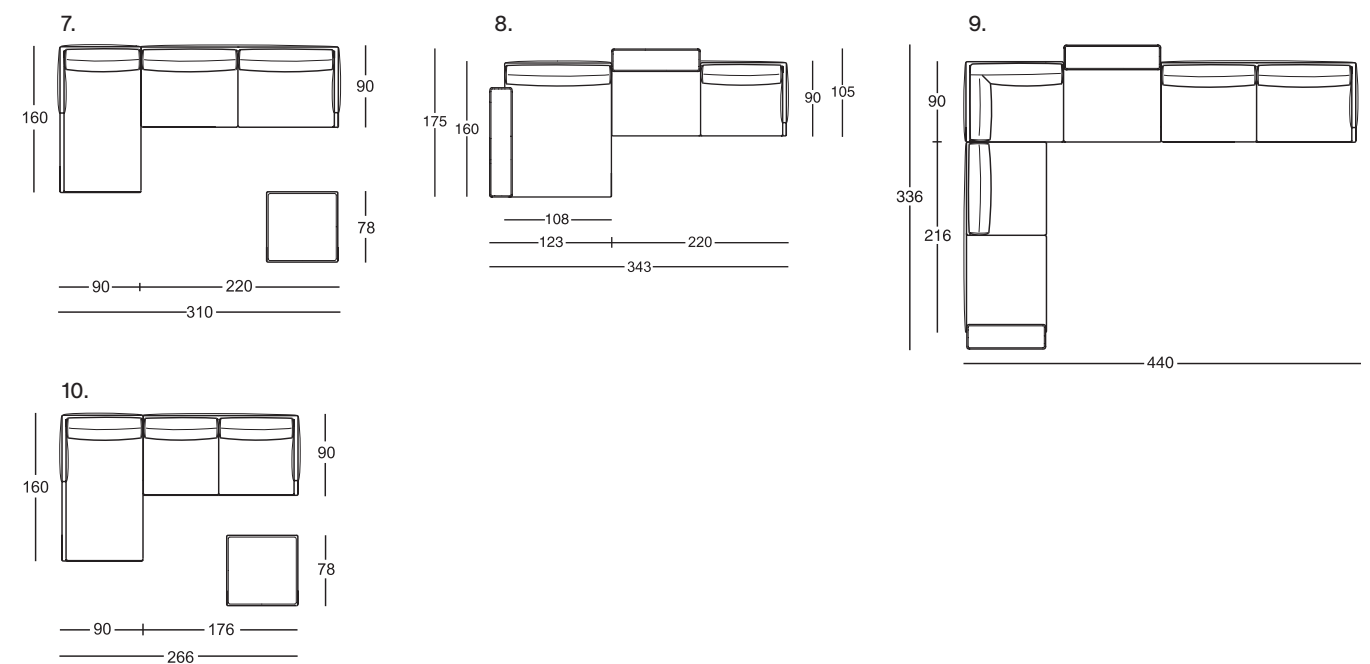
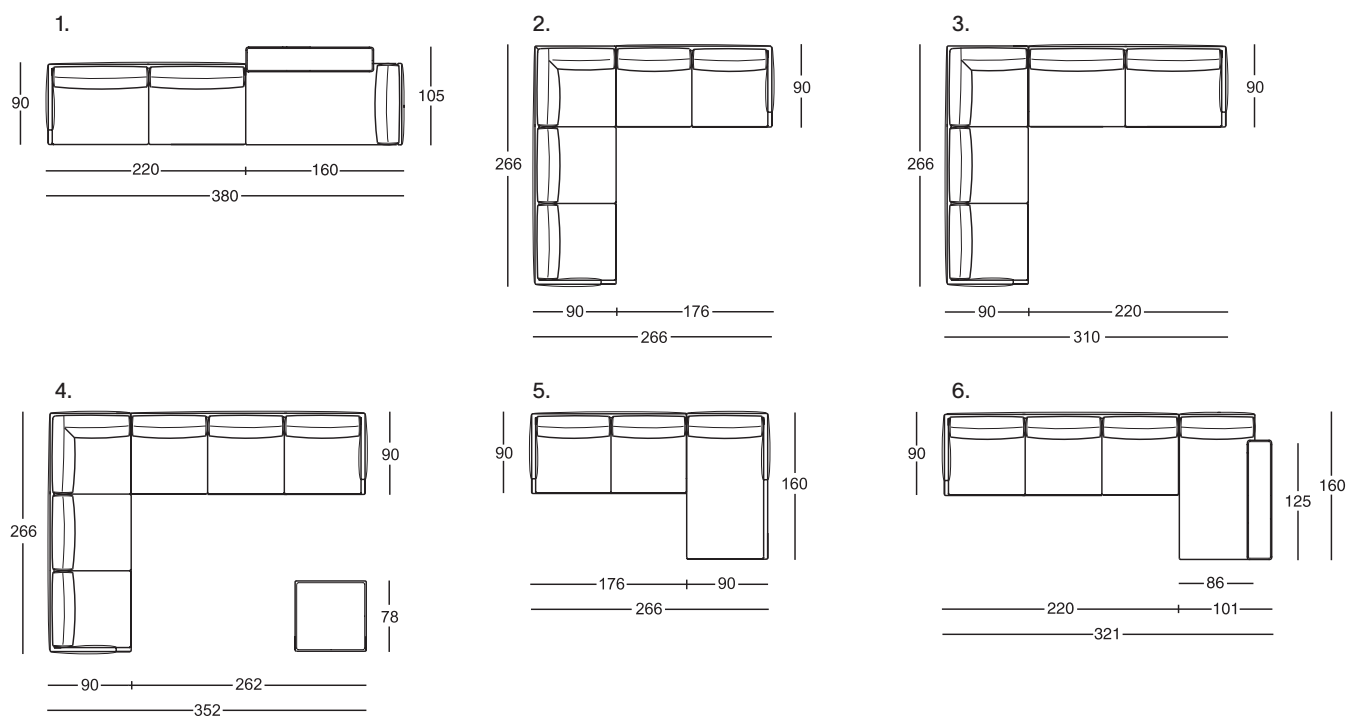



Design

Damian Williamson

2023

Divani monoblocco e componibile

Piedini in lega di alluminio lucidato, nichelsatinato colore naturale o nero, oppure verniciato nero. Struttura in acciaio. Molleggio su nastri elastici. Imbottitura seduta in poliuretano espanso a quote differenziate/fibra poliestere termolegata. Imbottitura schienale e braccioli in poliuretano schiumato autoestinguente/fibra poliestere termolegata. Imbottitura cuscino seduta e cuscino schienale in sfere di poliestere rigenerato e rigenerabile con inserto in poliuretano a quote differenziate. Rivestimento sfilabile in stoffa o in pelle.

Monobloc and modular sofas

Aluminum alloy feet, either polished or with natural or black nickel-satin finish, or black painted. Steel frame. Elastic strips suspension. Seat upholstered with graduated polyurethane foam/heat-bound polyester fibre. Upholstery of back and armrest in self-extinguishing polyurethane foam/heat-bound polyester fibre. Seat and back cushions upholstered with regenerated and regenerable polyester balls with graduated polyurethane insert. Removable fabric or leather cover.

Canapés monoblocs et composables

Pieds en alliage d'aluminium poli, ou nickel-satiné, dans les couleurs naturel ou noir, ou verni noir. Piétement en acier. Suspension sur sangles élastiques. Rembourrage de l'assise en mousse de polyuréthane à densité différenciée/fibre de polyester liée à chaud. Rembourrage dossier et accoudoirs en mousse de polyuréthane autoextinguible/fibre polyester liée à chaud. Coussin d'assise et de dossier en sphères de polyester régénéré et régénérable avec insert en polyuréthane à densité différenciée. Revêtement déhoussable en tissu ou en cuir.

Einteilige und zusammenstellbare Sofas

Füße aus polierter Aluminiumlegierung, oder mit naturfarben- oder schwarz- vernickeltem und mattiertem Finish, oder schwarz lackiert. Gestell aus Stahl. Federung auf elastischen Gurten. Sitzpolsterung aus Polyurethan mit unterschiedlicher Dichte/wärmegebundener Polyesterfaser. Rücken- und Armlehnenpolsterung aus selbstlöschendem Polyurethanschaum/wärmegebundener Polyesterfaser. Sitzkissen und Rückenkissen mit regenerierten und regenerierbaren Polyesterkugeln mit Einsatz aus Polyurethan mit unterschiedlicher Dichte. Abnehmbarer Bezug aus Stoff oder Leder. Sofás monobloque y

modulares

Patas en aleación de aluminio pulido o niquelado mate en los acabados natural o negro, o pintado negro. Estructura en acero. Suspensión sobre cintas elásticas. Acolchado del asiento de poliuretano a densidad diferenciada/fibra poliéster termounida. Acolchado del respaldo y apoyabrazo en espuma de poliuretano autoextintivo/fibra poliéster termounida. Cojín asiento y cojín respaldo acolchados con bolas de poliéster regenerado y regenerable con inserción de poliuretano a densidad diferenciada. Tapizado desenfundable de tejido o de piel.

1331/201

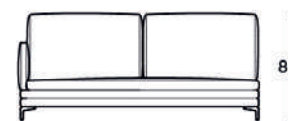
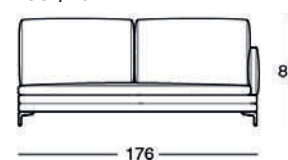

1331/212

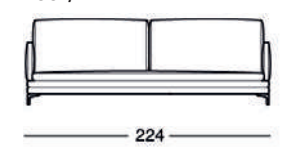

1331/302

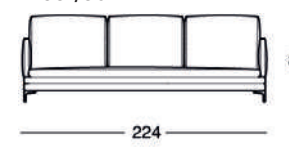

1331/312

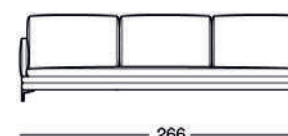

Piedini/Feet/Pieds/Füße/Patas





Design

Zaven

2022

Divani monoblocco
Struttura portante in acciaio verniciato colore arancione, amaranto, verde prato o nero dotata di nastri rigidi in poliestere colore antracite per il supporto dei cuscini. Cuscini seduta, schienale e braccioli in poliuretano/ fibra in PET riciclato. Assemblaggio imbottiture privo di collanti. Rivestimento sfilabile in stoffa.

Monobloc sofas
Carrying frame in orange, amaranth, grass green or black painted steel, complete of stiff polyester straps in the shade anthracite for the support of the cushions. Seat, back and armrest cushions in polyurethane/ recycled PET fibre. Paddings assembly without glues. Removable fabric cover.

Canapés monoblocs
Structure porteuse en acier verni orange, rouge amarante, vert pré ou noir avec rubans rigides en polyester anthracite pour le soutien des coussins. Coussins d'assise, dossier et accoudoir en polyuréthane/ fibres de PET recyclé. Assemblage du rembourrage sans adhésifs. Revêtement déhoussable en tissu.

Einteilige Sofas
Traggestell aus Orange, Amaranrot, Grasgrün oder Schwarz lackiertem Stahl mit steifen anthrazitfarbenen Polyesterbändern zur Unterstützung der Kissen. Sitz-Rücken und Armlehnen-Kissen aus Polyurethan/ recycelte PET-Faser. Polstermontage ohne Klebstoffe. Abnehmbarer Bezug aus Stoff.

Sofás monobloque
Estructura portante en acero pintado en naranja, granate, verde prado o negro con cintas rígidas de poliéster antracita para el soporte de los cojines. Cojines de asiento, respaldo y apoyabrazos en poliuretano/ fibra de PET reciclado. Montaje de los acolchados sin cola. Tapizado desenfundable de tejido.

Struttura/Frame/Structure/Gestell/Estructura

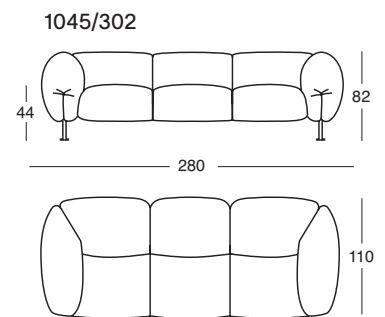
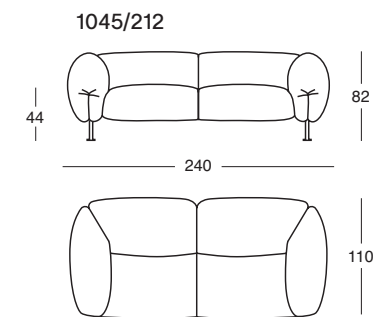
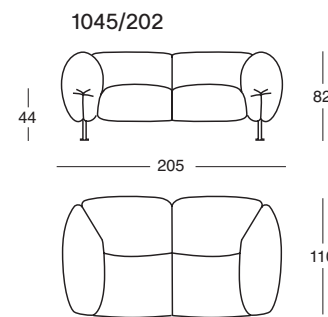

Za:Za Max ¹⁰⁴⁶

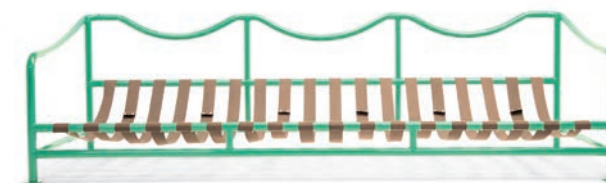

Design

Zaven

2024

Divani monoblocco, componibili e pouf.
Struttura portante in acciaio verniciato colore talco, canapa, arancione, amaranto, verde prato, espresso o nero, dotata di nastri rigidi in poliestere colore antracite per il supporto dei cuscini. Cuscini seduta, schienale e bracciolo in poliuretano/fibra in PET riciclato. Assemblaggio imbottiture privo di collanti. Rivestimento esterno sfilabile in stoffa.

Monobloc, modular sofas and pouf.
Carrying frame in talc, hemp, orange, amaranth, grass green, espresso or black painted steel, complete of stiff polyester straps in the shade anthracite for the support of the cushions. Seat, back and armrest cushions in polyurethane/ recycled PET fibre. Paddings assembly without glues. Removable fabric cover.

Canapés monoblocs, composables et pouf.
Structure porteuse en acier verni talc, chanvre, orange, rouge amarante, vert pré, espresso ou noir avec rubans rigides en polyester anthracite pour le soutien des coussins. Coussins d'assise, dossier et accoudoir en polyuréthane/fibres de PET recyclé. Assemblage du rembourrage sans adhésifs. Revêtement déhoussable en tissu.

Einteilige, zusammenstellbare Sofas und Hocker.
Traggestell aus Talkum, Hanf, Orange, Amaranth, Grasgrün, Espresso oder Schwarz lackiertem Stahl mit steifen anthrazitfarbenen Polyesterbändern zur Unterstützung der Kissen. Sitz-Rücken und Armlehnen-Kissen aus Polyurethan/ recycelte PET-Faser. Polstermontage ohne Klebstoffe. Abnehmbarer Bezug aus Stoff.

Sofás monobloque, modulares y púf.
Estructura portante en acero pintado en talco, cañamo, naranja, granate, verde prado, espresso o negro con cintas rígidas de poliéster antracita para el soporte de los cojines. Cojines de asiento, respaldo y apoyabrazos de poliuretano/ fibra de PET reciclado. Montaje de los acolchados sin cola. Tapizado desenfundable de tejido.

Struttura/Frame/Structure/Gestell/Estructura

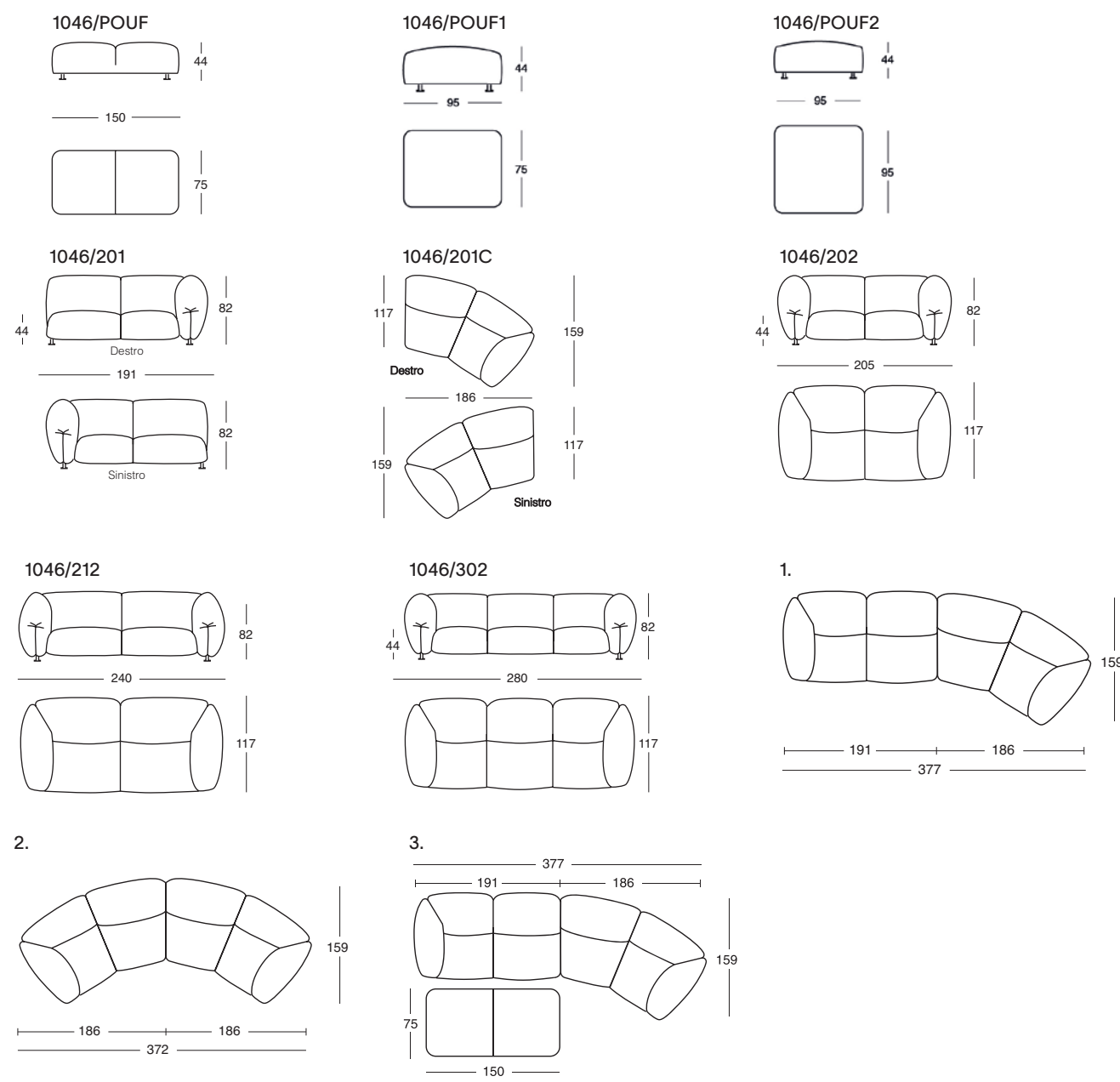



Armchairs

74–97

Poltrone
Fauteuils
Sessel
Butacas

Ardea CM 882

* Vedi nota a fine catalogo
 * See note at the end of the catalogue
 * Voir la note en fin de catalogue
 * Siehe Hinweis am Ende des Katalogs
 * Ver nota al final del catálogo



Design

Carlo Mollino

1946

Poltrona/Bergère

Base in legno massello di rovere naturale o tinto nero oppure in legno massello di noce Canaletto colore naturale; verniciatura con finitura a cera. Struttura in acciaio con molleggio su nastri elastici. Imbottitura in poliuretano/fibra poliestere termolegata. Rivestimento sfilabile in stoffa o pelle.

Armchair/Bergère

Base in solid natural or black varnished oak, or in solid natural Canaletto walnut; wax-finished varnish. Steel frame, with elastic strips suspension. Upholstery in polyurethane/heat-bound polyester fibre. Removable cover in fabric or leather.

Fauteuil/bergère

Socle en rouvre naturel massif ou teinté noir ou en noyer Canaletto massif, couleur naturelle; verni finition cirée. Structure en acier avec suspension sur sangles élastiques. Rembourrage en polyuréthane/fibre de polyester liée à chaud. Revêtement déhoussable en tissu ou en cuir.

Sessel/Bergère

Sockel aus massiver naturfarbener oder schwarz lackierter Eiche, oder aus massivem naturfarbenem Nussbaum Canaletto; Lackierung mit Wachs-Endbehandlung. Gestell aus Stahl mit Federung auf elastischen Gurten. Polsterung aus Polyhurethan/wärmegebundener Polyesterfaser. Abnehmbarer Bezug aus Stoff oder Leder.

Butaca de orejas

Base en madera maciza de roble natural o teñido negro o en madera maciza de nogal Canaletto color natural; pintura con acabado de cera. Estructura de acero con suspensión sobre cintas elásticas. Acolchado de poliuretano/fibra poliéster termounida. Tapizado desenfundable en tejido o piel.

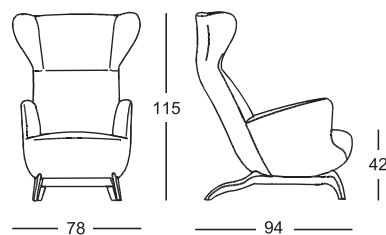

Rovere naturale/Natural oakwood/Rouvre naturel/Naturfarbene Eiche/Roble natural



Rovere tinto nero/Black varnished oak/Rouvre teinté noir/Schwarz-gebeizte Eiche/Roble teñido negro



Noce Canaletto/Canaletto walnut/Noyer Canaletto/Nussbaum Canaletto/Nogal Canaletto



Arom 872



Design

Noé Duchaufour Lawrance

2014

Poltrona

Struttura in acciaio. Imbottitura in poliuretano/fibra poliestere termolegata con molleggio su nastri elastici. Rivestimento sfilabile in stoffa o pelle. La scocca esterna può essere rivestita anche in cuoio 95 in abbinamento a tessuto o pelle.

Armchair

Steel frame. Upholstery with polyurethane/heat bound polyester fibre with elastic strips suspension. Removable cover in fabric or leather. The exterior body can be covered with cowhide 95, combined with fabric or leather.

Fauteuil

Structure en acier. Rembourrage en polyuréthane/fibre polyester liée à chaud avec suspension sur sangles élastiques. Revêtement déhoussable en tissu ou en cuir. La coque extérieure peut également être revêtue en cuir sellier 95 en combinaison avec du tissu ou de cuir.

Sessel

Gestell aus Stahl. Polsterung aus Polyurethan/wärmegebundener Polyesterfaser mit Federung auf elastischen Gurten. Abnehmbarer Bezug aus Stoff oder Leder. Die Sitzschale kann außen mit Kernleder 95 in Kombination mit Stoff oder Leder bezogen werden.

Butaca

Estructura de acero. Acolchado de poliuretano/fibra poliéster termounida con suspensión sobre cintas elásticas. Tapizado desenfundable de tejido o de piel. El bastidor exterior puede ser tapizado en cuero 95 en combinación con tejido o piel.

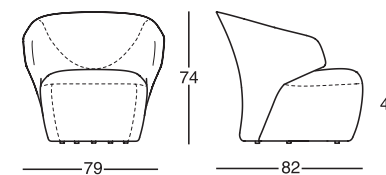

Calla ⁸⁷³



Derby ⁸⁷⁵



Design

Noé Duchaufour Lawrance

2010

Poltroncina

Base su ruote o fissa con piedini. Struttura in acciaio. Imbottitura in poliuretano/fibra poliestere termolegata con molleggio su nastri elastici. Rivestimento sfilabile in stoffa o in pelle. La scocca esterna può essere rivestita anche in cuoio 95 in abbinamento a tessuto o pelle. La poltroncina è disponibile in due differenti altezze da terra: alta 873/A con rotelle, bassa 873/B con piedini.

Small armchair

Base on castors or fixed with feet. Steel frame. Upholstery with polyurethane/heat bound polyester fibre with elastic strips suspension. Removable fabric or leather cover. The exterior body can be covered with cowhide 95, combined with fabric or leather. The armchair is available in two different heights above ground level: high 873/A with castors, low 873/B with feet.

Petit fauteuil

Base sur roulettes ou fixe avec pieds. Piètement en acier. Rembourrage de polyuréthane/fibre polyester liée à chaud avec suspension sur sangles élastiques. Revêtement déhoussable en tissu ou en cuir. La coque extérieure peut également être revêtue en cuir sellier 95 en combinaison avec du tissu ou de cuir. Le fauteuil est disponible en deux hauteurs du sol: haut 873/A avec roulettes, bas 873/B avec pieds.

Kleiner Sessel

Sockel auf Rollen oder fest mit Füßen. Gestell aus Stahl. Polsterung aus Polyurethan/wärmegebundener Polyesterfaser mit Federung auf elastischen Gurten. Abnehmbarer Bezug aus Stoff oder Leder. Die Sitzschale kann außen mit Kernleder 95 in Kombination mit Stoff oder Leder bezogen werden. Der kleine Sessel ist in zwei verschiedenen Höhen ab Boden erhältlich: hoch 873/A mit Rollen, niedrig 873/B mit Füßen.

Butaquita

Base sobre ruedas o fija con patas. Estructura de acero. Acolchado de poliuretano/fibra poliéster termounida con suspensión sobre cintas elásticas. Tapizado desenfundable de tejido o de piel. El bastidor exterior puede ser tapizado en cuero 95 en combinación con tejido o piel. La butaquita está disponible en dos alturas diferentes: alto 873/A con ruedas, bajo 873/B con patas.

873/A

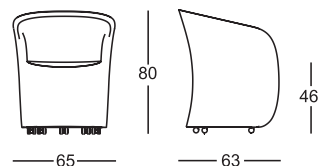

873/B

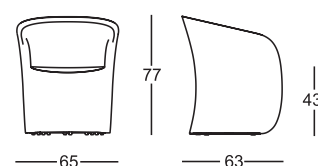

Design

Noé Duchaufour Lawrance

2009-2010

Poltrona/bergère, pouf

Poltrona con base girevole in acciaio o fissa con piedini e scocca esterna in poliuretano rigido rivestita in cuoio 95. Imbottitura scocca interna e pouf in poliuretano/fibra poliestere termolegata con molleggio su nastri elastici. Rivestimento sfilabile in stoffa o in pelle. Struttura pouf in acciaio.

Armchair/bergère, pouf

Armchair with steel base, swivel or fixed with feet and stiff polyurethane exterior body covered with cowhide 95. Upholstery of internal body and pouf in polyurethane/heat-bound polyester fibre with elastic strips suspension. Removable fabric or leather cover. Pouf steel frame.

Fauteuil/Bergère, pouf

Fauteuil avec base pivotante en acier ou fixée avec pieds et coque extérieure en polyuréthane rigide, revêtue en cuir sellier 95. Rembourrage de la coque intérieure et pouf en polyuréthane/fibre polyester liée à chaud avec suspension sur sangles élastiques. Revêtement déhoussable en tissu ou en cuir. Structure pouf en acier.

Sessel/Bergère, Hocker

Sessel mit Stahlsockel, drehbar oder fest mit Füßen und äußere Sitzschale aus steifem Polyurethan, mit Kernleder 95 bezogen. Innere Sitzschale und Hocker mit Polsterung aus Polyurethan/wärmegebundener Polyesterfaser mit Federung auf elastischen Gurten. Abnehmbarer Bezug aus Stoff oder Leder. Hocker-Gestell aus Stahl.

Sillón/bergère, puf

Sillón con base giratoria de acero o fija con pies y bastidor exterior de poliuretano tapizado de cuero 95. Acolchado del bastidor interior y del puf de poliuretano/fibra poliéster termounida con suspensión sobre cintas elásticas. Tapizado desenfundable de tejido o de piel. Estructura puf de acero.

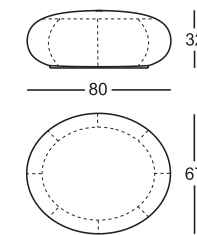
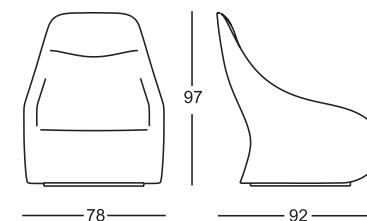

Galeotta ⁸⁷⁷



Design

De Pas, D'Urbino, Lomazzi

1968-2023

Poltrona trasformabile
Struttura in poliuretano espanso a quote differenziate. Rivestimento sfilabile in stoffa.

Convertible armchair
Frame in graduated polyurethane foam. Removable fabric cover.

Fauteuil transformable
Structure en mousse de polyuréthane à densité variable. Revêtement déhoussable en tissu.

Umwandelbarer Sessel
Gestell aus Polyurethanschaum mit unterschiedlicher Dichte. Abnehmbarer Bezug aus Stoff.

Sillón convertible
Estructura en espuma de poliuretano a densidades diferenciadas. Tapizado desenfundable en tejido.

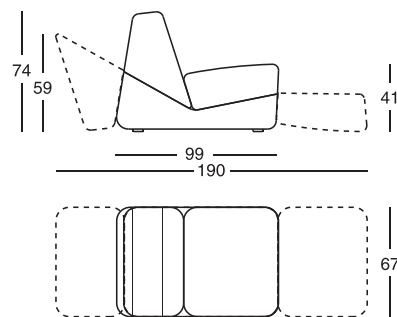

Genni ⁹²⁰



Design

Gabriele Mucchi

1935

Chaise longue
Struttura in acciaio cromato, o nichel satinato colore naturale o nero, oppure verniciato arancione o nero. Molleggio su spirali di acciaio. Seduta regolabile su due posizioni. Imbottitura cuscino seduta e poggiatesta in poliuretano. Rivestimento cuscini e braccioli in pelle.

Lounge chair
Chromium-plated steel frame or with natural or black nickel-satin finish, or orange or black painted. Suspension on steel springs. Adjustable seat in two positions. Cushion and headrest upholstered in polyurethane. Leather-covered cushions and armrests.

Chaise longue
Structure en acier chromé, nickel satiné, dans les finitions naturelle ou noire, ou en acier verni orange ou noir. Suspension à spirales d'acier. Assise réglable en deux positions. Coussin et appuie-tête en polyuréthane. Revêtement coussins et accoudoirs en cuir.

Chaiselongue
Gestell aus verchromtem, orange oder schwarz-lackiertem Stahl, oder mit naturfarben- oder schwarz-vernicheltem und mattiertem Finish. Federung auf Stahlfedern. Sitzhöhe zweifach regulierbar. Kissen und Kopfrolle aus Polyurethan. Kissen- und Armlehnenbezug aus Leder.

Sillón
Estructura de acero cromado, o niquelado mate en los acabados natural o negro, o pintada de color naranja o negro. Muelles de espiral de acero. Asiento regulable en dos posiciones. Cojín y apoyacabeza acolchados de poliuretano. Tapizado cojines y apoyabrazos de piel.

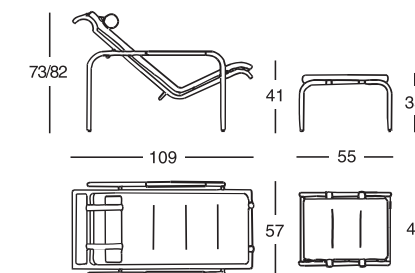

Struttura/Frame/Structure/Gestell/Estructura



Gilda CM 888

* Vedi nota a fine catalogo
 * See note at the end of the catalogue
 * Voir la note en fin de catalogue
 * Siehe Hinweis am Ende des Katalogs
 * Ver nota al final del catálogo



Gomma 840



Design

Carlo Mollino

1953

Poltrona

Struttura in rovere naturale o tinto nero oppure in noce Canaletto colore naturale; verniciatura con finitura a cera. Parti metalliche in ottone nichelsatinato colore nero. Schienale regolabile su quattro posizioni. Imbottitura in poliuretano / fibra poliestere termolegata con molleggio su spirali d'acciaio. Rivestimento sfilabile in stoffa o in pelle.

Armchair

Frame in natural or black varnished oak, or in natural Canaletto walnut; wax-finished varnish. Black-nickel satin finished brass metal components. Four-position adjustable backrest. Upholstery in polyurethane/heat-bound polyester fibre with suspension on steel springs. Removable fabric or leather cover.

Fauteuil

Structure en rouvre naturel ou teinté noir ou en noyer Canaletto, couleur naturelle; verni finition cirée. Quincaillerie en laiton nickel satiné couleur noire. Dossier réglable sur quatre positions. Rembourrage en polyuréthane/fibre de polyester liée à chaud avec suspension à spirales d'acier. Revêtement déhoussable en tissu ou en cuir.

Sessel

Gestell aus naturfarbener oder schwarz lackierter Eiche, oder aus naturfarbenem Nussbaum Canaletto; Lackierung mit Wachs-Endbehandlung. Metallteilen aus Messing mit schwarz- vernickelter und matterter Ausführung. Rückenlehne in vier Positionen verstellbar. Polsterung aus Polyhurethan/wärmegebundener Polyesterfaser mit Federung auf Stahlfedern. Abnehmbarer Bezug aus Stoff oder Leder.

Butaca

Estructura de roble natural o teñido negro o de nogal Canaletto color natural; pintura con acabado de cera. Herrajes de latón niquelado color mate negro. Respaldo regulable en cuatro posiciones. Acolchado de poliuretano/fibra de poliéster termounida con suspensión de espirales de acero. Tapizado desenfundable de tejido o de piel.

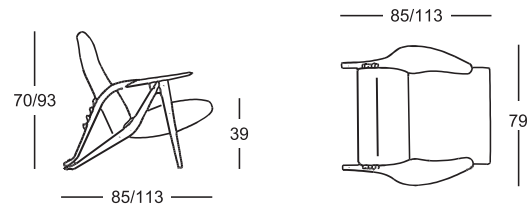

Design

De Pas, D'Urbino, Lomazzi

1970

Poltrona

Struttura in legno multistrato con molleggio su nastri elastici e piedi in legno massello di faggio. Imbottitura amovibile in poliuretano schiumato con polioli a base vegetale. Assemblaggio privo di collanti. Rivestimento amovibile in stoffa.

Armchair

Multilayer wooden frame with elastic strip suspension and solid beech feet. Removable polyurethane foam upholstery with vegetable-based polyols. Glue-free assembly. Removable fabric cover.

Fauteuil

Structure en bois multicouche avec suspension sur sangles élastiques et pieds en hêtre massif. Rembourrage amovible en mousse de polyuréthane avec polyols d'origine végétale. Assemblage sans colle. Revêtement amovible en tissu.

Sessel

Sperrholzgestell mit Federung auf elastischen Gurten und Füßen aus massiver Buche. Abnehmbare Polyurethanschaum-Polsterung mit Polyolen auf pflanzlicher Basis. Leimfreie Montage. Abnehmbarer Bezug aus Stoff.

Butaca

Armazón de madera multicapa con suspensión sobre cintas elásticas y patas de haya maciza. Acolchado desenfundable de espuma de poliuretano con polioles vegetales. Montaje sin cola. Tapizado desenfundable en tejido.

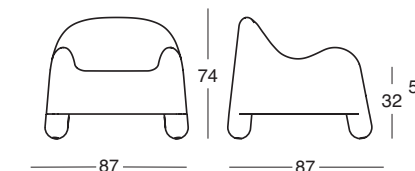

Karelia ⁸⁷⁰



Design

Liisi Beckmann

1966

Poltrona

Struttura in poliuretano espanso a quote differenziate. Rivestimento sfilabile realizzabile solo nei tessuti Terso e Quantum.

Armchair

Graduated polyurethane foam frame. Removable cover only available in the fabrics Terso and Quantum.

Fauteuil

Structure en mousse de polyuréthane à densité variable. Revêtement déhoussable seulement dans les tissus Terso et Quantum.

Sessel

Gestell aus Polyurethanschaum in unterschiedlicher Dichte. Abnehmbarer Bezug nur mit den Stoffen Terso und Quantum.

Butaca

Estructura en espuma de poliuretano a densidades diferenciadas. Tapizado desenfundable solo en los tejidos Terso y Quantum.

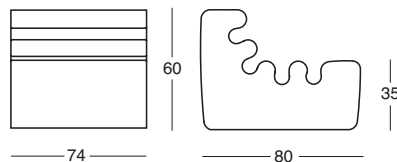

Kent ⁸⁹⁶



Design

Palomba Serafini Associati

2013

Poltrona/bergère. Pouf

Base girevole in acciaio verniciato, colore nero o grafite. Struttura in acciaio. Imbottitura in poliuretano/fibra poliestere termolegata. Rivestimento sfilabile in stoffa o in pelle

Armchair/bergère. Pouf

Revolving base in varnished steel, colours: black or graphite. Steel frame. Upholstery in polyurethane/heat-bound polyester fibre. Removable fabric or leather cover.

Fauteuil/bergère. Pouf

Piètement pivotant en acier verni, couleur noire ou graphite. Structure en acier. Rembourrage de polyuréthane/fibre polyester liée à chaud. Revêtement déhoussable en tissu ou en cuir.

Sessel/bergère. Hocker

Drehbarer Stahlsockel, graphitfarben oder schwarz lackiert. Stahlgestell. Polsterung aus Polyurethan/wärmegebundener Polyesterfaser. Abnehmbarer Bezug aus Stoff oder Leder.

Butaca/bergère. Púf

Base giratoria de acero barnizado, color negro o grafito. Estructura de acero. Acolchado de poliuretano/fibra poliéster termounida. Tapizado desenfundable de tejido o de piel.

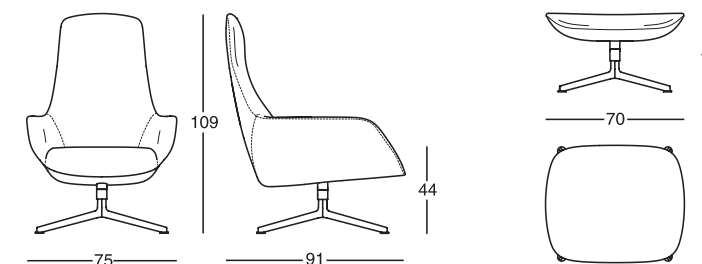

Base/Base/Piètement/Socket/Base



Lama ⁹²¹



Design

Palomba Serafini Associati

2006

Chaise longue

Struttura in acciaio verniciato, colore grafite. Imbottitura in poliuretano con molleggio su nastri elastici. Rivestimento sfilabile in stoffa o pelle, o non sfilabile in cuoio.

Lounge chair

Graphite varnished steel frame. Polyurethane upholstery with elastic strips suspension. Removable cover in fabric or leather, or non-removable in cowhide.

Chaise longue

Structure en acier verni, couleur graphite. Rembourrage de polyuréthane avec suspensions sur sangles élastiques. Revêtement déhoussable en tissu ou cuir, ou pas déhoussable en cuir sellier.

Chaiselongue

Lackiertes Stahlgestell, Graphitfarben. Polsterung aus Polyurethan auf elastischen Gurten. Abnehmbarer Bezug aus Stoff oder Leder, oder nicht abnehmbar aus Kernleder.

Sillón

Estructura de acero pintado color grafito. Acolchado de poliuretano sobre cintas elásticas. Tapizado desenfundable en tejido o piel, o non desenfundable en cuero.

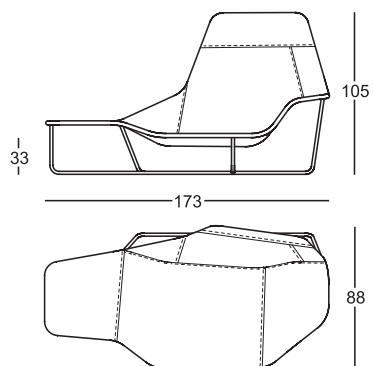

Maggiolina ⁹⁰⁰



Design

Marco Zanuso

1947

Chaise longue

Struttura in acciaio inox lucidato, o nichelsatinato colore naturale o nero, oppure verniciato arancione o nero. Scocca in cuoio pigmentato 90. Imbottitura cuscino schienale in piuma d'oca. Imbottitura cuscino seduta in poliuretano/Dacron Du Pont. Rivestimento cuscini in stoffa, Ecofire o pelle. Rivestimento braccioli in pelle o Ecofire.

Lounge chair

Polished, orange- or black painted steel tubular frame, or with natural or black nickel-satin finish. Sling in cowhide pigmentato 90. Back cushion in new goose feathers. Seat cushion upholstered in polyurethane/Dacron Du Pont. Cushions covered with fabric, Ecofire or leather. Armrests covered with leather or Ecofire.

Chaise longue

Structure en acier inox poli, nickel satiné dans les finitions naturelle ou noire, ou verni couleur orange ou noire. Support en cuir sellier pigmentato 90. Coussin dossier en plume d'oie. Coussin assise en polyuréthane/Dacron Du Pont. Revêtement coussins en tissu, Ecofire ou cuir. Accoudoirs en cuir ou Ecofire.

Chaiselongue

Gestell aus poliertem, orange- oder schwarz lackiertem Inox-Stahl oder mit naturfarben- oder schwarz- vernickeltem und mattiertem Finish. Tragschale aus Kernleder pigmentato 90. Rückenkissen gefüllt mit reinen Gänsefedern. Sitzkissen aus Polyurethan/Dacron Du Pont. Kissen-Bezug aus Stoff, Ecofire oder Leder. Armlehnen-Bezug aus Leder oder Ecofire.

Sillón

Estructura de acero inox pulido o niquelado mate en los acabados natural o negro, o pintado de color naranja o negro. Soporte para los cojines de cuero pigmentato 90. Cojín respaldo acolchado de plumas de ganso. Cojín asiento acolchado de poliuretano/Dacron Du Pont. Tapizado cojines de tejido, Ecofire o piel. Tapizado apoyabrazos de piel o Ecofire.

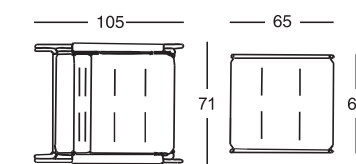
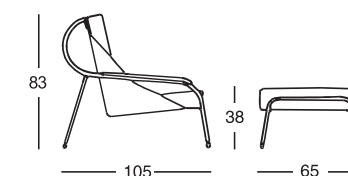

Struttura/Frame/Structure/ Gestell/Estructura



Nena Lounge ⁹²⁸



Oliva ⁸⁸³



Design

Lanzavecchia + Wai

2023

Poltrona

Struttura in acciaio verniciato colore amaranto, espresso, grafite o nero. Imbottitura sedile in poliuretano a quote differenziate/ Dacron Du Pont, imbottitura schienale in poliuretano schiumato autoestinguente. Rivestimento sfilabile in stoffa o in pelle.

Armchair

Steel frame varnished amaranth, espresso, graphite or black. Seat upholstered in graduated polyurethane/ Dacron Du Pont; backrest upholstered with self-extinguishing polyurethane foam. Removable cover in fabric or leather.

Fauteuil

Structure en acier verni rouge amarante, espresso, graphite ou noir. Assise rembourré en polyuréthane à densité variable/Dacron Du Pont, dossier rembourré en mousse de polyuréthane autoextinguible. Revêtement déhoussable en tissu ou en cuir.

Sessel

Gestell aus Amaranthrot, Espresso, Graphitfarben oder schwarz lackiertem Stahl. Sitz -Polsterung aus Polyurethan mit unterschiedlicher Dichte/ Dacron Du Pont. Rückenlehne mit selbstlöschendem Polyurethanschaum gepolstert. Abnehmbarer Bezug aus Stoff oder Leder.

Butaca

Estructura de acero pintado en los colores granate, espresso, grafito o negro. Acolchado del asiento de poliuretano a densidades diferenciadas/Dacron Du Pont; acolchado del respaldo de espuma de poliuretano autoextintivo. Tapizado desenfundable de tejido o piel.

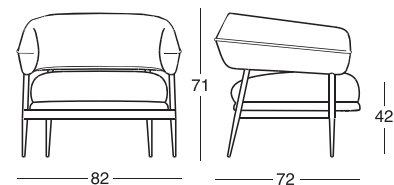

Struttura/Frame/Structure/ Gestell/Estructura



Design

Constance Guisset

2019

Poltrona

Gambe in legno massello di acero laccato nero. Struttura in acciaio. Imbottitura in poliuretano/fibra poliestere termolegata. Rivestimento sfilabile in stoffa o pelle.

Armchair

Legs in black laquered solid maple wood. Steel frame. Upholstery with self-extinguishing polyurethane foam/heat-bound polyester fibre. Removable cover in fabric or leather.

Fauteuil

Pieds en bois massif d'érable laqué noir. Structure en acier. Rembourrage en mousse de polyuréthane autoextinguible/fibre de polyester liée à chaud. Revêtement déhoussable en tissu ou en cuir.

Sessel

Beine aus schwarz lackiertem massiven Ahornholz. Stahl-Gestell. Polsterung aus selbstlöschendem Polyurethan-Schaum/wärmegebundener Polyesterfaser. Abnehmbarer Bezug aus Stoff oder Leder.

Butaca

Patas de madera maciza de arce lacada negro. Estructura de acero. Acolchado de espuma de poliuretano autoextintivo/fibra poliéster termounida. Tapizado desenfundable de tejido o de piel.

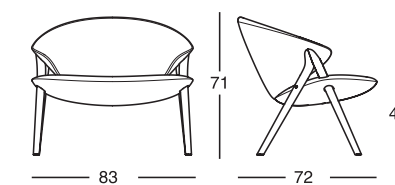



Design

Monica Armani

2026

Poltrona vis à vis e poltrona
Gambe e pomoli schienale in frassino tinto rovere o tinto moka o laccato poro aperto nei colori talco, arancione, amaranth e nero. Imbottitura sedile a quote differenziate di poliuretano CIRCULARREFOAM® composto da una percentuale di polioli riciclati/fibra in PET con una percentuale di riciclato post-consumo. Imbottitura

schienale in poliuretano schiumato auto-estinguente con una percentuale di polioli di origine biologica a quote differenziate/tessuto elastico in poliestere. Rivestimento esterno sfilabile in stoffa o in pelle.

Armchair
Legs and backrest knobs in oak - or mocha varnished ash, or open-pore lacquered in talc, orange, amaranth and black. Seat padding in CIRCULARREFOAM® polyurethane of varying densities composed of a percentage of recycled polyols/PET fibre including a percentage of post-consumer recycled material. Backrest padding in self-

extinguishing polyurethane foam with a percentage of bio-based polyols in varying proportions/elastic polyester fabric. Removable external cover in fabric or leather.

Fauteuil
Pieds et boutons du dossier en frêne teinté rovere ou moka, ou laqué à pores ouverts dans les couleurs talc, orange, rouge amaranth et noir. Rembourrage de l'assise en polyuréthane CIRCULARREFOAM® à densités variables, composé d'un pourcentage de polyols recyclés/fibres de PET, dont une partie provient de matériaux recyclés

post-consommation. Rembourrage du dossier en mousse de polyuréthane auto-extinguible avec un pourcentage de polyols d'origine biologique à densités variables/tissu élastique en polyester. Revêtement extérieur déhoussable en tissu ou en cuir.

Sessel
Beine und Rückenlehnenknöpfe aus Esche, gebeizt in Eiche oder Mokka, oder offenporig lackiert in den Farben Talkum, Orange, Amaranth und Schwarz. Sitzpolsterung aus CIRCULARREFOAM®-Polyurethan mit unterschiedlichen Dichten, das einen Anteil an recycelten Polyölen und PET-Fasern enthält,

darunter auch ein Anteil an Post-Consumer-Recyclingmaterial. Rückenpolsterung aus selbstlöschendem Polyurethanschaum mit einem Anteil an Polyölen biologischen Ursprungs in unterschiedlichen Anteilen/elastischem Polyestergewebe. Abnehmbarer Außenbezug aus Stoff oder Leder.

Butaca
Patas y botones del respaldo de fresno teñido en roble o moka, o lacados a poro abierto en los colores talco, naranja, granate y negro. Asiento acolchado con densidades diferenciadas de poliuretano CIRCULARREFOAM®, compuesto por un porcentaje de polioli reciclados/fibra de PET con

un porcentaje de material reciclado postconsumo. Respaldo acolchado con espuma de poliuretano autoextinguible con un porcentaje de polioli de origen biológico con densidades diferenciadas/tejido de poliéster elástico. Tapizado exterior desenfundable de tejido o piel.

898

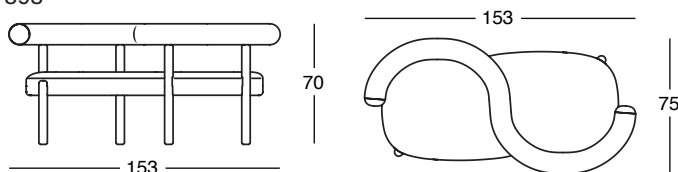

899

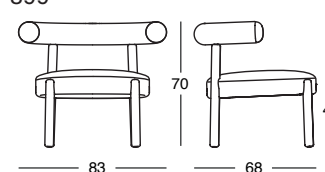

Struttura/Frame/Structure/Gestell/Estructura



Sacco Small ²⁷⁸

Sacco Medium ²⁷⁹

Sacco ²⁸⁰



Design

Gatti, Paolini, Teodoro

1968

IN/OUT

Poltrone anatomiche
Involucro contenente palline di polistirolo espanso ad alta resistenza. Rivestimento in tessuto Tux, Vip (anche per esterni, antibatterico e antimacchia con trattamento Permablock 3') e pelle.

Anatomical easy chairs
Envelope containing highly resistant expanded polystyrene pellets. Cover in fabric Tux, Vip (also for outdoor, antibacterial and stainproof with Permablock 3' treatment) and leather.

Fauteuils anatomiques
Housse contenant de petites billes de polystyrene à grande résistance. Revêtement en tissu Tux, Vip (aussi pour extérieurs, antibactérien et antitache avec traitement Permablock 3') et cuir.

Anatomische Sessel
Hülle mit aufgeschäumten Polystyrol-Kügelchen gefüllt, widerstandsfähig. Bezug aus dem Stoff Tux, aus Vip (auch fürs Freie, antibakteriell und Fleckenschutz mit Behandlung Permablock 3') und Leder.

Butacas anatómicas
Bolsa rellena de bolitas de poliestirol expanso de alta resistencia. Tapizado en tejido Tux, en Vip (también para exteriores, antibacteriano y antimancha con tratamiento Permablock 3') y piel.

278

279

280

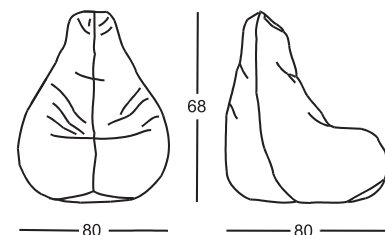
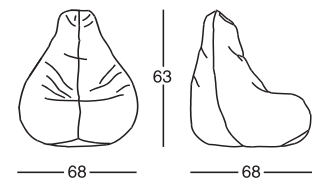
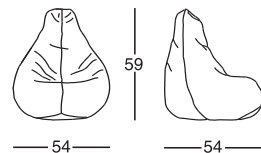

Rivestimento/Cover/Revêtement/Bezug/Tapizado

VIP

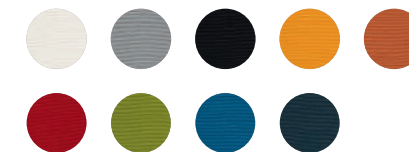

TUX



Sant'Elia ⁸⁵⁰



Design

Giuseppe Terragni

1936

Poltroncina

Struttura in acciaio inox 18/8. Imbottitura in poliuretano. Rivestimento in pelle.

Armchair

18/8 stainless steel frame. Polyurethane upholstery. Leather cover.

Petit fauteuil

Structure en acier inox 18/8. Rembourrage en polyuréthane. Revêtement en cuir.

Armlehnstuhl

Gestell aus Inox-Stahl 18/8. Polsterung aus Polyurethan. Bezug aus Leder.

Butaquita

Estructura de acero inox 18/8. Acolchado de poliuretano. Tapizado en piel.

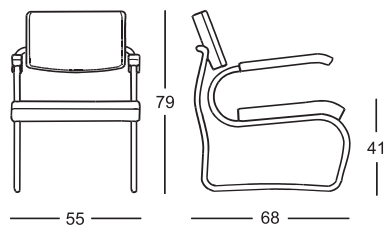

Susanna ⁸⁵²



Design

Gabriele Mucchi

1983

Poltroncina

Struttura portante in tubo di acciaio cromato, o nichelsatinato colore naturale o nero, oppure verniciato nero. Telaio porta-cuscini in acciaio verniciato nero, regolabile su due posizioni. Imbottitura cuscini in poliuretano/ fibra poliestere termolegata. Rivestimento cuscini sfilabile in stoffa o pelle. Nella versione con cuscini rivestiti in tessuto, i braccioli sono in pelle 95.

Armchair

Carrying frame in chromium-plated, or in natural or black nickel-satin finished, or black painted tubular steel. Adjustable two-position cushion support in black painted steel. Cushions upholstery in polyurethane/ heat-bound polyester fibre. Removable cushions cover in fabric or leather. The model with fabric covered cushions features the armrests covered with leather 95.

Petit fauteuil

Structure portante en tube d'acier chromé, ou nickel satiné, dans les finitions naturelle ou noire, ou verni noir. Châssis porte-coussins en acier verni noir, réglable sur deux positions. Rembourrage coussins en polyuréthane/fibre polyester liée à chaud. Revêtement coussins déhoussable en tissu ou cuir. Dans la version avec les coussins en tissu, les accoudoirs sont en cuir 95.

Armlehnstuhl

Gestell aus verchromtem oder schwarz-lackiertem Stahlrohr, oder mit naturfarben-oder schwarz-vernicheltem und mattedem Finish. Kissenträger-Rahmen aus schwarz lackiertem Stahl, in zwei Positionen verstellbar. Polsterung der Kissen aus Polyhurethan/ wärmegebundener Polyesterfaser. Abnehmbarer Kissen-Bezug aus Stoff oder Leder. Für die Version mit Stoff-bezogenen Kissen, sind die Armlehnen mit Leder 95.

Butaquita

Estructura tubular de acero cromado, o niquelado mate en los acabados natural o negro, o lacado negro. Bastidor porta-cojines de acero pintado de negro, regulable en dos posiciones. Acolchado de los cojines de poliuretano/ fibra poliéster termounida. Tapizado desenfundable de los cojines de tejido o de piel. Por el modelo con cojines tapizados de tejido, los apoyabrazos están tapizados de piel 95.

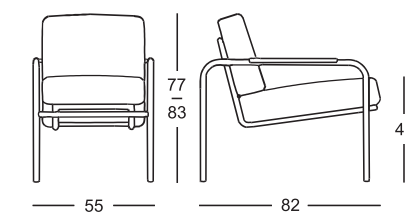

Struttura/Frame/Structure/Gestell/Estructura





Design

Francesca Lanzavecchia

2025

Poltrona/ bergere regolabile
Base girevole verniciata lucida nei colori talco, canapa, arancione, alga, amaranto, espresso e nero. Struttura in acciaio. Imbottitura schienale e braccioni in poliuretano schiumato autoestinguente con una percentuale di polioli di origine biologica e fibra in PET con contenuto post-consumo. Cuscino schienale in fibra soffiata di PET riciclato rivestita con tela in PET riciclato. Meccanismo sincronizzato integrato e regolabile, nascosto all'interno del sedile, che con-

sente di oscillare o bloccare lo schienale in qualsiasi posizione. Rivestimento amovibile in stoffa. Pouf. Base verniciata lucida nei colori talco, canapa, arancione, alga, amaranto, espresso e nero. Imbottitura in poliuretano schiumato autoestinguente con una percentuale di polioli di origine biologica. Rivestimento amovibile in stoffa.

Adjustable armchair/bergere
Glossy painted swivel base in the colours talc, hemp, orange, algae, amaranth, espresso and black. Steel frame, backrest and armrest padding in self-extinguishing polyurethane foam with a percentage of bio-based polyols/PET fibre including a percentage of post-consumer recycled material. Backrest cushion padding in recycled PET blown fibre covered with recycled PET canvas. Removable external cover in fabric. The armchair is equipped with an integrated,

adjustable synchronized mechanism, concealed inside the seat, which allows the backrest to swing or lock in any position. Pouf. Glossy painted base in the colours talc, hemp, orange, algae, amaranth, espresso and black. Self-extinguishing polyurethane foam padding with a percentage of bio-based polyols. Removable external cover in fabric.

Fauteuil/bergère réglable
Base pivotante vernie brillant dans les couleurs talc, chanvre, orange, algues, rouge amarante, espresso et noir. Structure en acier, rembourrage du dossier et des accoudoirs en mousse de polyuréthane auto-extinguible avec un pourcentage de polyols d'origine biologique/fibres de PET, dont une partie provient de matériaux recyclés post-consommation. Rembourrage du coussin du dossier en fibres de PET recyclées soufflées, recouvert d'une toile en PET

recyclé. Revêtement extérieur amovible en tissu. Le fauteuil est équipé d'un mécanisme synchronisé intégré et réglable, caché à l'intérieur de l'assise, qui permet au dossier de pivoter ou de se bloquer dans toutes les positions. Pouf. Base vernie brillant dans les couleurs talc, chanvre, orange, algues, rouge amarante, espresso et noir. Rembourrage en mousse de polyuréthane auto-extinguible avec un pourcentage de polyols d'origine biologique. Revêtement extérieur amovible en tissu.

Verstellbarer Sessel/Bergere
Glänzend lackierter Drehfuß in den Farben Talkum, Hanf, Orange, Algen, Amaranth, Espresso und Schwarz. Gestell aus Stahl, Polsterung von Rückenlehnen und Armlehnen aus selbstlöschendem Polyurethanschaum mit einem Anteil an Polyölen biologischen Ursprungs bzw. aus PET-Fasern mit einem Anteil an Post-Consumer-Recyclingmaterial. Polsterung des Rückenrüssens aus geblasener recycelter PET-Faser, die mit einem Bezug aus recyceltem PET-Gewebe ummantelt ist.

Abnehmbarer Außenbezug aus Stoff. Der Sessel ist mit einer integrierten, verstellbaren Synchronmechanismus ausgestattet, die in der Sitzfläche verborgen ist und das Schwenken oder Arretieren der Rückenlehne in jeder Position ermöglicht. Hocker. Glänzend lackierter Fuß in den Farben Talkum, Hanf, Orange, Algen, Amaranth, Espresso und Schwarz. Polsterung aus selbstverlöschendem Polyurethanschaum mit einem Anteil an Polyölen biologischen Ursprungs. Abnehmbarer Außenbezug aus Stoff.

Sillón/ bergere regulable
Base giratoria pintada brillante en los colores talco, cáñamo, naranja, alga, granate, espresso y negro. Armazón de acero, respaldo y apoyabrazos acolchados con espuma de poliuretano autoextinguible con un porcentaje de polioles de origen biológico/fibra de PET con un porcentaje de material reciclado postconsumo. Cojín de respaldo acolchado con fibra de PET reciclada soplada, revestida con lona/tela de PET reciclada. Tapizado exterior desenfundable de tejido. El

sillón está equipado con un mecanismo sincronizado integrado y regulable, oculto en el interior del asiento, que permite bascular o bloquear el respaldo en cualquier posición. Puf. Base pintada brillante en los colores talco, cáñamo, naranja, alga, granate, espresso y negro. Acolchado de espuma de poliuretano autoextinguible con un porcentaje de polioles de origen biológico. Tapizado exterior desenfundable de tejido.

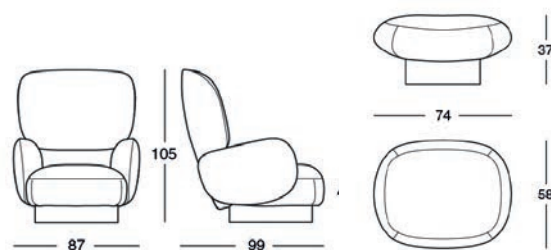

Struttura/Frame/Structure/Gestell/Estructura





Design

Christian Woo

2025

Pouf

Struttura in MDF impiallacciata in frassino laccato poro aperto colore talco, caramello, alga, amaranto e nero. Imbottitura sedile in poliuretano ottenuto da utilizzo di polioli con una percentuale a base vegetale. Rivestimento amovibile in stoffa o pelle.

Pouf

MDF structure veneered with open-pore lacquered ash in talc, caramel, algae, amaranth and black. Seat padding in polyurethane obtained from the use of vegetable-based polyols with a certain percentage. Removable fabric or leather cover.

Pouf

Structure en MDF plaquée en frêne laqué pore ouvert dans les couleurs talc, caramel, algues, amarante et noir. Rembourrage de l'assise en polyuréthane obtenu par l'utilisation de polyols d'origine végétale avec une pourcentage. Revêtement amovible en tissu ou cuir.

Hocker

MDF-Gestell, offenporig lackierter Esche furniert in den Farben Talkum, Karamell, Algen, Amaranrot und schwarz. Sitzpolsterung aus Polyurethan, mit Verwendung von Polyolen mit einem Anteil auf pflanzlicher Basis. Abnehmbarer Bezug aus Stoff oder Leder.

Púf

Estructura en MDF chapada en fresno lacado a poro abierto en colores talco, caramelo, alga, granate y negro. Acolchado del asiento en poliuretano obtenido con la utilización de poliols con una porcentaje de origen vegetal. Tapizado desenfundable en tejido o piel.

267

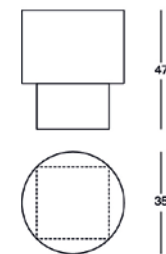

268

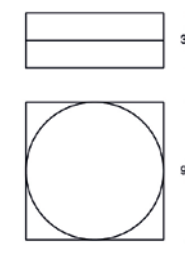

Struttura/Frame/Structure/Gestell/Estructura



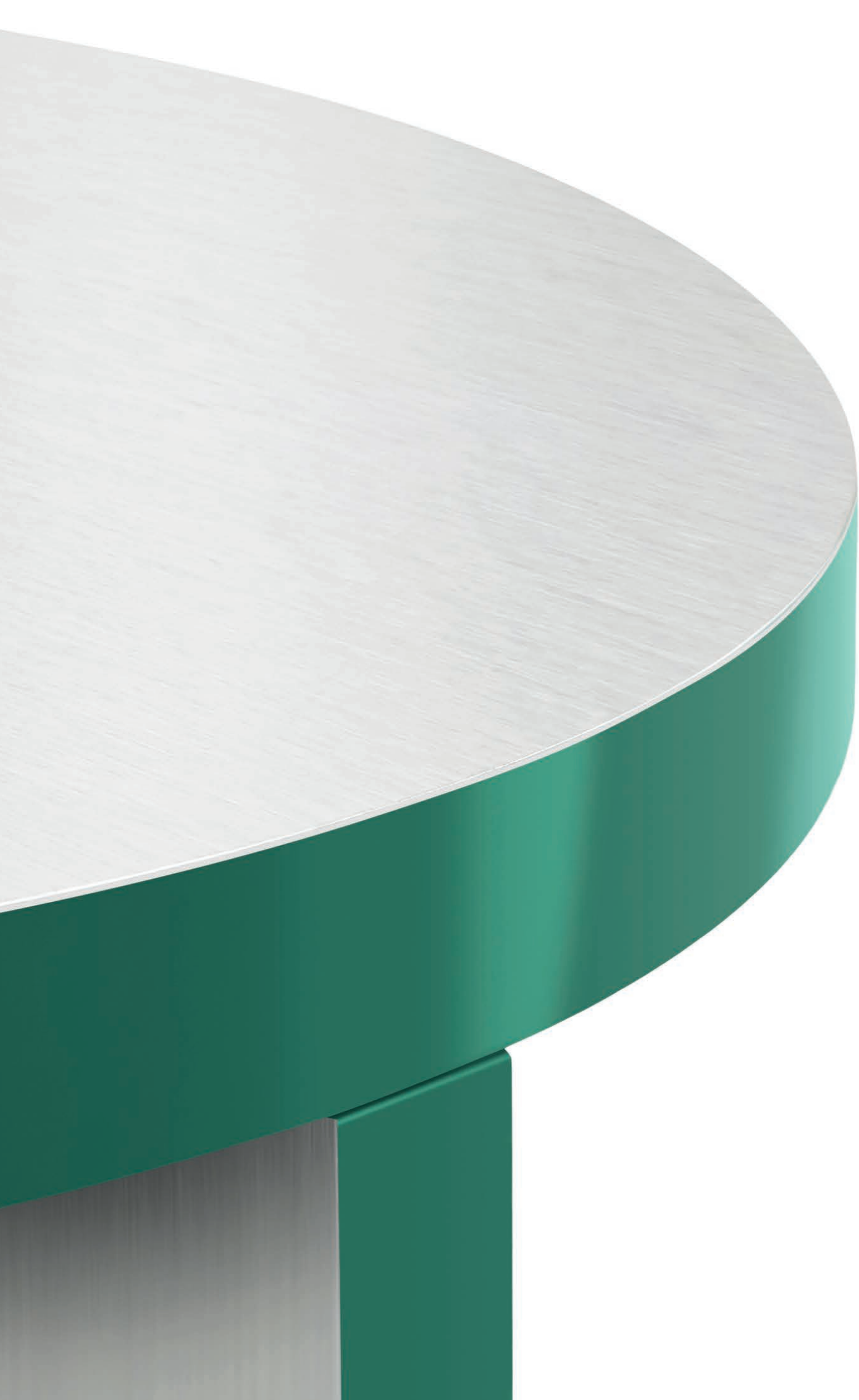

Small Tables, Nightstands

Tavolini,
Comodini
Petites tables,
Tables de chevet
Couchtische,
Nachttische
Mesitas, Mesitas
de noche

100–125



Design

Monica Armani

2026

Tavolino

Base e piano in cemento verniciato nei colori canapa, alga, amaranto ed espresso. Il piano è caratterizzato da un decoro testurizzato tridimensionale.

Coffee table

Concrete base and top, painted in the colours hemp, algae, amaranth and espresso. The top features a three-dimensional textured finish

Petite table

Piètement et plateau en ciment verni dans les couleurs chanvre, algue, rouge amarante et espresso. Le plateau se distingue par un motif texturé en relief.

Beistelltisch

Gestell und Tischplatte aus Zement, lackiert in den Farben Hanf, Algen, Amarantröt und Espresso. Die Tischplatte zeichnet sich durch ein dreidimensionales Strukturmuster aus.

Mesita

Base y plano de cemento pintado en los colores cáñamo, alga, granate y espresso. El plano presenta un relieve tridimensional.

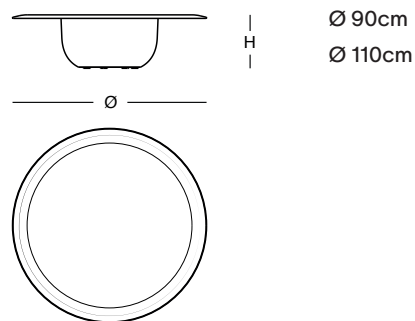

Struttura/Frame/Structure/Gestell/Estructura

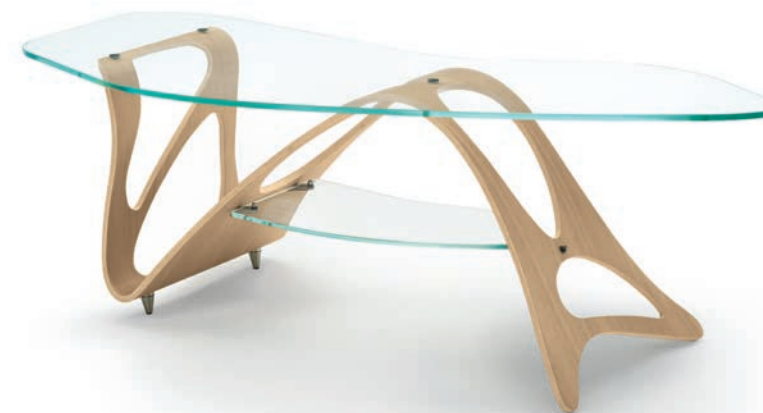

Design

Carlo Mollino

1949

Tavolino

Struttura in multistrati curvato, in rovere naturale o tinto nero; verniciatura con finitura a cera. La struttura è fissata al piano tramite bussole passanti. Piano superiore in cristallo temperato, piano inferiore in cristallo temperato, entrambi rispettivamente in cristallo extra-chiaro per la versione in rovere naturale o in cristallo fumè grigio per la versione in rovere tinto nero.

Small table

Bent plywood frame in natural or black varnished oak; wax-finished varnish. The frame is attached to the top with an internally threaded screw. Top shelf in tempered plate glass; bottom shelf in tempered plate glass, both either extra-clear, matching the frames in natural oak or in smoky grey plate glass, matching the black varnished oak frame.

Petite table

Structure en contreplaqué courbé, plaqué en rouvre naturel ou teinté noir; verni finition cirée. La structure est fixée au plateau avec des traversées. Plateau supérieur en verre trempé. Tablette inférieure en verre trempé, les deux respectivement en verre extra-clair pour la version en rouvre naturel ou en verre gris fumé pour la version en rouvre teinté noir.

Couchtisch

Gestell aus gebogenem Schichtholz, mit naturfarbener oder schwarz lackierter Eiche furniert; Lackierung mit Wachs-Endbehandlung. Das Gestell ist mittels Durchführungsbuchsen am Gestell verbunden. Obere Platte aus gehärtetem Kristallglas; untere Platte aus gehärtetem Kristallglas, beide entweder extra-klar für die Version aus naturfarbener Eiche oder grau rauchfarben für die Version aus schwarz lackierter Eiche.

Mesita

Estructura en madera contrachapada curvada, aplacada en roble natural o teñido negro; pintura con acabado de cera. La estructura se fija al sobre con brújulas que pasan a través. Superficie superior en cristal templado; superficie inferior en cristal templado, ambos respectivamente en cristal extra-claro para la versión de roble natural o en cristal gris humo para la versión de roble teñido negro.

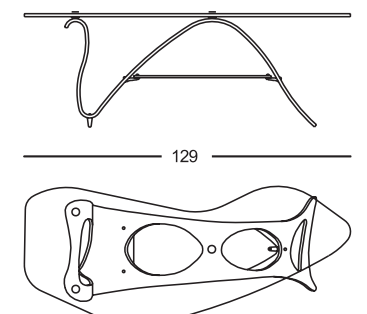

Struttura/Frame/Structure/Gestell/Estructura

Rovere naturale/
Natural oakwood/
Rouvre naturel/
Naturfarbene
Eiche/Roble
natural



Rovere tinto nero/
Black varnished
oak/Rouvre teinté
noir/Schwarz-
gebeizte Eiche/
Roble teñido
negro



Piano/Top/Plateau/Platte/Sobre

Cristallo extra-
chiaro/Extra-clear
plate glass/Verre
extra-clair/Extra-
klares Kristallglas/
Cristal extra-claro



Cristallo fumè
grigio/Smoky
grey plate glass/
Verre gris fumé/
Rauchfarbenes
Kristallglas/Cristal
gris humo



Basello ⁶³⁸



Design

Achille Castiglioni

1987

Tavolino a doppia altezza con ripiani rotanti
Struttura in medium density fiberboard, verniciatura gofrata antigraffio nei colori talco, canapa, amaranto, espresso o nero. Snodo in acciaio verniciato nero nelle versioni canapa, amaranto, espresso o nera, oppure talco nella versione talco.

Double height small table with rotating shelves
Frame in medium density fiberboard finished with scratch resistant embossing in the shades talc, hemp, amaranth, espresso or black. Steel articulated joint in the shade black for the models hemp, amaranth, espresso, black or in the shade talc for the talc model.

Petite table à deux hauteurs à étagères pivotantes
Structure en medium density fiberboard, vernie antirayures dans les couleurs talc, chanvre, rouge amarante, espresso ou noire. Articulation en acier verni noir dans les versions chanvre, rouge amarante, espresso, noire, ou verni talc pour la version talc.

Zweiteiliger verstellbarer mit Drehregalen
Gestell aus Medium Density Fiberboard mit Anti-Kratzer-Lackierung, in den Farben in den Farben Talkum, Hanf, Amaranrot, Espresso oder schwarz. Verbindungsstück aus schwarz-lackiertem Stahl für die Modelle in den Farben Hanf, Amaranrot, Espresso, schwarz, oder Talkum-lackiert für die Talkum-Version.

Mesita de doble altura con estantes giratorios
Estructura en medium density fiberboard, laca en relieve anti-rasguño en los colores talco, cañamo, granate, espresso o negro. Articulación de acero pintado negro por las versiones en cañamo, granate, espresso, negro o talco por la versión en talco.

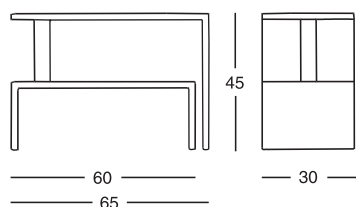

Verniciatura gofrata/Embossed paint/Vernissage gaufré/Gaufrierte Lackierung/Lacadura anti-rasguño



Snodo/Articulated joint/Articulation/Verbindungsstück/Articulación



Carlino CM ³³⁵

* Vedi nota a fine catalogo
* See note at the end of the catalogue
* Voir la note en fin de catalogue
* Siehe Hinweis am Ende des Katalogs
* Ver nota al final del catálogo



Design

Carlo Mollino

1938

Contenitore di servizio
Struttura e cassetto in legno verniciato nei colori talco e nero. Pianetto d'appoggio in cristallo nei medesimi colori. Prevede il fissaggio a parete.

Service storage unit
Frame and drawer in painted wood, in the shades talc and black. Plate glass top in the same colours. It must be fastened to wall.

Petit meuble d'appoint
Structure et tiroir en bois peint couleur talc et noir. Tablette d'appui en verre dans les mêmes couleurs. Prevede il fissaggio a parete.

Service-Behälter
Gestell und Schublade aus lackiertem Holz, in den Farben Talkum und schwarz. Platte aus Kristallglas in den gleichen Farben. Für die Wandmontage vorgesehen.

Mueble de apoyo
Estructura y cajón de madera lacada en los colores talco y negro. Superficie de apoyo en cristal en los mismos colores. Prevede il fissaggio a parete.

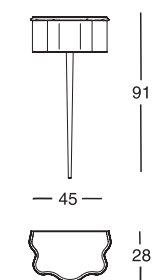

Struttura/Frame/Structure/Gestell/Estructura



Cumano 630



Design

Achille Castiglioni

1978

Tavolino pieghevole
Struttura e piano in acciaio verniciato talco, amaranto, verde prato o nero. Giunto scorrevole in ABS. E' dotato di un gancio per appenderlo a parete.

Folding table
Steel frame and top. Colours: talc, amaranth, grass green or black. ABS sliding joint. It is equipped with a hook for hanging.

Petite table pliante
Structure et plateau en acier, dans les couleurs talc, rouge amarante, vert pré ou noire. Joint coulissant en ABS. Il est équipé d'un crochet pour l'accrocher au mur.

Klapptisch
Gestell und Platte aus Stahl in den Farben Talkum, Amaranrot, grasgrün, oder schwarz. Verschiebbares Gelenk aus ABS. Er ist mit einem Haken zum Aufhängen an der Wand ausgestattet.

Mesita plegable
Estructura y sobre de acero, en los colores: talco, granate, verde prado o negro. Anilla corredera en ABS. Esta equipado de un gancho para colgarlo a la pared.

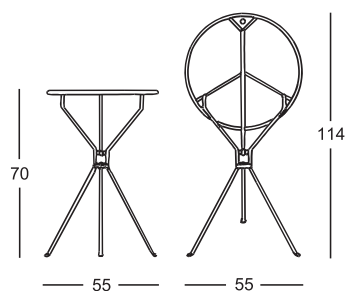

Struttura/Frame/Structure/Gestell/Estructura



Girò 635



Design

Anna Deplano

1997-1999

Tavolino con rotelle
Struttura in acciaio verniciato, colore alluminio. Pianetti in laminato plastico stratificato, colore bianco.

Castor-mounted table
Aluminium- painted steel frame. Shelves in layered plastic laminate in white.

Petite table avec roulettes
Structure en acier verni, couleur aluminium. Plateaux en laminé plastique stratifié, couleur blanc.

Tischchen mit Rollen
Gestell aus alufarben lackiertem Stahl. Platten aus massivem weißen Plastiklaminat.

Mesita con ruedas
Estructura de acero pintado de color aluminio. Repisas de laminado plástico estratificado, de color blanco.

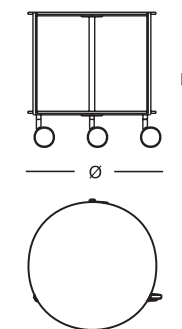

Ø 50 H 53,5 cm
Ø 75 H 37 cm
Ø 110 H 37 cm

Graphium 681/682

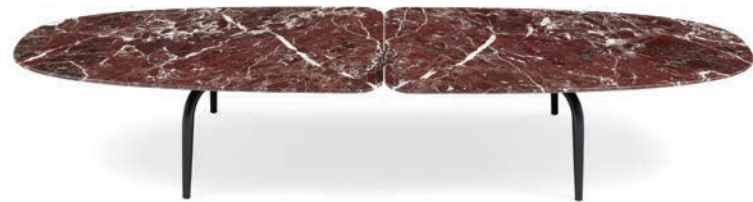

Design

Garcia Cumini

2019

Tavolini

Struttura in acciaio verniciato colore nero. Piani in marmo Calacatta grigio, in marmo rosso Lepanto o in marmo Sahara Noir con verniciatura protettiva antimacchia, in poliestere trasparente opaco.

Small tables

Black varnished steel frame. Tops available either in grey Calacatta marble, in red Lepanto marble or in Sahara Noir marble with stain-resistant protective varnish, in clear matt polyester.

Petites tables

Structure en acier verni noir. Plateaux en marbre Calacatta gris, en marbre rouge Lepanto ou en marbre Sahara Noir avec peinture de protection anti-taches en polyester transparent opaque.

Couchtische

Gestell aus schwarz lackiertem Stahl. Platten aus graufarbenem Calacatta Marmor, oder aus rotem Lepanto Marmor oder aus Sahara Noir Marmor mit Fleckenschutz Lackierung aus klarem mattem Polyester.

Mesitas

Estructura en acero pintado negro. Sobres de mármol Calacatta gris, de mármol Lepanto rojo o de mármol Sahara Noir con laca de protección antimancha en poliéster opaco transparente.

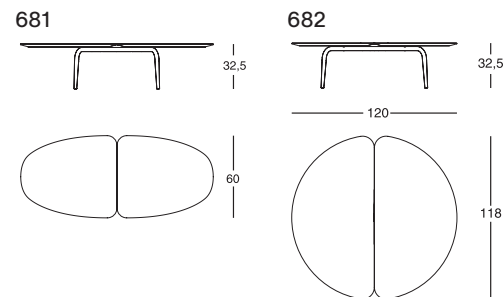

140x60 cm
200x60 cm
120x118 cm

Piano/Top/Plateau/Platte/Sobre

Marmo Calacatta/
Calacatta marble/
Marbre Calacatta/
Calacatta Marmor/
Mármol Calacatta

Marmo Lepanto/
Lepanto marble/
Marbre Lepanto/
Lepanto Marmor/
Mármol Lepanto

Marmo Sahara
Noir/Sahara
Noir marble/
Marbre Sahara
Noir/Sahara Noir
Marmor/Mármol
Sahara Noir



Low Bol 658/666

NEW DIMENSION



Design

Zaven

2025-2026

Tavolino

Struttura in poliuretano rigido laccatura lucida o opaca nei colori talco, canapa, caramello, alga, amaranto, espresso.

Small table

Hard polyurethane frame, matt or glossy lacquered in the shades talc, hemp, caramel, algae, amaranth, espresso.

Petite table

Structure en polyuréthane rigide, laquée brillant ou mat dans les couleurs talc, chanvre, caramel, algues, amarante, espresso.

Beistelltisch

Estructura en poliuretano rígido lacado brillante o mate en los colores talco, cáñamo, caramelo, alga, granate, espresso.

Mesita

Gestell aus hartem Polyurethan, glänzend oder matt lackiert in den Farben Talkum, Hanf, Karamell, Algen, Amaranrot, Espresso.

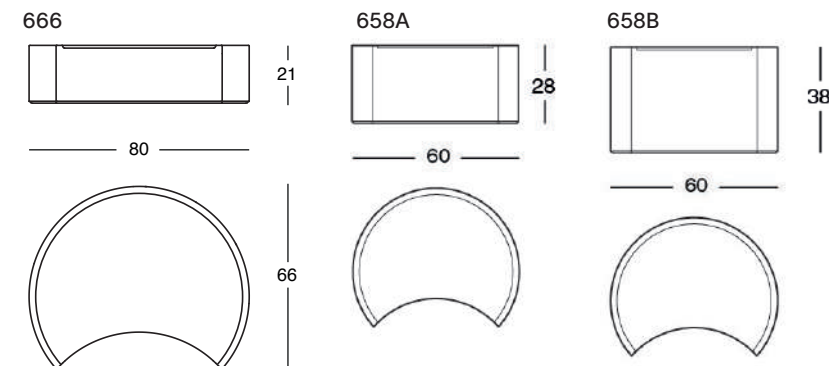

Struttura/Frame/Structure/Gestell/Estructura

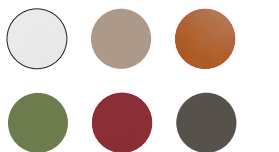

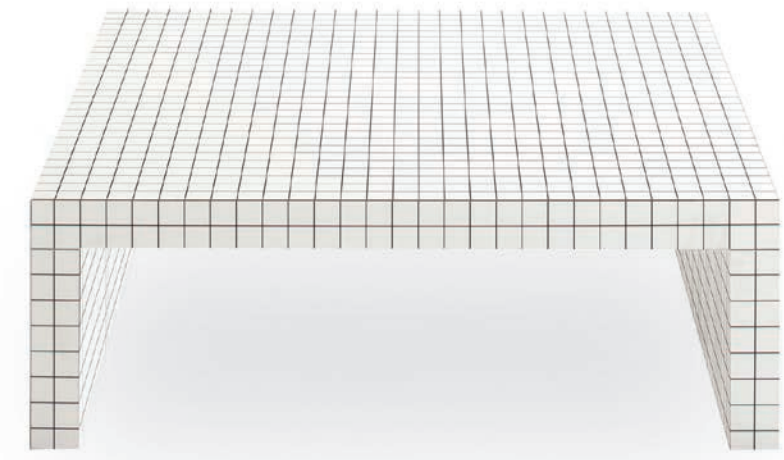

Design

Emaf Progetti

2005

Comodino con cassetto
Struttura in acciaio verniciato colore grafite. Maniglia in alluminio verniciato colore grafite. Cassetto in medium density fiberboard impiallacciato in frassino tinto rovere, tinto grigio o talco.

Night table with drawer
Graphite painted steel frame. Handle in graphite painted aluminium. Drawer in medium density fiberboard veneered with oak- grey or talc-stained ash.

Table de chevet avec tiroir
Structure en acier verni couleur graphite. Poignée en aluminium verni couleur graphite. Tiroir en medium density fiberboard, contreplaqué en frêne teinté rouvre, gris ou talc.

Nachttisch mit Schublade
Gestell aus Graphit lackiertem Stahl. Griff aus Graphit lackiertem Aluminium. Schublade aus medium density fiberboard mit Eschenholzurnier in Eiche, grau oder talkfarben.

Mesita de noche con cajón
Estructura de acero pintado grafito. Manecilla de aluminio pintado color grafito. Cajón de medium density fiberboard enchapado de fresno teñido roble, gris o talco.

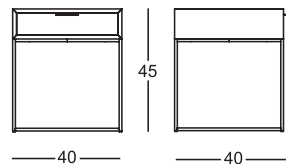

Cassetto/Drawer/Tiroir /Schublade/Cajón

Frassino tinto grigio/
Grey varnished ash/
Frêne teinté gris/
Gru-gebeizte
Esche/Fresno
teñido gris



Frassino tinto talco/
Talc varnished ash/
Frêne teinté talc/
Talkum-gebeizte
Esche/Fresno
teñido talco



Frassino tinto rovere/
Oak varnished ash/
Frêne teinté rouvre/
Eiche gebeizte
Esche/Fresno
teñido roble



Design

Superstudio

1969-1972

Tavolino
Struttura in legno tamburato placcato laminato Print, colore bianco, a stampa digitale a quadretti con interasse di 3 cm.

Coffee table
Honeycomb core structure coated with white Print laminate, digitally printed with black squares at 3 cm spacing.

Petite table
Structure en panneau alvéolaire plaqué en laminé Print, couleur blanche, imprimé en digital à carrés noirs avec entraxe de 3 cm.

Beistelltisch
Gestell aus Sperrholz mit weißem Print Laminat belegt. Digitaldruck mit kariertem Muster, Linienabstand 3 cm.

Mesita
Estructura de madera aplacada con laminado Print, color blanco, a impresión digital en cuadrillos negros de 3 cm.

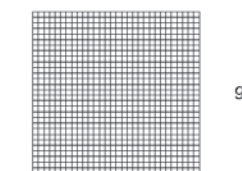
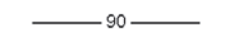

Quaderna Small Table ⁷¹⁰

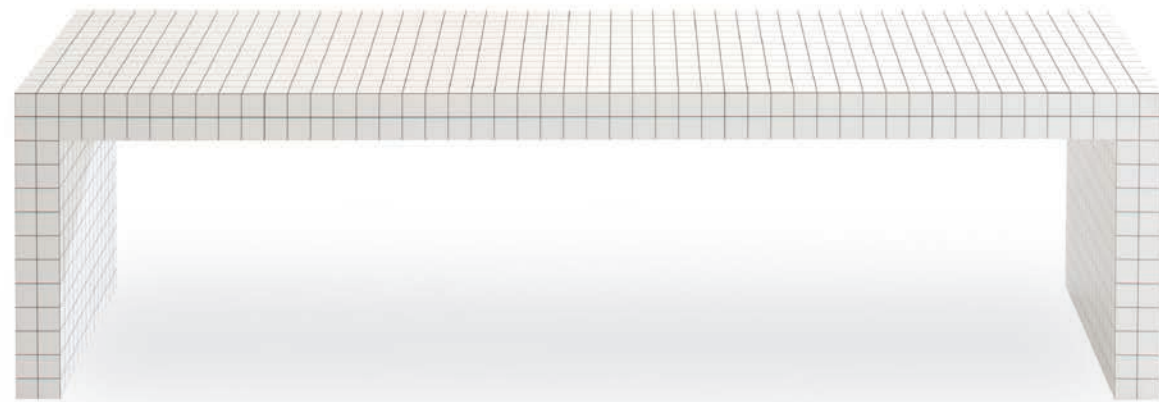

Design

Superstudio

1969-1972

Tavolino

Struttura in legno tamburato placcato laminato Print, colore bianco, a stampa digitale a quadretti con interasse di 3 cm.

Small table

Honeycomb core structure coated with white Print laminate, digitally printed with black squares at 3 cm spacing.

Petite table

Structure en panneau alvéolaire plaqué en laminé Print, couleur blanche, imprimé en digital à carrés noirs avec entraxe de 3 cm.

Beistelltisch

Gestell aus Sperrholz mit weißem Print Laminat belegt. Digitaldruck mit kariertem Muster, Linienabstand 3 cm.

Mesita

Estructura de madera aplacada con laminado Print, color blanco, a impresión digital en cuadrillos negros de 3 cm.

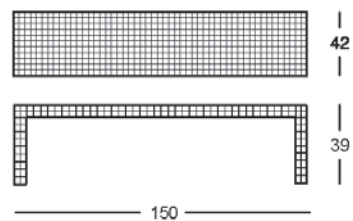

Servomuto ³⁶⁰



Design

Achille Castiglioni

della serie Servi di Achille & Pier Giacomo Castiglioni 1974

Tavolino

Base in polipropilene e asta in acciaio verniciato colore talco o nero. Pianetto in laminato plastico stratificato, colore bianco/nero, reversibile.

Small table

Base in polypropylene and steel rod painted, colour talc or black. Top in reversible black/white plastic laminate.

Petite table

Base en polypropylène et tige en acier peint en couleur talc ou noir. Plateau en laminé plastique stratifié, couleur blanc/noir, réversible.

Beistelltisch

Fuß aus Polypropylen und Stange aus lackiertem Stahl, Farbe Talkum oder schwarz. Tischplatte aus massivem Plastiklaminat, in den Farben weiß/schwarz, umkehrbar.

Mesita

Base de polipropileno y soporte de acero pintado, color talco o negro. Repisa de laminado plástico estratificado, en los colores blanco/negro, reversible.

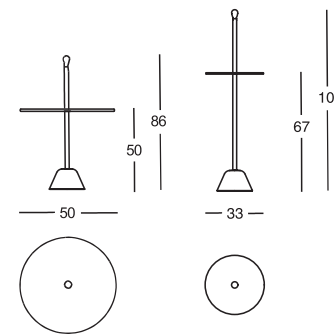

Struttura/Frame/Structure/Gestell/
Estructura



Pianetti/Shelves/Plateaux/Platten/
Repisas



Slice Me Nice 601

NEW PRODUCT

Ta.Ba.Ce. 700



Design

Studiopepe

2026

Tavolino

Piano e gambe in MDF placcati in laminato Fenix® colore argento. Bordi laccati lucidi nei colori arancio, verde prato, amaranto, espresso e nero.

Small table

MDF top and legs, coated with silver Fenix® laminate. Glossy painted edges in the colours orange, grass green, amaranth, espresso and black.

Petite table

Plateau et pieds d'épaisseur, recouverts en laminé Fenix® couleur argent. Bords vernis brillants dans les couleurs orange, vert pré, rouge amarante, espresso et noir.

Beistelltisch

Tischplatte und Beine aus MDF, Stärke 42 mm, beschichtet mit silberfarbenen Fenix®-Laminat. Glänzend lackierte Kanten in den Farben Orange, Grasgrün, Amaranth, Espresso und Schwarz.

Mesita

Plano y patas de MDF, revestidos con laminado Fenix® en color plata. Bordos pintados brillantes en los colores naranja, verde prado, granate, espresso y negro.

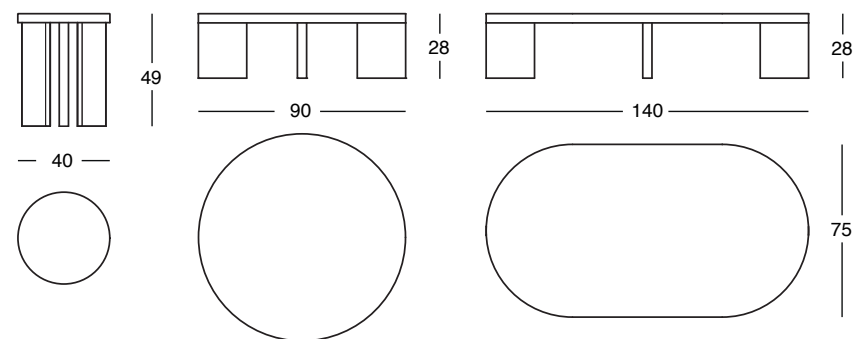

Design

Philippe Malouin

2024

IN/OUT

Tavolino

Struttura in gres fine porcellanato antigelivo per esterni. Smaltatura lucida nei colori: talco, canapa, caramello, arancione, espresso.

Small table

Freeze-resistant frame in fine porcelainized grès for outdoor use. Polished enamelling in the colours: talc, hemp, caramel, orange, espresso.

Petite table

Structure en grès fin émaillé résistante au gel pour externes. Émaillage poli dans les couleurs: talc, chanvre, caramel, orange, espresso.

Beistelltisch

Gestell aus frostfestem und wetterbeständigem Feinsteinzeug. Polierte Glasur in den Farben: Talkum, Hanf, Karamell, Orange, Espresso.

Mesita

Estructura de gres fino porcelánico antihielo para uso exterior. Esmaltado brillante en los colores: talco, cáñamo, caramelo, naranja, espresso.

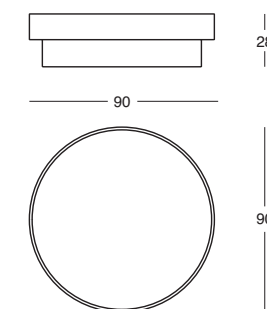



Design

Gabriele Rosa

2017

Comodino con cassetto
Struttura e piano in acciaio verniciato colore talco, nero o grafite. Piano e vano portaoggetti in cuoio pigmentato 90. Il vano è accessibile mediante apertura a ribalta.

Nightstand with drawer
Top and frame in talc, black or graphite painted steel. Top and storage space in cowhide pigmentato 90. The storage is accessed by a dropleaf opening.

Table de chevet avec tiroir
Structure et plateau en acier verni couleur talc, noire ou graphite. Plateau et élément porte-objets en cuir sellier pigmentato 90. L'élément est accessible par une ouverture basculante.

Nachtisch mit Schublade
Gestell und Platte aus Talkum-, schwarz- oder graphitfarben- lackiertem Stahl. Platte und Ablagefach aus Kernleder pigmentato 90. Das Ablagefach ist mit Kippöffnung versehen.

Mesita de noche con cajón
Estructura y sobre de acero pintado de color talco, negro o grafito. Sobre y compartimento portaobjetos de cuero pigmentato 90. Se puede acceder al compartimento mediante apertura abatible.

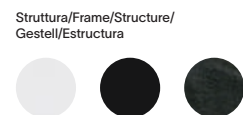
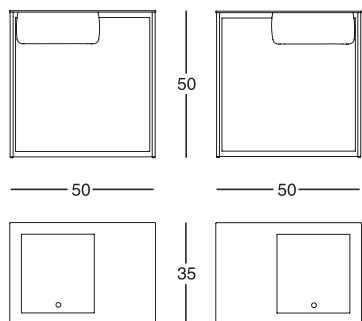

Design

Prospero Rasulo

2001

Tavolino-portaoggetti
Coni in poliuretano rigido, asta di sostegno in acciaio, laccatura lucida nei colori talco, cera, canapa, caramello, arancione, amaranto, verde prato, alga, espresso o nero.

Small table/stand
Stiff polyurethane cones, steel stem, glossy lacquer in the colours talc, wax, hemp, caramel, orange, amaranth, grass green, algae, espresso or black.

Table basse/porte-objets
Cônes en polyuréthane rigide, tige de soutien en acier, laquage brillant dans les couleurs talc, cire, chanvre, caramel, orange, rouge amarante, vert pré, algues, espresso ou noir.

Tischchen/Ablage
Kegel aus steifem Polyurethan, Trägerstange aus Stahl mit poliertem Glanzlack in den Farben Talkum, Wachs, Hanf, Karamell, Orange, Amaranth, grasgrün, Algen, Espresso oder schwarz.

Mesita/porta objetos
Conos de poliuretano rígido, asta central de acero, lacados brillante en los colores talco, cera, cañamo, naranja, caramelo, granate, verde prado, alga, espresso o negro.

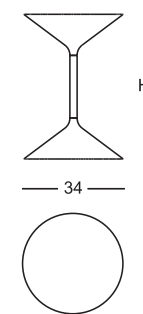

Struttura/Frame/Structure/Gestell/Estructura





Design

Prospero Rasulo

2006

IN/OUT

Tavolino

Struttura in gres fine porcellanato antigelivo per esterni, con doppia smaltatura manuale a spessore controllato, cotto a 1250°C con un ciclo di lavorazione di 36 ore, colore verde-giallo.

Occasional table

Freeze resistant frame in fine porcelainized grès for outdoors use with thickness controlled two-layering applied by hand and baked at 1250°C with a 36-hour processing cycle, colour green-yellow..

Petite table

Structure en grès fin émaillé résistante au gel pour externes, avec double émaillage manuel à épaisseur contrôlée, cuit à 1250°C en appliquant un cycle d'oeuvre de 36 heures, couleur vert-jaune.

Couchtisch

Gestell aus frostfestem und wetter-beständigem Feinsteinzeug, doppelte, dickenkontrollierte Handglasur, über 36 Stunden bei 1250 °C gebrannt, Farbe grün-gelb.

Mesita

Estructura de gres fino porcelánico antihielo para uso exterior, con doble capa de esmalte a mano de espesor controlado, cocido a 1250°C con un ciclo de elaboración de 36 horas, color verde-amarillo.

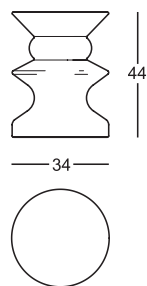

Design

Todd Bracher

2005

Tavolino

Struttura in polipropilene, laccatura lucida nei colori talco, cera, canapa, caramello, arancione, amaranto, verde prato, espresso o nero.

Small table

Polypropylene frame and glossy lacquer finish in the colours talc, wax, hemp, caramel, orange, amaranth, grass green, espresso or black.

Petite table

Structure en polypropylène, laquage brillant dans les couleurs talc, cire, chanvre, caramel, orange, rouge amarante, vert pré, espresso ou noir.

Tischchen

Gestell aus Polypropylen, mit poliertem Glanzlack in den Farben Talkum, Wachs, Hanf, Karamell, Orange, amarantrot, grasgrün, Espresso oder schwarz.

Mesita

Estructura de polipropileno, lacado brillante en los colores talco, cera, cañamo, naranja, caramelo, granate, verde prado, espresso o negro.

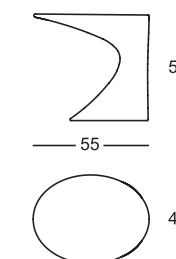

Struttura/Frame/Structure/Gestell/Estructura





Design

Salvatore Indriolo

2012

Tavolino

Struttura in poliuretano rigido. Piano in multistrato placcato alluminio. Verniciatura nei colori talco, amaranto o nero. Il piano superiore ruotando a 360° permette l'accesso ad un vano portaoggetti sottostante.

Small table

Stiff polyurethane frame. Aluminum-covered plywood top. Varnish in talc, amaranth or black. Organizer compartment revealed by rotating tabletop 360°.

Petite table

Structure en polyuréthane rigide. Plateau en multicouche plaqué aluminium. Peinture en talc, rouge amarante ou noire. Le plateau supérieur tourne à 360° et permet ainsi d'accéder à un espace porte-objets situé dessous.

Couchtisch

Gestell aus steifem Polyurethan. Furnierholzplatte mit Aluminium beschichtet. Lackierung in den Farben Talkum, amaranthrot oder schwarz. Die Platte lässt sich über einem darunterliegenden Staufach um 360° drehen.

Mesita

Estructura de poliuretano rígido. Sobre en multicapa chapado de aluminio. Lacado en color talco, granate o negro. Girando 360° el sobre superior se accede a un compartimento portaobjetos inferior.

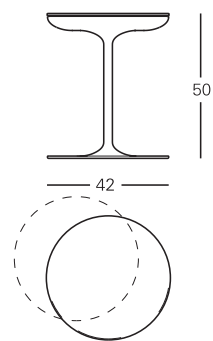

Struttura/Frame/Structure/Gestell/
Estructura



Design

Bertrand Lejoly

2022

Tavolini

Struttura in acciaio verniciato colore nero opaco. Piani in lamiera di acciaio rivestiti in cuoio pigmentato 90 nei colori gold, nero, antracite e fango in abbinamento al piede in faggio laccato colore nero lucido, oppure piani in marmo bianco di Carrara o verde Alpi, in abbinamento rispettivamente al piede in faggio laccato colore bianco lucido RAL 9010 o verde lucido RAL 6012.

Coffee tables

Matt black varnished steel frame. Steel sheet tops, covered with cowhide pigmentato 90 in the shades gold, black, anthracite and mud matching the foot in glossy black painted beech; or tops made of white Carrara or green Alpi marbles, matching the foot respectively in glossy white green RAL 9010 painted or glossy green RAL 6012 painted beech.

Petites tables

Structure en acier verni noir mat. Plateaux en tôle d'acier recouverts de cuir sellier pigmentato 90 dans les couleurs gold, noir, anthracite et boue en combinaison avec le pied en hêtre laqué noir brillant, ou plateaux en marbre blanc de Carrare ou Alpi vert, en combinaison respectivement avec le pied en hêtre laqué blanc brillant RAL 9010 ou vert brillant RAL 6012.

Beistelltische

Stahlgestell schwarz matt lackiert. Platten aus Stahlblech, bezogen mit Kernleder pigmentato 90 in den Farben gold, schwarz, anthrazit und Schlamm, passend zum Fuß aus glänzend schwarz lackiertem Eschenholz; oder Platten aus weißem Carrara-Marmor oder grünem Alpi-Marmor, passend zum Fuß bzw. aus glänzend weiß RAL 9010 – oder glänzend grün RAL 6012 lackiertem Eschenholz.

Mesitas

Estructura en acero pintado en negro mate. Sobres en chapa de acero recubiertas de cuero pigmentato 90 en los colores gold, negro, antracita y barro en combinación con el pie en haya lacada en negro brillante, o sobres en mármol blanco de Carrara o Alpi verde, en combinación respectivamente con el pie en haya lacada en blanco brillante RAL 9010 o verde brillante RAL 6012.

627

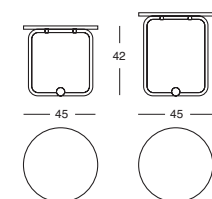

628

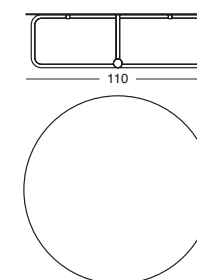

629

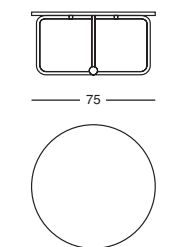

Piani/Tops/Plateaux/Platten/Sobres



Marmo di Carrara/
Carrara marble/
Marbre de
Carrare/Carrara
Marmor/Mármol
de Carrara



Marmo Alpi/Alpi
marble/Marbre
Alpi/Alpi Marmor/
Mármol Alpi

Tweed Mini 662



Design

Garcia Cumini

2021

Tavolini

Piano in legno placcato in rovere verniciato colore naturale, o a poro aperto colore nero, oppure placcato in noce Canaletto. Sotto piano verniciato colore nero. Gambe in tubolare di acciaio verniciato colore nero opaco.

Small tables

Top available either in natural painted oak veneered wood, or black painted with open pore, or in Canaletto walnut veneered wood. Black painted under-top. Legs in tubular stainless steel, matt black painted.

Petites tables

Plateau en bois plaqué en rovere verni couleur naturel, ou verni à pore ouvert de couleur noire, ou plaqué en noyer Canaletto. Le plateau au-dessous est verni couleur noire. Pieds en acier tubulaire vernis couleur noir mat.

Beistelltische

Holzplatte furniert mit naturfarben lackierter Eiche, oder schwarz lasiert, oder mit Nussbaum Canaletto. Schwarz lackierte Unterplatte. Beine aus mattem schwarz- lackierten Stahlrohr.

Mesitas

Superficie de madera chapado en roble barnizado natural, o pintado a poro abierto en color negro, o chapado en nogal Canaletto. La parte inferior del sobre es pintado de color negro. Patas en acero tubular pintado de color negro mate.

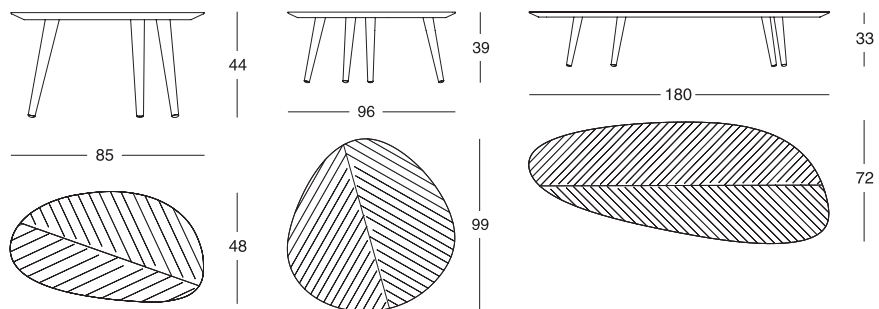

Piani/Tops/Plateaux/Platten/Sobres

Rovere naturale/
Natural oakwood/
Rouvre nature/
Naturfarbene
Eiche/Roble
natural

Rovere tinto nero/
Black varnished
oak/Rouvre teinté
noir/Schwarz-
gebeizte Eiche/
Roble teñido
negro

Noce Canaletto/
Canaletto walnut/
Noyer Canaletto/
Nussbaum
Canaletto/Nogal
Canaletto



Tweed Mini 664



Design

Garcia Cumini

2021

Tavolini

Piano in MDF spessore 30 mm, laccato opaco colore canapa, amaranto, espresso e nero. Gambe in tubolare di acciaio verniciato colore nero opaco.

Small tables

MDF top, thickness 30 mm, matt lacquered in the colours hemp, amaranth, espresso and black. Legs in tubular stainless steel, matt black painted.

Petites tables

Plateau en MDF, épaisseur 30 mm, verni mat dans les couleurs chanvre, rouge amarante, espresso et noir. Pieds en acier tubulaire vernis couleur noir mat.

Beistelltische

MDF-Platte, Stärke 30 mm, matt lackiert in den Farben Hanf, Amaranth, Espresso und schwarz. Beine aus matt schwarz- lackiertem Stahlrohr.

Mesitas

Sobre de MDF, espesor 30 mm, lacado mate en los colores cáñamo, granate, espresso y negro. Patas en acero tubular pintado de color negro mate.

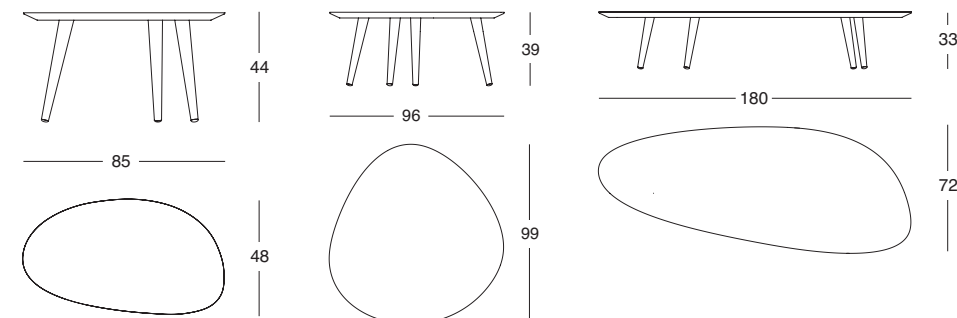

Piani/Tops/Plateaux/Platten/Sobres



Z24 Nightstand ⁷²⁸



Design

Muller Van Severen

2024

Comodino
Struttura in MDF e legno listellare, laccatura opaca nei colori talco, cera, canapa, caramello, arancione, amaranto, verde prato, alga, espresso e nero. Ripiano interno regolabile in cristallo temperato.

Nightstand
Frame in MDF and blockboard wood, matt lacquered in the colours talc, wax, hemp, caramel, orange, amaranth, grass green, algae, espresso and black. Adjustable internal shelf in tempered plate glass.

Table de chevet
Structure en MDF et bois à lamelles, laquée mat dans les couleurs talc, cire, chanvre, caramel, orange, rouge amarante, vert pré, algues, espresso et noir. Plateau intérieure réglable en verre trempé.

Nachtisch
Gestell aus MDF und Lattenholz matt lackiert in den Farben Talkum, Wachs, Hanf, Karamell, Orange, Amarantröt, grasgrün, Algen, Espresso und schwarz. Verstellbares inneres Regal aus gehärtetem Kristallglas.

Mesita de noche
Estructura de MDF y listones de madera, lacada mate en los colores talco, cera, cáñamo, caramelo, naranja, granate, verde prato, alga, espresso y negro. Estante interior regulable de cristal templado.

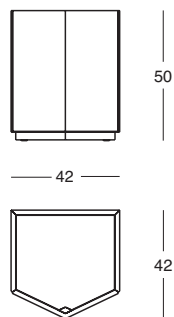

Struttura/Frame/Structure/Gestell/Estructura



Zavolo Coffee Table ^{790/791}



Design

Zaven

2024

Tavolini
Struttura in MDF, laccatura opaca nei colori talco, cera, canapa, caramello, arancione, amaranto, verde prato, alga, espresso e nero.

Small tables
MDF frame, matt lacquered in the colours talc, wax, hemp, caramel, orange, amaranth, grass green, algae, espresso and black.

Petites tables
Structure en MDF, laquée mat dans les couleurs talc, cire, chanvre, caramel, orange, rouge amarante, vert pré, algues, espresso et noir.

Beistelltische
Gestell aus MDF, matt lackiert in den Farben Talkum, Wachs, Hanf, Karamell, Orange, Amarantröt, grasgrün, Algen, Espresso und schwarz.

Mesitas
Estructura de MDF, lacado mate en los colores talco, cera, cáñamo, caramelo, naranja, granate, verde prato, alga, espresso y negro.

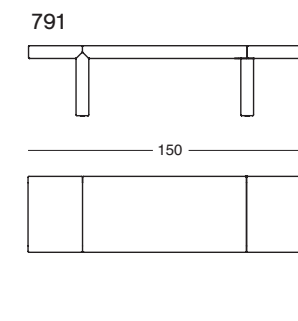
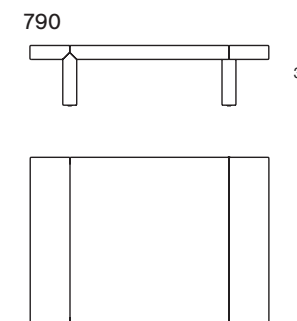

Dimensioni/Sizes/
Dimensions/
Abmessungen/
Medidas

790
84x120 cm
84x150 cm
120x120 cm

791
150x42 /H30 cm
150x42/H40 cm

Struttura/Frame/Structure/Gestell/Estructura





Design

Prospero Rasulo

2006

IN/OUT

Tavolino

Struttura in gres fine porcellanato antigelivo per esterni, con doppia smaltatura manuale a spessore controllato, cotto a 1250°C con un ciclo di lavorazione di 36 ore, colore blu-marrone.

Occasional table

Freeze resistant frame in fine porcelainized grès for outdoors use with thickness controlled two-layering applied by hand and baked at 1250°C with a 36-hour processing cycle, colour blue brown.

Petite table

Structure en grès fin émaillé résistante au gel pour externes, avec double émaillage manuel à épaisseur contrôlée, cuit à 1250°C en appliquant un cycle d'oeuvre de 36 heures, couleur bleu-brun.

Couchtisch

Gestell aus frostfestem und wetter-beständigem Feinsteinzeug, doppelte, dickenkontrollierte Handglasur, über 36 Stunden bei 1250 °C gebrannt, Farbe blau-braun.

Mesita

Estructura de gres fino porcelánico antihielo para uso exterior, con doble capa de esmalte a mano de espesor controlado, cocido a 1250°C con un ciclo de elaboración de 36 horas, color azul-marrón.

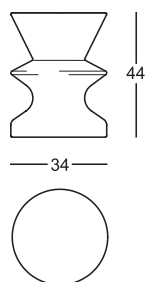

Design

Christian Woo

2025

Tavolini

Struttura in MDF impiallacciata in frassino laccato poro aperto colore talco, caramello, alga, amaranto e nero.

Small tables

MDF structure veneered with open-pore lacquered ash in talc, caramel, algae, amaranth and black.

Petites tables

Structure en MDF plaquée en frêne laqué pore ouvert dans les couleurs talc, caramel, algues, amarante et noir.

Beistelltische

Gestell aus MDF, offenporig lackierter Esche furniert in den Farben Talkum, Karamell, Algen, Amarantröt und schwarz.

Mesitas

Estructura en MDF chapada en fresno lacado a poro abierto en colores talco, caramelo, alga, granate y negro.

794

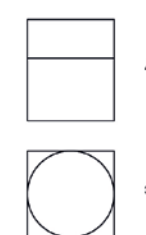

795

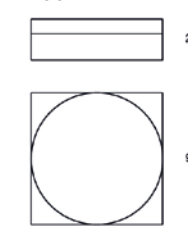

Struttura/Frame/Structure/Gestell/Estructura





Chairs

128–145

Sedie
Chaises
Stühle
Sillas



Design

Gae Aulenti

1964

IN/OUT

Sedia pieghevole

Struttura in acciaio inox. Snodi in lega di alluminio. Rivestimento sfilabile in Vip (per esterni), in Telastrong o in cuoio 95.

Folding chair

Stainless steel frame. Aluminum alloy joints. Removable cover in Vip (for outdoors), in Telastrong, or in cowhide 95.

Chaise pliante

Structure en acier inox. Articulations en alliage d'aluminium. Revêtement déhoussable en Vip (pour extérieurs), en Telastrong, ou en cuir sellier 95.

Klappsessel

Gestell aus Inox-Stahl. Gelenke aus Aluminiumlegierung. Abnehmbarer Bezug aus Vip (fürs Freie), aus Telastrong, oder aus Kernleder 95.

Silla plegable

Estructura de acero inox. Articulaciones de aleación de aluminio. Tapizado desenfundable de Vip (para exteriores), de Telastrong, o de cuero 95.

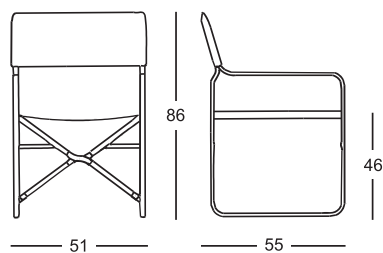

Design

Brogiato Traverso

2026

Sedia

Struttura in legno massello di frassino tinto rovere, tinto moka o laccato poro aperto nei colori amaranto e nero. Seduta e schienale in multistrato placcato frassino nei medesimi colori della struttura. Disponibile anche in versione con sedile imbottito in poliuretano espanso e rivestimento inamovibile in stoffa o in pelle.

Chair

Frame in solid oak - or mocha varnished ash, or open-pore lacquered in amaranth and black. Seat and backrest in ash-veneered plywood in the same colours as the frame. Also available with padded seat in polyurethane foam. Non-removable external cover in fabric or leather.

Chaise

Structure en frêne massif teinté rouvre ou moka, ou laqué à pores ouverts dans les couleurs rouge amarante et noir. Assise et dossier en contreplaqué plaqué frêne, dans les mêmes couleurs que le structure. Disponible également avec rembourrage de l'assise en mousse de polyuréthane. Revêtement extérieur inamovible en tissu ou en cuir.

Stuhl

Gestell aus massiver Esche, gebeizt in Eiche oder Mokka oder offenporig lackiert in den Farben Amarantröt und Schwarz. Sitzfläche und Rückenlehne aus Esche-furniertem Sperrholz in den gleichen Farben wie das Gestell. Auch erhältlich mit Sitzpolsterung aus Polyurethanschaum. Fester Außenbezug aus Stoff oder Leder

Silla

Estructura de fresno macizo teñido en roble o moka, o lacado a poro abierto en granate y negro. Asiento y respaldo de contrachapado chapado en fresno en los mismos colores que la estructura. Disponible también con asiento acolchado de espuma de poliuretano. Tapizado exterior fijo de tejido o piel.

2220

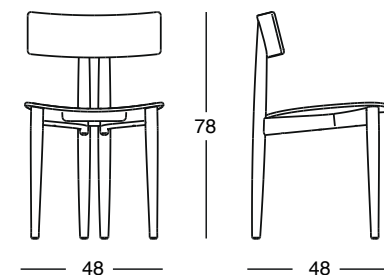

2220/R

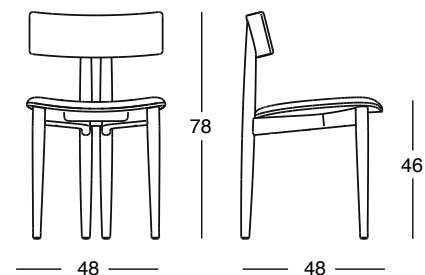

Struttura/Frame/Structure/Gestell/Estructura





Design

Vincent Van Duysen

2026

Sedia
Struttura in legno massello di frassino tinto rovere o tinto moka o laccato poro aperto nei colori amaranto e nero. Struttura seduta in fusione di alluminio con molleggio su nastri elastici, imbottitura seduta in poliuretano espanso con una percentuale di polioli

di origine biologica/fibra in PET con una percentuale di riciclato post-consumo. Disponibile anche con schienale in poliuretano rigido con imbottitura in poliuretano espanso. Rivestimento amovibile in stoffa o in pelle.

Chair
Frame in solid ash wood stained oak or stained mocha, or open-pore lacquered in amaranth and black. Seat frame in cast aluminum with elastic strip suspension; seat padding in polyurethane foam with a percentage of bio-based polyols/PET

fibre with a percentage of post-consumer recycled material. Also available with backrest in rigid polyurethane with polyurethane foam padding. Removable cover in fabric or leather.

Chaise
Structure en frêne massif teinté rovere ou moka, ou laqué à pores ouverts dans les couleurs rouge amarante et noir. Structure d'assise en fonte d'aluminium avec suspension sur sangles élastiques, rembourrage de l'assise en mousse de polyuréthane avec un

pourcentage de polyols d'origine biologique/fibres de PET avec un pourcentage de matériaux recyclés post-consommation. Disponible également avec dossier en polyuréthane rigide avec rembourrage en mousse de polyuréthane. Revêtement extérieur amovible en tissu ou en cuir.

Stuhl
Gestell aus massiver Esche, gebeizt in Eiche oder Mokka oder offenporig lackiert in den Farben Amarantrot und Schwarz. Sitzgestell aus Aluminiumguss mit Federung auf elastischen Gurten, Sitzpolsterung aus Polyurethanschäum mit

einem Anteil an Polyolen biologischen Ursprungs/PET-Fasern mit einem Anteil an Post-Consumer-Recyclingmaterial. Auch erhältlich mit Rückenlehne aus hartem Polyurethan mit Polsterung aus Polyurethanschäum. Abnehmbarer Außenbezug aus Stoff oder Leder.

Silla
Estructura de madera maciza de fresno teñida en roble o moka, o lacada con poro abierto en los colores granate y negro. Estructura del asiento de fundición de aluminio con suspensión sobre cintas elásticas; acolchado del asiento de espuma de poliuretano con

un porcentaje de polioles de origen biológico/fibra de PET con un porcentaje de material reciclado postconsumo. También disponible con respaldo de poliuretano rígido acolchado de espuma de poliuretano. Tapizado desenfundable en tejido o en piel.

2215

2215/R

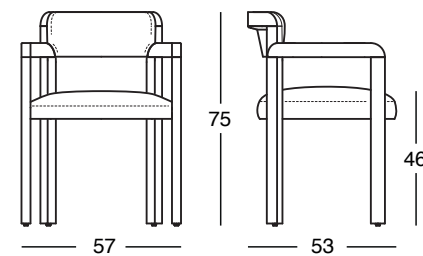
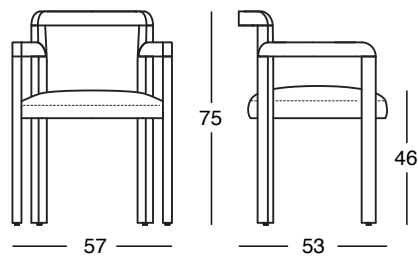

Struttura/Frame/Structure/Gestell/Estructura



Celestina ²²⁶⁰



Design

Marco Zanuso

1978

Sedia pieghevole
Struttura in acciaio verniciato, colore talco o nero. Sedile e schienale in nylon ricoperti in cuoio 95.

Folding chair
Frame in talc or black painted steel. Nylon seat and back covered in cowhide 95.

Chaise pliante
Structure en acier verni talc ou noir. Assise et dossier en nylon recouverts de cuir sellier 95.

Klappstuhl
Gestell aus Talkum oder schwarz lackiertem Stahl. Sitzfläche und Rückenlehne aus Nylon mit Kernleder 95 bezogen.

Silla plegable
Estructura de acero pintado en los colores: talco o negro. Asiento y respaldo de nylon tapizados de cuero 95.

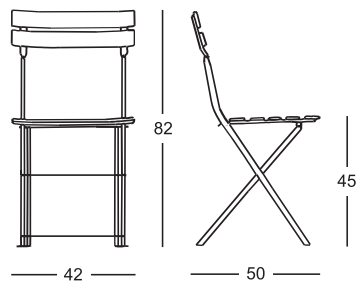

Struttura/Frame/Structure/ Gestell/ Estructura



Fenis CM ²⁰⁵¹



Design

Carlo Mollino

1959

Sedia
Struttura in legno massello di acero verniciato colore naturale o nero.

Chair
Frame in natural or black painted solid maple wood.

Chaise
Structure en érable massif verni couleur naturel ou noir.

Stuhl
Gestell aus massivem Ahornholz, naturfarben oder schwarz lackiert.

Silla
Estructura de madera de arce maciza con acabado en color natural o negro.

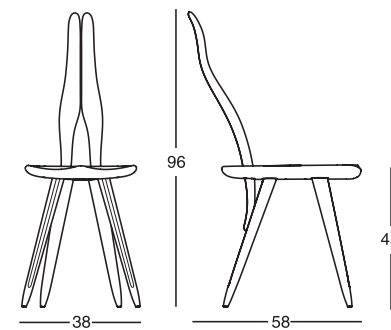

Struttura/Frame/Structure/ Gestell/Estructura





Design

Calvi Brambilla

2024

Poltroncina

Struttura in acciaio. Imbottitura struttura in poliuretano schiumato autoestinguente. Imbottitura cuscino di seduta realizzata con sfere di poliestere rigenerato e rigenerabile. Rivestimento amovibile in stoffa. La poltroncina è disponibile in versione fissa o in versione girevole.

Small armchair

Steel frame. Frame upholstered with self-extinguishing polyurethane foam. Seat cushion upholstered with regenerated and regenerable polyester balls. Removable fabric cover. The small armchair is available in a fixed or swivel version.

Petit fauteuil

Structure en acier. Rembourage de la structure en mousse de polyuréthane autoextinguible. Coussin assise en boules de polyester régénéré et régénérable. Revêtement amovible en tissu. Le petit fauteuil est disponible en version fixe ou pivotante.

Kleiner Sessel

Gestell aus Stahl. Selbstverlöschende Polyurethanschaum-Polsterung des Gestells. Sitz-Kissen aus regenerierten und regenerierbaren Polyesterkugeln. Abnehmbarer Bezug aus Stoff. Der kleine Sessel ist in einer festen oder drehbaren Version erhältlich.

Butaquita

Estructura de acero. Acolchado de la estructura de espuma de poliuretano autoextinguible. Cojín de asiento en bolas de poliéster regenerado y regenerable. Tapizado desenfundable en tejido. La butaquita está disponible en versión fija o giratoria

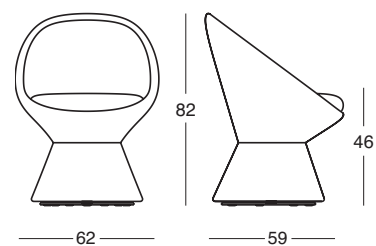

Design

Roberto Barbieri

2003

Sedia

Sedia con braccioli
Struttura in lega di alluminio. Sedile, schienale e braccioli imbottiti in poliuretano. Rivestimento sfilabile in stoffa o in pelle oppure non sfilabile in cuoio. A richiesta viene fornita una fodera coprisedia da calzare senza fissare: in tessuto 100% cotone, colore bianco, disponibile sia corta che ricopre sedile e schienale, sia lunga che ricopre anche le gambe.

Chair

Chair with armrests
Aluminium alloy frame. Seat, back and armrests upholstered in polyurethane. Removable cover in fabric or leather or non-removable in cowhide. Upon request one loose cover to be put on without fixing can be supplied: in 100% white cotton, available either short covering seat and backrest or long covering legs too.

Chaise

Chaise avec accoudoirs
Structure en alliage d'aluminium. Siège, dossier et accoudoirs rembourrés en polyuréthane. Revêtement déhoussable en tissu ou en cuir ou pas déhoussable en cuir sellier. Sur demande on peut fournir une housse à poser sans la fixer pour protéger les chaises : en tissu 100% coton, couleur blanche, dans les versions courte qui couvre assise et dossier ou longue qui couvre même les pieds.

Stuhl

Stuhl mit Armlehnen
Gestell aus Alu-Legierung. Sitz, Rückenlehne und Armlehnen Polyurethan-gepolstert. Abnehmbarer Bezug aus Stoff oder Leder oder aus nicht abnehmbarem Kernleder. Auf Nachfrage ist ein loser Bezug verfügbar, der auf dem Stuhl ohne befestigen anzuziehen ist: aus 100% weißer Baumwolle, in zwei Versionen lieferbar, kurz, der Sitz und Rücken überzieht, oder lang, der auch die Beine überzieht.

Silla

Silla con apoyabrazos
Estructura de aleación de aluminio. Asiento, respaldo y apoyabrazos acolchados en poliuretano. Tapizado desenfundable de tejido o de piel o no desenfundable de cuero. A pedido suministramos una funda de poner sobre la silla sin fijarla: de tejido 100% algodón, color blanco, disponible corta que cubre asiento y respaldo o larga que cubre también las patas.

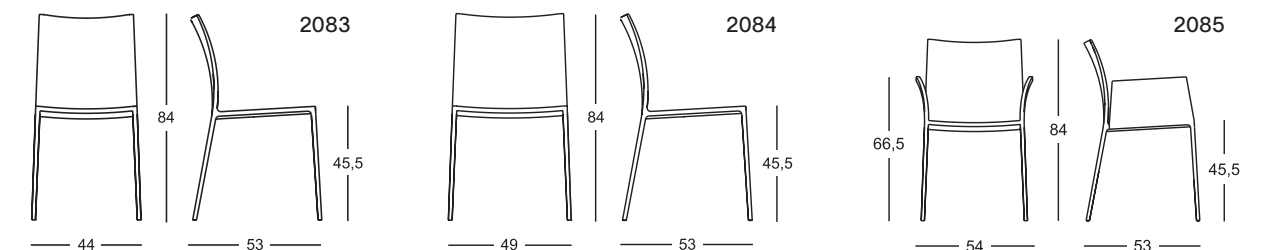



Design

Roberto Barbieri

2006

Sedia

Struttura in lega di alluminio. Sedile e schienale imbottiti in poliuretano. Rivestimento sfilabile in stoffa o in pelle oppure non sfilabile in cuoio. A richiesta viene fornita una fodera coprisedia da calzare senza fissare: in tessuto 100% cotone, colore bianco, disponibile sia corta che ricopre sedile e schienale, sia lunga che ricopre anche le gambe.

Chair

Aluminium alloy frame. Seat and back upholstered in polyurethane. Removable cover in fabric or leather or non-removable in cowhide. Upon request one loose cover to be put on without fixing can be supplied: in 100% white cotton, available either short covering seat and backrest or long covering legs too.

Chaise

Structure en alliage d'aluminium. Siège et dossier rembourrés en polyuréthane. Revêtement déhoussable en tissu ou en cuir ou pas déhoussable en cuir sellier. Sur demande on peut fournir une housse à poser sans la fixer pour protéger les chaises: en tissu 100% coton, couleur blanche, dans les versions courte qui couvre assise et dossier ou longue qui couvre même les pieds.

Stuhl

Gestell aus Aluminiumlegierung. Sitz und Rückenlehne Polyuethan-gepolstert. Abnehmbarer Bezug aus Stoff oder Leder oder aus nicht abnehmbarem Kernleder. Auf Nachfrage ist ein loser Bezug verfügbar, der auf dem Stuhl ohne befestigen anzuziehen ist: aus 100% weißer Baumwolle, in zwei Versionen lieferbar, kurz, der Sitz und Rücken überzieht, oder lang, der auch die Beine überzieht.

Silla

Estructura de aleación de aluminio. Asiento y respaldo acolchados en poliuretano. Tapizado desenfundable de tejido o de piel o no desenfundable de cuero. A pedido suministramos una funda de poner sobre la silla sin fijarla: de tejido 100% algodón, color blanco, disponible corta que cubre asiento y respaldo o larga que cubre también las patas.

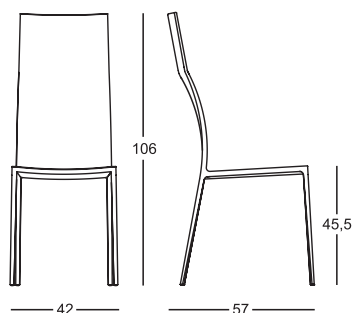

Design

Roberto Barbieri

1998-1999

Sedia

Sedia con braccioli
Struttura in lega di alluminio lucidato oppure verniciato, colore talco, grafite o nero. Sedile, schienale e braccioli imbottiti in poliuretano. Rivestimento sfilabile in stoffa o in pelle oppure non sfilabile in cuoio. A richiesta viene fornita una fodera coprisedia da calzare senza fissare: in tessuto 100% cotone, colore bianco, disponibile sia corta che ricopre sedile e schienale, sia lunga che ricopre anche le gambe.

Chair

Chair with armrests
Aluminum alloy frame, polished or painted talc, graphite or black. Seat, back and armrests upholstered in polyurethane. Removable cover in fabric or leather or non-removable in cowhide. Upon request one loose cover to be put on without fixing can be supplied: in 100% white cotton, available either short covering seat and backrest or long covering legs too.

Chaise

Chaise avec accoudoirs
Structure en alliage d'aluminium poli ou verni couleur talc, graphite ou noir. Siège, dossier et accoudoirs rembourrés en polyuréthane. Revêtement déhoussable en tissu ou en cuir ou pas déhoussable en cuir sellier. Sur demande on peut fournir une housse à poser sans la fixer pour protéger les chaises: en tissu 100% coton, couleur blanche, dans les versions courte qui couvre assise et dossier ou longue qui couvre même les pieds.

Stuhl

Stuhl mit Armlehnen
Gestell aus polierter Aluminiumlegierung oder Talkum, Graphit oder schwarz lackiert. Sitz, Rückenlehne und Armlehnen Polyuethan-gepolstert. Abnehmbarer Bezug aus Stoff oder Leder oder aus nicht abnehmbarem Kernleder. Auf Nachfrage ist ein loser Bezug verfügbar, der auf dem Stuhl ohne befestigen anzuziehen ist: aus 100% weißer Baumwolle, in zwei Versionen lieferbar, kurz, der Sitz und Rücken überzieht, oder lang, der auch die Beine überzieht.

Silla

Silla con apoyabrazos
Estructura de aleación de aluminio pulido o barnizado color talco, grafito o negro. Asiento, respaldo y apoyabrazos acolchados en poliuretano. Tapizado desenfundable de tejido o de piel o no desenfundable de cuero. A pedido suministramos una funda de poner sobre la silla sin fijarla: de tejido 100% algodón, color blanco, disponible corta que cubre asiento y respaldo o larga que cubre también las patas.

2086

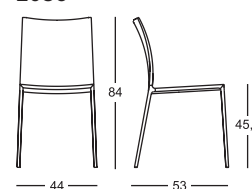

2087

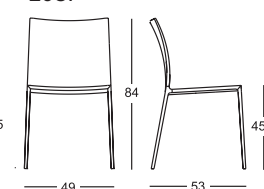

2088

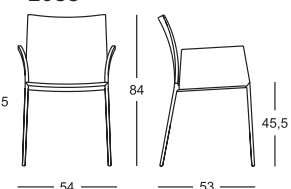

Struttura/Frame/Structure/ Gestell/Estructura



Lialta 2082



Design

Roberto Barbieri

2006

Sedia

Struttura in lega di alluminio lucidato oppure verniciato colore talco, grafite o nero. Sedile e schienale imbottiti in poliuretano. Rivestimento sfilabile in stoffa o in pelle oppure non sfilabile in cuoio. A richiesta viene fornita una fodera coprisedia da calzare senza fissare: in tessuto 100% cotone, colore bianco, disponibile sia corta che ricopre sedile e schienale, sia lunga che ricopre anche le gambe.

Chair

Aluminum alloy frame, polished or painted talc, graphite or black. Seat and back upholstered in polyurethane. Removable cover in fabric or leather or non-removable in cowhide. Upon request one loose cover to be put on without fixing can be supplied: in 100% white cotton, available either short covering seat and backrest or long covering legs too.

Chaise

Structure en alliage d'aluminium poli ou verni couleur talc, graphite ou noir. Siège et dossier rembourrés en polyuréthane. Revêtement déhoussable en tissu ou en cuir ou pas déhoussable en cuir sellier. Sur demande on peut fournir une housse à poser sans la fixer pour protéger les chaises: en tissu 100% coton, couleur blanche, dans les versions courte qui couvre assise et dossier ou longue qui couvre même les pieds.

Stuhl

Gestell aus polierter Aluminiumlegierung oder Talkum, Graphit oder schwarz lackiert. Sitz und Rückenlehne Polyurethan-gepolstert. Abnehmbarer Bezug aus Stoff oder Leder oder aus nicht abnehmbarem Kernleder. Auf Nachfrage ist ein loser Bezug verfügbar, der auf dem Stuhl ohne befestigen anzuziehen ist: aus 100% weißer Baumwolle, in zwei Versionen lieferbar, kurz, der Sitz und Rücken überzieht, oder lang, der auch die Beine überzieht.

Silla

Estructura de aleación de aluminio pulido o barnizado color talco, grafito o negro. Asiento y respaldo acolchados en poliuretano. Tapizado desenfundable de tejido o de piel o no desenfundable de cuero. A pedido suministramos una funda de poner sobre la silla sin fijarla: de tejido 100% algodón, color blanco, disponible corta que cubre asiento y respaldo o larga que cubre también las patas.

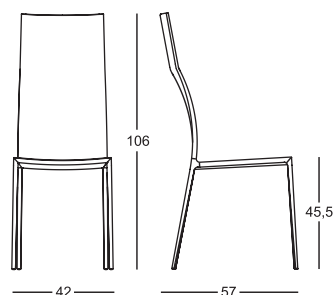

Struttura/Frame/Structure/ Gestell/Estructura



Lio/Leo 2291/2292



Design

Roberto Barbieri

2005

Sgabelli

Struttura in lega di alluminio (2292) oppure in lega di alluminio lucidato o verniciato colore talco, grafite o nero (2291). Sedile e schienale imbottiti in poliuretano. Rivestimento sfilabile in stoffa o in pelle oppure non sfilabile in cuoio. Poggiatesta in acciaio inox satinato. A richiesta viene fornita una fodera copri sgabello, in tessuto 100% cotone, colore bianco, da calzare senza fissare, che ricopre sedile e schienale.

Stools

Frame in aluminum alloy (2292) or in polished aluminum alloy, or painted talc, graphite or black (2291). Seat and back with polyurethane upholstery. Removable cover in fabric or leather or non-removable in cowhide. Footrest in satin-finished stainless steel. Upon request a 100% white cotton loose stool cover to be put on without fixing, covering seat and backrest, can be supplied.

Tabourets

Structure en alliage d'aluminium (2292) ou en alliage d'aluminium poli, ou verni couleur talc, graphite ou noir (2291). Assise et dossier rembourrés en polyuréthane. Revêtement déhoussable en tissu ou en cuir ou pas déhoussable en cuir sellier. Appuie-pieds en acier inox satiné. Sur demande on va fournir une housse qui protège le tabouret en tissu 100% coton, couleur blanche, de poser sans la fixer, qui couvre assise et dossier.

Hocker

Gestell aus Aluminiumlegierung (2292) oder aus polierter Aluminiumlegierung, oder Talkum, Graphit oder schwarz lackiert (2291). Sitz und Rückenlehne mit Polsterung aus Polyurethan. Abnehmbarer Außenbezug aus Stoff oder Leder oder aus nicht abnehmbarem Kernleder. Fußstütze aus satiniertem Edelstahl. Auf Nachfrage ist ein loser Bezug aus 100% weißer Baumwolle lieferbar, der auf dem Hocker ohne befestigen anzuziehen ist und Sitz und Rücken überzieht.

Taburetes

Estructura de aleación de aluminio (2292) o de aleación de aluminio pulido o barnizado color talco, grafito o negro (2291). Asiento y respaldo acolchados de poliuretano. Tapizado desenfundable de tejido o de piel o no desenfundable de cuero. Reposapiés de acero inoxidable satinado. A pedido suministramos una funda que protege el taburete de tejido 100% algodón, color blanco, de poner sobre el taburete sin fijarla, que cubre asiento y respaldo.

2291/A h 76 cm / 2291/B h 66 cm

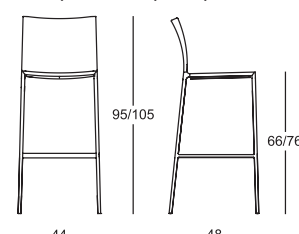

2292/A h 76 cm / 2292/B h 66 cm

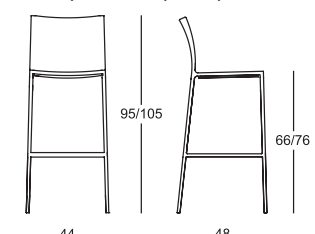

Struttura/Frame/Structure/ Gestell/Estructura (mod. 2291)



Nellee 2263



Design

Calvi Brambilla

2025

Sedia
Struttura in acciaio.
Imbottitura in poliuretano
schiumato autoestinguente
con una percentuale
di polioli di origine biologica.
Rivestimento amovibile
in stoffa o in pelle.

Chair
Steel frame. Upholstery
in self-extinguishing
polyurethane foam with
a percentage of bio-based
polyols. Removable cover
in fabric or leather.

Chaise
Structure en acier.
Rembourrage en mousse
de polyuréthane
auto-extinguible avec
un pourcentage de polyols
d'origine biologique.
Revêtement amovible
en tissu ou en cuir.

Stuhl
Gestell aus Stahl. Polsterung
aus selbstverlöschendem
Polyurethanschaum mit
einem Anteil an Polyolen
biologischen Ursprungs.
Abnehmbarer Bezug aus
Stoff oder Leder.

Silla
Estructura en acero.
Acolchado en espuma
de poliuretano autoextinguible
con un porcentaje de
polioles de origen biológico.
Tapizado desenfundable
en tejido o in piel.

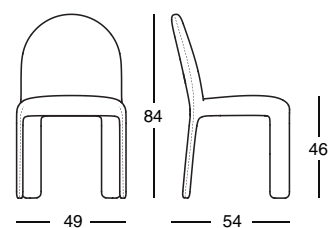

Nena 2262



Design

Lanzavecchia+Wai

2020

Poltroncina
Struttura in acciaio
verniciato colore arancione,
amaranto, espresso, grafite
o nero. Imbottitura sedile
e schienale in poliuretano.
Rivestimento sfilabile in
stoffa o in pelle.

Armchair
Steel frame varnished
orange, amaranth, espresso,
graphite or black. Seat and
backrest upholstered with
polyurethane. Removable
fabric or leather cover.

Petit fauteuil
Structure en acier verni
orange, rouge amarante,
espresso, graphite ou noir.
Assise et dossier rembourrés
en polyuréthane. Revêtement
déhoussable en tissu ou en
cuir.

Sessel
Gestell aus orange,
amarantrot, espresso, graphit
oder schwarz lackiertem
Stahl. Sitz- und Rückenlehne
Polsterung mit Polyurethan
gepolstert. Abnehmbarer
Bezug aus Stoff oder Leder.

Butaquita
Estructura de acero pintado
en los colores naranja,
granate, espresso, grafito
o negro. Acolchado del
asiento y del respaldo
en poliuretano. Tapizado
desenfundable de tejido
o piel.

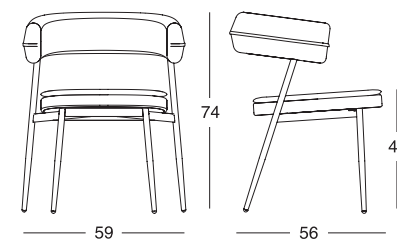

Struttura/Frame/Structure/ Gestell/Estructura



Nena Stool ²²⁹³



Design

Lanzavecchia+Wai

2022

Sgabello

Struttura in acciaio verniciato colore arancione, amaranto, espresso, grafite o nero. Imbottitura sedile e schienale in poliuretano. Rivestimento sfilabile in stoffa o in pelle. Poggiapiedi ricoperto in acciaio inox satinato.

Stool

Steel frame varnished orange, amaranth, espresso, graphite or black. Seat and backrest upholstered with polyurethane. Removable fabric or leather cover. Footrest covered with satin-finished stainless steel.

Tabouret

Structure en acier verni orange, rouge amarante, espresso, graphite ou noir. Assise et dossier rembourrés en polyuréthane. Revêtement déhoussable en tissu ou en cuir. Appuie-pieds recouvert en acier inox satiné.

Hocker

Gestell aus orange, amaranthrot, espresso, graphit oder schwarz lackiertem Stahl. Sitz- und Rückenlehne Polsterung mit Polyurethan gepolstert. Abnehmbarer Bezug aus Stoff oder Leder. Fußstütze bezogen mit satiniertem Inox-Stahl.

Taburete

Estructura de acero pintado en los colores naranja, granate, espresso, grafito o negro. Acolchado del asiento y del respaldo en poliuretano. Tapizado desenfundable de tejido o piel. Reposapiés recubierto de acero inoxidable satinado.

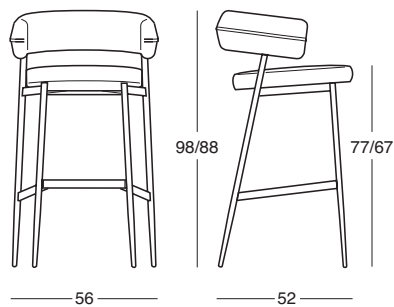

Struttura/Frame/Structure/ Gestell/Estructura





Design

Roberto Barbieri

2007

Sedia impilabile

Struttura in lega di alluminio lucidato oppure verniciato colore talco, grafite o nero. Sedile e schienale imbottiti in poliuretano. Rivestimento sfilabile in stoffa o in pelle oppure non sfilabile in cuoio. A richiesta viene fornita una fodera coprisedia da calzare senza fissare: in tessuto 100% cotone, colore bianco, disponibile sia corta che ricopre sedile e schienale, sia lunga che ricopre anche le gambe. A richiesta è disponibile un carrello per il trasporto delle sedie impilate (massimo 15 sedie).

Stackable chair

Aluminum alloy frame, polished or painted talc, graphite or black. Seat and back upholstered in polyurethane. Removable cover in fabric or leather or non-removable in cowhide. Upon request one loose cover to be put on without fixing can be supplied: in 100% white cotton, available either short covering seat and backrest or long covering legs too. Upon request a trolley for carrying the stacked chairs (max 15 chairs) is available.

Chaise superposable

Structure en alliage d'aluminium poli ou verni, couleur talc, graphite ou noir. Siège et dossier rembourrés en polyuréthane. Revêtement déhoussable en tissu ou en cuir ou pas déhoussable en cuir sellier. Sur demande on peut fournir une housse à poser sans la fixer pour protéger les chaises: en tissu 100% coton, couleur blanche, dans les versions courte qui couvre assise et dossier ou longue qui couvre même les pieds. Sur demande est disponible aussi un chariot pour déplacer les chaises superposées (maximum 15 chaises).

Stapelbarer Stuhl

Gestell aus polierter Aluminiumlegierung oder Talkum, Graphit oder schwarz lackiert. Sitz und Rückenlehne Polyurethan-gepolstert. Abnehmbarer Bezug aus Stoff oder Leder oder aus nicht abnehmbarem Kernleder. Auf Nachfrage ist ein loser Bezug verfügbar, der auf dem Stuhl ohne befestigen anzuziehen ist: aus 100% weißer Baumwolle, in zwei Versionen lieferbar, kurz, der Sitz und Rücken überzieht, oder lang, der auch die Beine überzieht. Auf Nachfrage ist ein Wagen zum Transport der gestapelten Stühle (max 15 Stühle) lieferbar.

Silla apilable

Estructura de aleación de aluminio pulido o pintado de color talco, grafito o negro. Asiento y respaldo acolchados en poliuretano. Tapizado desenfundable de tejido o de piel o no desenfundable de cuero. A pedido suministramos una funda de poner sobre la silla sin fijarla: de tejido 100% algodón, color blanco, disponible corta que cubre asiento y respaldo o larga que cubre también las patas. A pedido suministramos un carro para transportar las sillas apiladas (máximo 15 sillas).

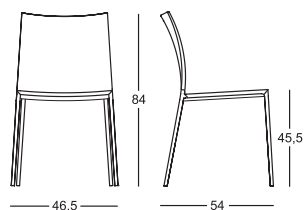

Struttura/Frame/Structure/ Gestell/Estructura



Design

Enzo Mari

1985

Sedia

Struttura in lega di alluminio lucidato o verniciato nero. Sedile e schienale in polipropilene ricoperto in cuoio 95 nei colori della cartella.

Chair

Polished or black painted aluminum alloy frame. Seat and back in polypropylene covered in cowhide 95 in the colours indicated on our colour card.

Chaise

Structure en alliage d'aluminium poli ou verni noir. Assise et dossier en polypropylène recouverts en cuir sellier 95 dans les couleurs de la fiche.

Stuhl

Gestell aus polierter oder schwarz lackierter Aluminiumlegierung. Sitzfläche und Rückenlehne aus Polypropylen mit Kernleder 95 bezogen in den Farben der Musterkarte.

Silla

Estructura de aleación de aluminio pulido o pintado negro. Asiento y respaldo de polipropileno tapizado con cuero 95 en los colores del muestrario.

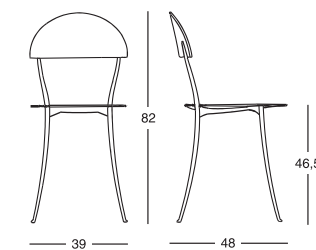

Struttura/Frame/Structure/ Gestell/Estructura





Tables, Console Tables, Desks

Tavoli, Consolle,
Scrivanie
Tables, Consoles,
Tables Bureau
Tische,
Wandtische,
Schreibtische
Mesas, Consolas,
Mesas Escritorios

148–181



Design

Zaven

2023

Tavolo

Basi in poliuretano rigido laccate opache o lucide colore talco, canapa, caramello, alga, amaranto, espresso e nero, in abbinamento a piani in MDF nei medesimi colori laccati opachi talco, canapa, caramello, alga, amaranto, espresso e nero.

Table

Hard polyurethane bases matt or glossy lacquered in the shades talc, hemp, caramel, algae, amaranth, espresso and black, in combination with MDF tops in the same matt lacquered colours talc, hemp, caramel, algae, amaranth, espresso and black.

Table

Bases en polyuréthane rigide laqué mat ou brillant dans les couleurs talc, chanvre, caramel, algues, rouge amarante, espresso et noir, en combinaison avec des plateaux en MDF dans les mêmes couleurs laquées mat talc, chanvre, caramel, algues, rouge amarante, espresso et noir.

Tisch

Untergestelle aus hartem Polyurethan, matt oder glänzend lackiert in den Farben Talkum, Hanf, Karamell, Algen, Amaranrot, Espresso und schwarz, in Kombination mit MDF-Platten in den gleichen matt lackierten Farben Talkum, Hanf, Karamell, Algen, Amaranrot, Espresso und schwarz.

Mesa

Bases de poliuretano rígido lacado mate o brillante en colores talco, cañamo, caramelo, alga, granate, espresso y negro, en combinación con sobres de MDF en los mismos colores lacado mate talco, cañamo, caramelo, alga, granate, espresso y negro.

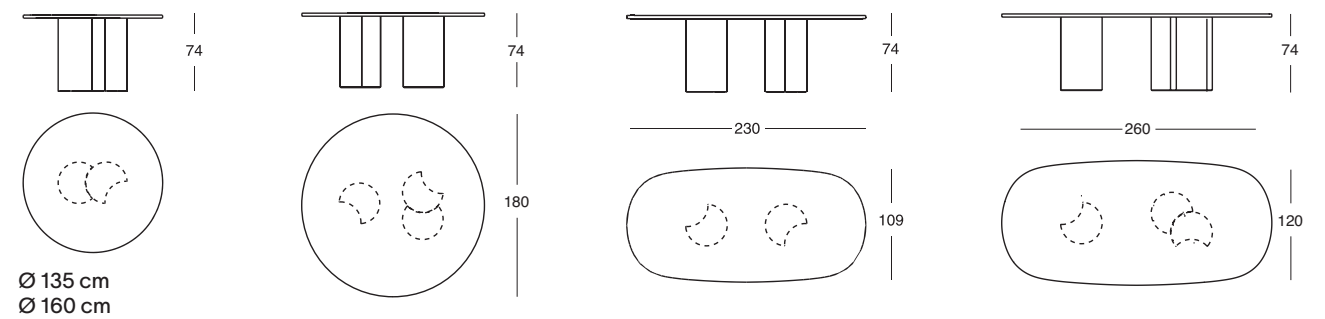

Struttura/Frame/Structure/Gestell/Estructura





Design

Zaven

2023

Tavolo

Basi in poliuretano rigido laccate opache o lucide colore talco, canapa, caramello, alga, amaranto, espresso e nero, in abbinamento a piani in MDF nei medesimi colori laccati opachi talco, canapa, caramello, alga, amaranto, espresso e nero con inserimento di piano in cristallo extra light, spessore 8 mm, temperato, retro verniciato nello stesso colore.

Table

Hard polyurethane bases matt or glossy lacquered in the shades talc, hemp, caramel, algae, amaranth, espresso and black, in combination with MDF tops in the same matt lacquered colours talc, hemp, caramel, algae, amaranth, espresso and black with inclusion of extra light glass top, 8 mm thick, tempered, back painted in the same colour.

Table

Bases en polyuréthane rigide laqué mat ou brillant dans les couleurs talc, chanvre, caramel, algues, rouge amarante, espresso et noir, en combinaison avec des plateaux en MDF dans les mêmes couleurs laquées mat talc, chanvre, caramel, algues, rouge amarante, espresso et noir avec insertion d'un plateau en cristal extra clair, épaisseur 8 mm, trempé, dos verni dans la même couleur.

Tisch

Untergestelle aus hartem Polyurethan, matt oder glänzend lackiert in den Farben Talkum, Hanf, Karamell, Algen, Amarantröt, Espresso und schwarz, in Kombination mit MDF-Platten in den gleichen matt lackierten Farben Talkum, Hanf, Karamell, Algen, Amarantröt, Espresso und schwarz mit dem Einsatz einer extra leichten, Stärke 8 mm, gehärteten Glasplatte, die in der gleichen Farbe nach hinten lackiert ist.

Mesa

Bases de poliuretano rígido lacado mate o brillante en colores talco, cañamo, caramelo, alga, granate, espresso y negro, en combinación con sobres de MDF en los mismos colores lacado mate talco, cañamo, caramelo, alga, granate, espresso y negro con la inserción de un sobre de cristal templado extra claro, de 8 mm de espesor, en la parte trasera lacado en el mismo color.

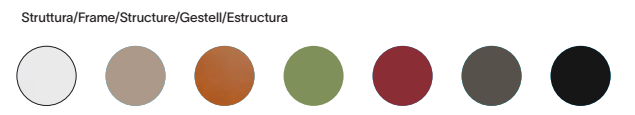
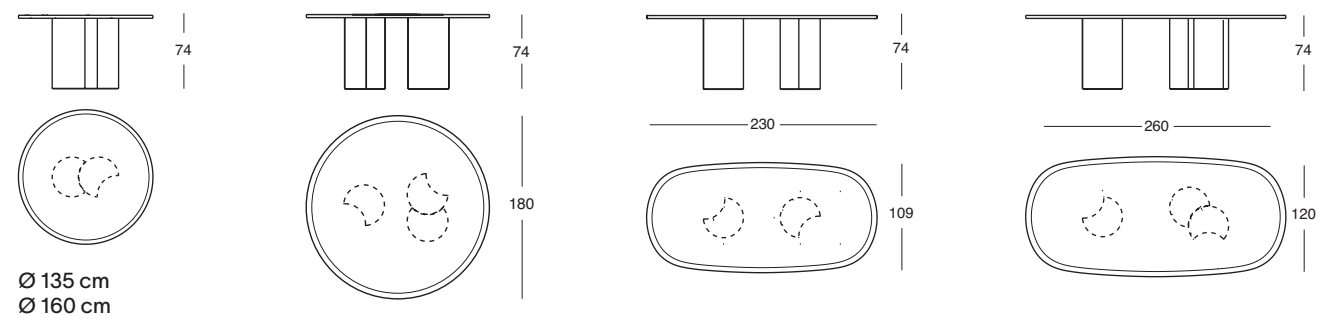

Lazy Susan ²³²⁷



Piatto da tavola girevole
Base girevole su sfere metalliche. Piano in MDF laccato opaco colore talco, canapa, caramello, alga, amaranto, espresso o nero.

Revolving table plate
Swivel base on metal spheres. Matt lacquered MDF top in talc, hemp, caramel, algae, amaranth, espresso or black.

Plateau de table rotatif
Base pivotante sur sphères en métal. Plateau en MDF laqué mat en talc, chanvre, caramel, algue, rouge amarante, espresso ou noir.

Drehbare Tischplatte
Drehbarer Fuß auf Metallkugeln. Matt lackierte MDF-Platte in Talkum, Hanf, Karamell, Algen, Amaranthrot, Espresso oder schwarz.

Plato de mesa giratoria
Base giratoria sobre esferas metálicas. Tablero de MDF lacado mate en talco, cáñamo, caramelo, alga, granate, espresso o negro.

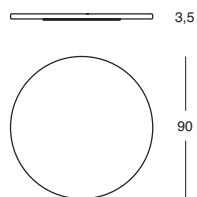

Struttura/Frame/Structure/Gestell/Estructura



Calamo ²⁷³⁰



Design

Gabriele Rosa

2013

Scrittoio
Struttura e piano in acciaio verniciato colore talco, grafite o nero. Piano e vano portaoggetti in cuoio pigmentato 90. Il vano è accessibile mediante apertura a ribalta.

Desk
Varnished steel frame and top in talc, graphite or black. Top and storage space in cowhide pigmentato 90. The storage space is accessed by a drop-leaf opening.

Table bureau
Structure et plateau en acier verni couleur talc, graphite ou noire. Plateau et élément porte-objets en cuir sellier pigmentato 90. L'élément est accessible par une ouverture basculante.

Schreibtisch
Gestell und Platte aus Talkum-graphitfarben oder schwarz lackiertem Stahl. Platte und Ablagefach aus Kernleder pigmentato 90. Das Ablagefach ist mit Kippöffnung versehen.

Escritorio
Estructura y sobre de acero barnizado color talco, grafito o negro. Sobre y compartimento portaobjetos de cuero pigmentato 90. Se puede acceder al compartimento mediante apertura abatible.

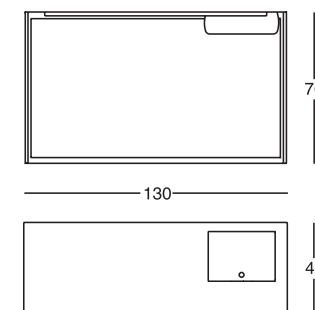

Struttura/Frame/Structure/Gestell/Estructura





Design

Vincent Van Duysen

2026

Tavolo

Anima strutturale in acciaio verniciata colore nero. Struttura in legno massello di frassino tinto rovere o tinto moka o laccato poro aperto nei colori amaranto e nero. Piani in cristallo spessore 8 mm temperato, retro verniciato nei colori amaranto in abbinamento alla struttura laccata amaranto, espresso in abbinamento alla struttura tinto rovere e tinto moka, nero in abbinamento alla struttura laccata nera, oppure piano in cuoio

colore tabacco 0813 in abbinamento alla struttura tinto rovere, piano in cuoio colore testa di moro 0806 in abbinamento alla struttura tinto rovere, piano in cuoio colore fango 0841 in abbinamento alla struttura tinto rovere, piano in cuoio colore nero 0801 in abbinamento alla struttura laccata nera, piano in cuoio colore grigio antracite 0807 in abbinamento alla struttura tinto moka, oppure piani in MDF impiallacciato in frassino nei medesimi colori della struttura.

Table

Black painted structural steel frame. Frame in solid oak - or mocha varnished ash, or open-pore lacquered in amaranth and black. Tops in 8 mm thick tempered plate glass, back painted in amaranth to match the amaranth lacquered frame, espresso to match the oak-varnished and mocha-varnished frames, black to match the black lacquered frame, or tops in tobacco 0813 cowhide to match the oak-varnished frame, in dark brown 0806

cowhide to match the oak-varnished frame, in mud 0841 cowhide to match the oak-varnished frame, in black 0801 cowhide matching the black lacquered frame, in anthracite grey 0807 cowhide matching the mocha-varnished frame, or tops in ash-veneered MDF in the same colours as the frame.

Table

Structure en acier peint en noir. Structure en frêne massif teinté rouvre ou moka, ou laqué à pores ouverts dans les couleurs rouge amarante et noir. Plateaux en verre trempé de 8 mm d'épaisseur, dos laqué en couleur rouge amarante en combinaison avec la structure laquée amarante, espresso en combinaison avec la structure teintée rouvre et teintée noire, ou plateau en cuir

sellier couleur tabac 0813 en combinaison avec la structure teintée rouvre, plateau en cuir sellier couleur marron foncé 0806 en combinaison avec la structure teintée rouvre, plateau en cuir sellier couleur boue 0841 en combinaison avec la structure laquée noire, plateau en cuir sellier gris anthracite 0807 en combinaison avec la structure teinté moka, ou plateaux en MDF plaqué frêne dans les mêmes couleurs que la structure.

Tisch

Tragendes Gestell aus schwarz lackiertem Stahl. Gestell aus massiver Esche, gebeizt in Eiche oder Mokka oder offenporig lackiert in den Farben Amarantröt und Schwarz. Tischplatten aus 8 mm starkem, gehärtetem Glas, Rückseite lackiert in den Farben Amarantröt passend zum amarantrötlackierten Gestell, Espresso passend zum Eiche- oder Mokka gebeizten Gestell, Schwarz passend zum schwarzlackierten Gestell, oder Kernlederplatte in der Farbe Tabak 0813 passend zum Eiche-gebeizten

Gestell, Kernlederplatte in der Farbe Dunkelbraun 0806 passend zum Eiche-gebeizten Gestell, Kernlederplatte in der Farbe Schlamm 0841 passend zum Eiche-gebeizten Gestell, Kernlederplatte in Schwarz 0801 passend zum schwarzlackierten Gestell, Kernlederplatte in Anthrazitgrau 0807 passend zum mokkafarbenen Gestell, oder MDF-Platten mit Eschenfurnier in den gleichen Farben wie das Gestell.

Mesa

Estructura de acero pintada en negro. Estructura de fresno macizo teñido en roble o moka, o lacado a poro abierto en granate y negro. Sobres de cristal templado de 8 mm de espesor, con parte trasera pintada en color granate combinada con la estructura lacada en granate, en color espresso combinada con la estructura teñida en roble y moka, en negro combinada con la estructura lacada en negro, o sobre de cuero color tabaco 0813 combinado con la estructura teñida en roble, sobre de cuero color marrón oscuro

0806 combinado con la estructura teñida de roble, sobre de cuero color barro 0841 combinado con la estructura teñida de roble, sobre de cuero color negro 0801 combinado con la estructura lacada en negro, sobre de cuero color gris antracita 0807 combinado con la estructura teñida en moka, o sobres de MDF chapado en fresno en los mismos colores de la estructura.



180x100cm
200x100cm
240x100cm
150x150cm



Cavour CM 2690

* Vedi nota a fine catalogo
 * See note at the end of the catalogue
 * Voir la note en fin de catalogue
 * Siehe Hinweis am Ende des Katalogs
 * Ver nota al final del catálogo



Design

Carlo Mollino

1949

Tavolo scrivania

Gambe in legno massello di rovere naturale o tinto nero, oppure in legno massello di noce Canaletto; verniciatura con finitura a cera. Cassettiera e piano estraibile impiallacciati in rovere naturale o tinto nero, oppure in noce Canaletto, verniciatura con finitura a cera, entrambi rivestiti con cristallo temperato, extra-chiaro, retro-verniciato nero. Piano in cristallo trasparente o extra-chiaro, oppure cristallo fumé grigio, in

abbinamento alla struttura in rovere tinto nero. A richiesta è disponibile un Executive kit che prevede il rivestimento in cuoio nero del fondo del piano estraibile e del primo cassetto della cassettiera, un sottomano in cuoio nero e un portapenne in legno massello realizzato nelle medesime finiture della scrivania.

Writing desk

Pieds en rouvre naturel or black varnished oak, or in solid Canaletto walnut; wax-finished varnish. Extractable open tray and drawer element veneered in natural or black varnished oak, or in Canaletto walnut, wax-finished varnish, both covered with extra-clear tempered plate glass, back-painted in black. Clear or extra clear plate glass top, or smoky grey plate glass top, matching the black oak frame. Upon request an

Executive kit is available, including the bottom of the extractable open tray and the first drawer covered with black cowhide, one desk pad in black cowhide and one penholder in solid wood, made in the same finishes as the writing desk.

Table bureau

Pieds en rouvre naturel massif ou teinté noir ou en noyer Canaletto massif; verni finition cirée. Bloque tiroirs et plateau coulissant plaqués en rouvre naturel ou teinté noir, ou en noyer Canaletto, verni finition cirée, les deux recouverts en verre trempée, extra clair, dos-verni noir. Plateau en verre extra clair ou transparent, ou en verre gris fumé, en combinaison avec la structure en rouvre teinté noir. Sur demande il est disponible un Executive

kit pour recouvrir en cuir sellier noir le fond du plateau coulissant et du premier tiroir du caisson, un sous-main en cuir sellier noir et pot à crayons en bois massif réalisé dans les mêmes finitions du bureau.

Schreibtisch

Beine aus massiver naturfarbener oder schwarz gebeizter Eiche, oder aus massivem Nussbaum Canaletto; Lackierung mit Wachs-Endbehandlung. Ausziehbares offenes Tablett und Schublade furniert mit naturfarbener oder schwarz gebeizter Eiche, oder mit Nussbaum Canaletto; Lackierung mit Wachs-Endbehandlung. Beide sind bezogen mit extra-klaarem gehärtetem und nach hinten schwarz lackiertem Kristallglas.

Tischplatte aus transparentem oder extra-klaarem Kristallglas, oder aus grau rauchfarbenem Kristallglas, passend zum Gestell aus schwarz gebeizter Eiche. Auf Nachfrage ist ein Executive Kit verfügbar, das den Bodenbezug des ausziehbaren offenen Tablettes und der ersten Schubladen aus schwarzem Kernleder, sowie eine Schreibunterlage aus schwarzem Kernleder, und einen Holzstifthalter in den gleichen Ausführungen des Schreibtisches enthält.

Mesa escritorio

Patatas de madera maciza de roble natural o teñido negro o de nogal Canaletto macizo; pintura con acabado de cera. Cajonera y top extraíble contrachapados de roble natural o teñido negro, o de nogal Canaletto, pintura con acabado de cera, ambos tapizados de cristal templado extra claro, parte trasera pintada negra. Superficie de cristal transparente o extra claro, o de cristal gris humo, combinado con la estructura de roble teñido negro. Sobre

pedido es disponible un Executive kit para tapizar de cuero negro el fondo del top extraíble y del primero cajón de la cajonera, un despad de cuero negro y un portalápiz de madera maciza realizado en los mismos acabados del escritorio.

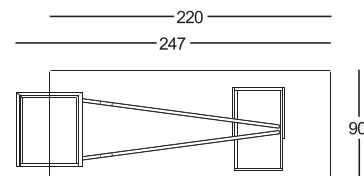
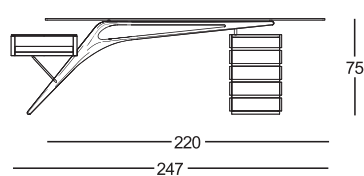

Struttura/Frame/Structure/Gestell/Estructura

Rovere naturale/
Natural oakwood/
Rouvre naturel/
Naturfarbene
Eiche/Roble
natural



Rovere tinto nero/
Black varnished
oak/Rouvre teinté
noir/Schwarz-
gebeizte Eiche/
Roble teñido negro



Noce Canaletto/
Canaletto walnut/
Noyer Canaletto/
Nussbaum
Canaletto/Nogal
Canaletto



Executive Kit

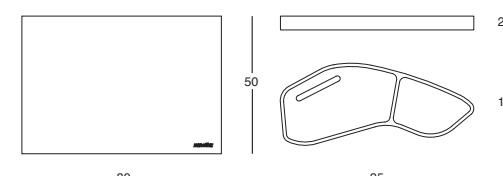

Piano/Top/Plateau/Platte/Sobre

Cristallo
trasparente/
Transparent
plate glass/Verre
transparent/
Transparentes
Kristallglas/Cristal
transparente



Cristallo extra-
chiaro/Extra-clear
plate glass/Verre
extra-clair/Extra-
klares Kristallglas/
Cristal extra-claro



Cristallo fumé
grigio/Smoky
grey plate glass/
Verre gris fumé/
Rauchfarbenes
Kristallglas/Cristal
gris humo



Comacina ²⁷²⁵



Design

Piero Bottoni

1930

Scrivania

Struttura in tubo di acciaio inox. Piano e cassetteria verniciati gofrati antigraffio nei colori talco o nero. Il piano può essere con inserto in cuoio pigmentato.

Writing desk

Stainless steel tubular frame. Top and drawer unit finished with scratch resistant embossing in the colours talc or black. The top can be with cowhide pigmentato insert.

Table bureau

Structure en tube d'acier inox. Plateau et caisson vernis anti-rayures dans les couleurs talc ou noire. Le plateau peut être avec finition en cuir sellier pigmentato.

Schreibtisch

Gestell aus Inox-Stahl-Rohr. Platte und Schubladen mit kratzfester Lackierung in den Farben Talkum oder schwarz. Die Platte ist auch mit eingelegtem Kernleder pigmentato.

Mesa escritorio

Estructura en tubo de acero inox. Sobre y cajonera lacados con relieve antirasguño en los colores talco o negro. El sobre puede ser también con inserción de cuero pigmentato.

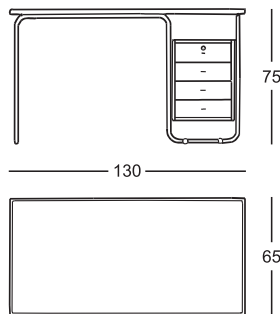

Struttura/Frame/Structure/Gestell/Estructura



Fenice ²⁵⁷⁴



Design

Piero Bottoni

1936

Tavolo

Esemplare numerato. Struttura in Polimex®, rivestita in cemento con finitura acrilica e trattamento di protezione nano tecnologico antimacchia a base di biossido di titanio, colore grigio.

Table

Numbered piece. Frame in Polimex®, covered with acryl finish cement with protective titanium dioxide nanotech stain-resistant treatment, in the shade of grey.

Table

Exemplaire énuméré. Structure en Polimex®, revêtu en ciment avec finition acrylique et traitement de protection nano technologique anti-tâche à base de bioxyde de titane, couleur gris.

Tisch

Nummeriertes Exemplar. Gestell aus Polimex®, mit Zement verkleidet, mit Akrylfinish und nanotechnologischer Fleckenschutzbehandlung mit Titandioxid, in der Farbe grau.

Mesa

Pieza numerada. Estructura de Polimex®, revestido en cemento con acabado acrilico y tratamiento de protección nanotecnológico antimancha a base de dióxido de titanio, color gris.

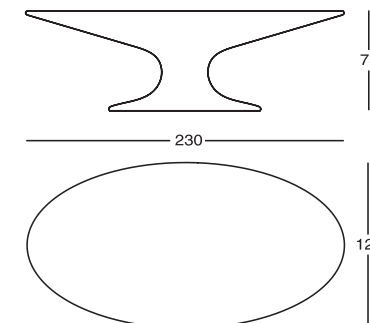

Leonardo ²⁶⁵⁰



Design

Achille Castiglioni

1969

Tavolo da lavoro
Struttura in faggio evaporato, colore naturale. Piano placcato in laminato colore bianco, oppure in cristallo temperato. Regolabile in altezza.

Working table
Natural varnished steam-treated beech trestle. Top coated with white plastic laminate, or with tempered plate glass. Adjustable height.

Table de travail
Structure en hêtre évaporé, couleur naturelle. Plateau plaqué en laminé plastique, couleur blanche, ou en verre trempé. Hauteur réglable.

Arbeitsstisch
Tragböcke aus gedampfter Buche, naturfarben. Platte mit weißem Schichtpreßstoff Laminat beschichtet, oder aus hitzebeständigem Kristallglas. Höhenverstellbar.

Mesa de trabajo
Estructura de haya vaporizada, color natural. Sobre aplacado con laminado, color blanco o de cristal templado. Altura regulable.

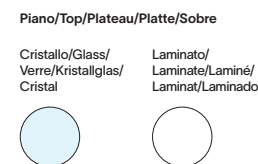
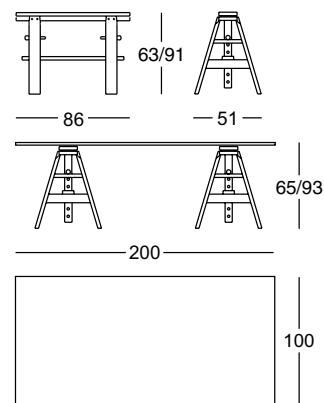

Marcuso ^{2530/2532}



Design

Marco Zanuso

1969-1970

Tavoli
Piano in cristallo trasparente. Gambe in acciaio inox 18/8.

Tables
Clear plate glass top. 18/8 Stainless steel legs.

Tables
Plateau en verre transparent. Pieds en acier inox 18/8.

Tische
Platte aus klarem Kristallglas. Beine aus 18/8 Inox Stahl.

Mesas
Sobre de cristal transparente. Patas de acero inox 18/8.

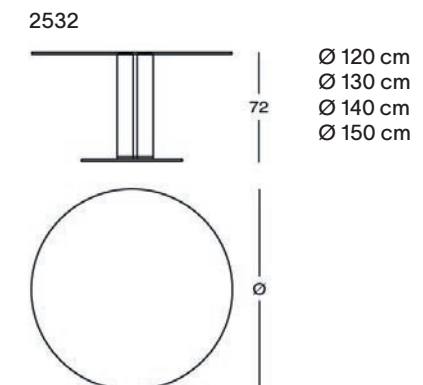
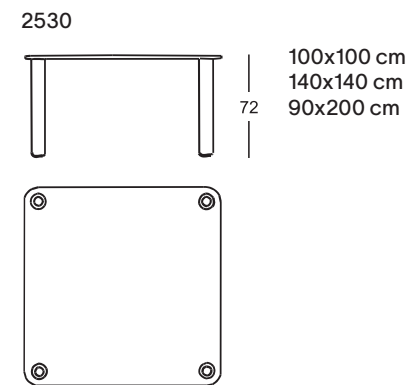

Marcuso ^{2531/2533}



Design

Marco Zanuso

1970

Tavoli
Base e gambe in acciaio verniciato lucido nei colori talco, canapa, alga, amaranto ed espresso, abbinati a piani in marmo Calacatta oppure abbinati a piani in MDF laccati opachi o lucidi negli stessi colori.

Tables
Base and legs in polished varnished steel in talc, hemp, algae, amaranth and espresso matching either the tops in Calacatta marble or the MDF tops, matt or glossy lacquered in the same colours.

Tables
Base et pieds en acier laqué poli dans les couleurs talc, chanvre, algue, amarante et espresso, assortis à des plateaux en marbre Calacatta ou assortis à des plateaux en MDF laqué mat ou brillant dans les mêmes couleurs.

Tische
Untergestell und Beine aus poliertem, lackiertem Stahl in den Farben Talk, Hanf, Alga, Amaranrot und Espresso, kombiniert mit Platten aus Calacatta-Marmor oder mit matt oder glänzend lackierten MDF-Platten in denselben Farben.

Mesas
Base y patas de acero lacado pulido en los colores talco, cáñamo, alga, amaranto y espresso, en combinación con los sobres de mármol Calacatta o los sobres de MDF, lacado mate o brillante en los mismos colores.

2531

2533

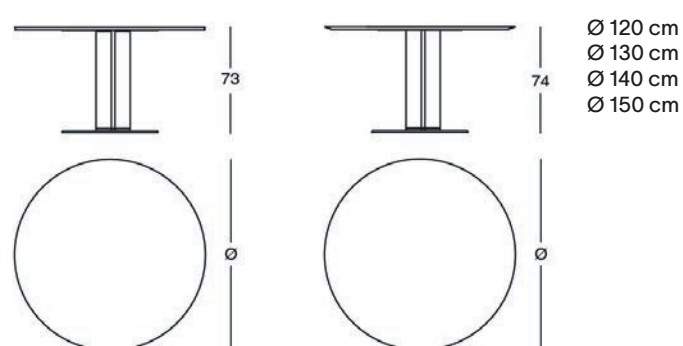

Struttura/Frame/Structure/Gestell/Estructura



Poker ²⁶²⁵



Design

Joe Colombo

1968

Tavolo da gioco
Piani in laminato plastico stratificato, colore bianco. Panno verde con bordo in pelle, amovibile. Gambe in acciaio inox.

Card table
Tops in white layered plastic laminate. Removable, leather trimmed green baize. Stainless steel legs.

Table de jeu
Plateaux en laminé plastique stratifié, couleur blanche. Tapis vert avec bords en cuir, amovible. Pieds en acier inox.

Spieltisch
Tischplatten aus massivem Schichtpreßstoff Laminat, weißfarben. Grünes Filztuch mit Lederrand, abnehmbar. Beine aus Inox-Stahl.

Mesa de juego
Sobres de laminado plástico estratificado, color blanco. Tapete verde extraíble con borde de piel. Patas de acero inox.

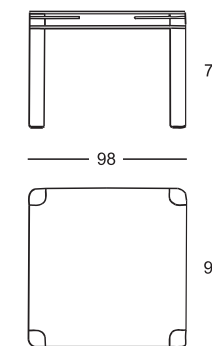

Quaderna Table ²⁶⁰⁰



Design

Superstudio

1969-1972

Tavolo/tavolo scrivania
Struttura in legno tamburato
placcato in laminato Print,
colore bianco, a stampa
digitale a quadretti neri con
interasse di 3 cm.

Table/writing desk
Honeycomb core structure
coated with white plastic
laminates, digitally printed
with black squares at 3 cm
spacing.

Table/table bureau
Structure en panneau
alvéolaire plaqué en Print,
couleur blanche, imprimé en
digital à carrés noirs avec
entraxe de 3 cm.

Tisch/Schreibtisch
Gestell aus Sperrholz
mit weißem Print belegt.
Digitaldruck mit kariertem
Muster, Linienabstand 3 cm.

Mesa/mesa escritorio
Estructura de madera
enchapada aplacada con
laminado Print, color blanco,
a impresión digital en
cuadritos negros de 3 cm.

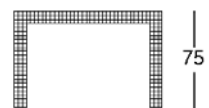

111x111 cm
126x126 cm
90x180 cm

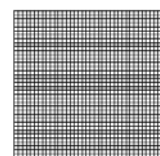

Quaderna Desk ²⁸³⁰

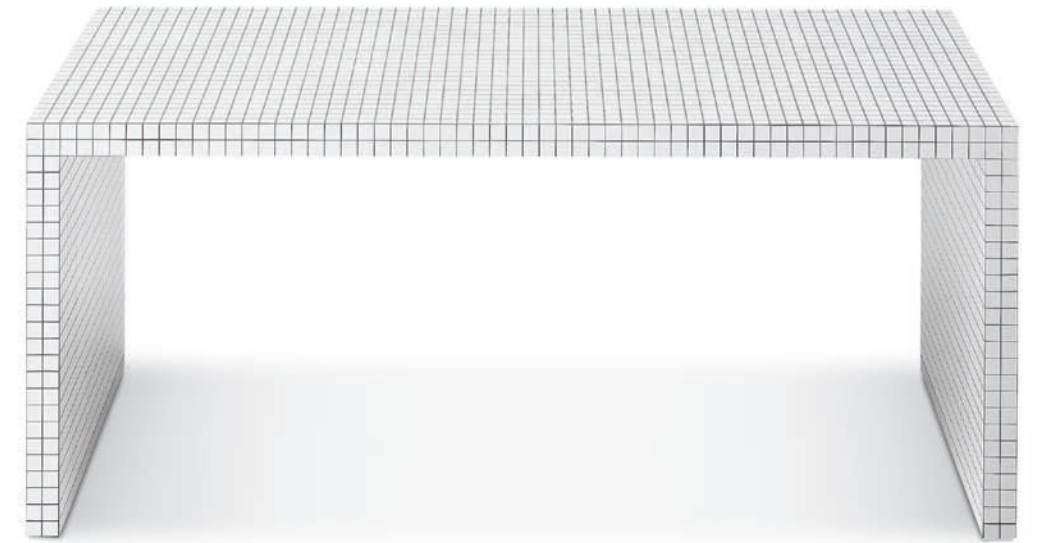

Design

Superstudio

1969-1972

Tavolo/tavolo scrivania
Struttura in legno tamburato
placcato in laminato Print,
colore bianco, a stampa
digitale a quadretti neri con
interasse di 3 cm.

Table/writing desk
Honeycomb core structure
coated with white plastic
laminates, digitally printed
with black squares at 3 cm
spacing.

Table/table bureau
Structure en panneau
alvéolaire plaqué en Print,
couleur blanche, imprimé en
digital à carrés noirs avec
entraxe de 3 cm.

Tisch/Schreibtisch
Gestell aus Sperrholz
mit weißem Print belegt.
Digitaldruck mit kariertem
Muster, Linienabstand 3 cm.

Mesa/mesa escritorio
Estructura de madera
enchapada aplacada con
laminado Print, color blanco,
a impresión digital en
cuadritos negros de 3 cm.

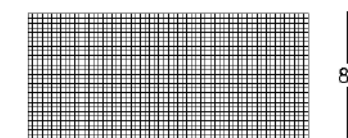
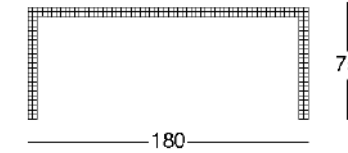

Quaderna Writing Desk ²⁷⁵⁰

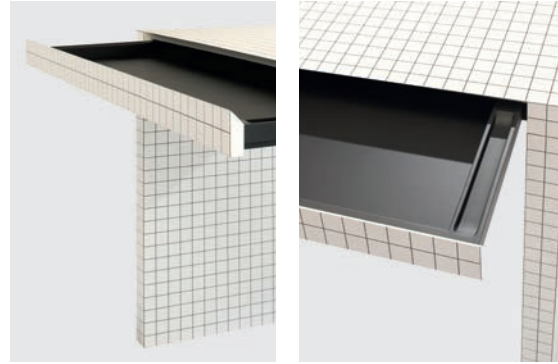

Design

Superstudio

1969-1972

Scrittorio

Struttura in legno tamburato placcato laminato Print, colore bianco, a stampa digitale a quadretti con interasse di 3 cm. Cassetto estraibile a scomparsa ricavato nello spessore del piano, vano cassetto in legno verniciato gofrato antigraffio colore nero.

Desk

Honeycomb core structure coated with white Print laminate, digitally printed with black squares at 3 cm spacing. The top hides a retractable pull-out drawer, with a drawer compartment in black scratch-resistant embossed painted wood.

Bureau

Structure en panneau alvéolaire plaqué en laminé Print, couleur blanche, imprimé en digital à carrés noirs avec entraxe de 3 cm. Tiroir rétractable obtenu dans l'épaisseur du dessus du plateau; compartiment intérieur du tiroir en bois verni gaufré noir résistant aux rayures.

Schreibtisch

Gestell aus Sperrholz mit weißem Print Laminat belegt. Digitaldruck mit kariertem Muster, Linienabstand 3 cm. Eine einziehbare Schublade befindet sich in dem Dicken der Oberplatte mit Schubladenfach aus schwarz kratzfestem und lackiertem Holz.

Escritorio

Estructura de madera aplacada con laminado Print, color blanco, a impresión digital en cuadrillos negros de 3 cm. Cajón retráctil obtenido en el grosor de la parte superior; compartimento del cajón en madera pintada en relieve antirasguño, color negro.

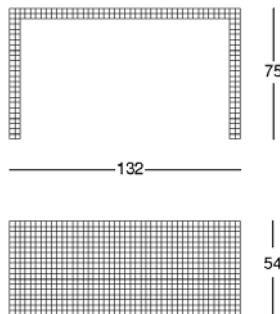

Quaderna Consolle ⁷¹⁰



Design

Superstudio

1969-1972

Consolle

Struttura in legno tamburato placcato in laminato Print, colore bianco, a stampa digitale a quadretti neri con interasse di 3 cm.

Console table

Honeycomb core structure coated with white plastic laminate, digitally printed with black squares at 3 cm spacing.

Console

Structure en panneau alvéolaire plaqué en Print, couleur blanche, imprimé en digital à carrés noirs avec entraxe de 3 cm.

Wandtisch

Gestell aus Sperrholz mit weißem Print belegt. Digitaldruck mit kariertem Muster, Linienabstand 3 cm.

Consola

Estructura de madera aplacada con laminado Print, color blanco, a impresión digital en cuadrillos negros de 3 cm.

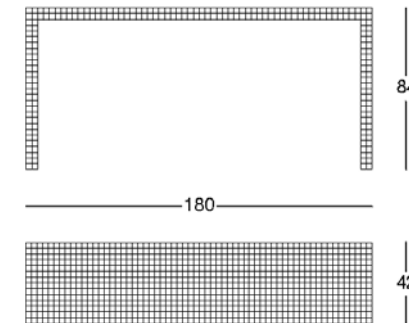

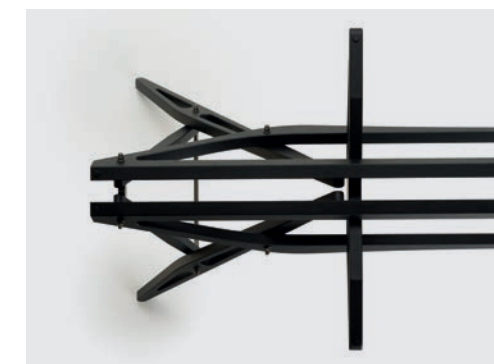

Design

Carlo Mollino

1948

Tavolo

Piano in cristallo trasparente con o senza bordi bisellati, oppure in marmo Emperador, con verniciatura protettiva antimacchia in poliestere trasparente opaco. Struttura in legno massello di rovere naturale o tinto noce Canaletto, oppure tinto arancione o nero; verniciatura con finitura a cera.

Table

Clear plate glass top, with or without bevelled edges or in Emperador marble, with stain-resistant protective varnish, in clear matt polyester. Frame in solid natural or orange or black varnished oak, or in Canaletto walnut-dyed oak; wax-finished varnish.

Table

Plateau en verre transparent avec ou sans bords biseautés, ou en marbre Emperador, avec vernis de protection anti-taches en polyester transparent mat. Structure en rouvre naturel massif ou teinté orange ou noir, ou en rouvre teinté noyer Canaletto; vernis finition cirée.

Tisch

Tischplatte aus transparentem Kristallglas mit oder ohne schräg-abgeschliffenen Rändern, oder aus Emperador Marmor, mit Fleckenschutz-Lackierung aus klarem mattem Polyester. Gestell aus massiver naturfarbener oder orange- oder schwarz gebeizter Eiche oder aus Nussbaum Canaletto gebeizter Eiche; Lackierung mit Wachs-Endbehandlung.

Mesa

Superficie de cristal transparente con o sin borde biselado, o en mármol Emperador, con laca de protección anti mancha en poliéster transparente mate. Estructura de madera maciza de roble natural o teñido naranja o negro o de roble teñido nogal Canaletto; pintura con acabado de cera.

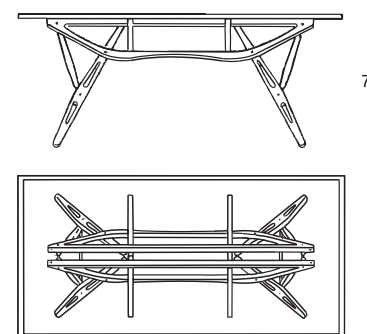

80x160 cm
 90x180 cm
 90x200 cm

Struttura/Frame/Structure/Gestell/Estructura

Rovere naturale/
 Natural oakwood/
 Rouvre naturel/
 Naturfarbene
 Eiche/Roble
 natural



Rovere tinto
 arancione/Orange
 varnished oak/
 Rouvre teinté
 orange/Orange-
 gebeizte Eiche/
 Roble teñido
 naranja



Rovere tinto nero/
 Black varnished
 oak/Rouvre teinté
 noir/Schwarz-
 gebeizte Eiche/
 Roble teñido
 negro



Rovere tinto noce
 Canaletto/Cana-
 letto walnut dyed
 oak/Rouvre teinté
 noyer Canaletto/
 Nussbaum Cana-
 letto gebeizte
 Eiche/Roble teñido
 nogal Canaletto



Piano/Top/Plateau/Platte/Sobre

Cristallo
 trasparente/
 Transparent/
 plate glass/Verre
 transparent/
 Transparentes
 Kristallglas/Cristal
 transparente



Marmo
 Emperador/
 Emperador
 marble/Marbre
 Emperador/
 Emperador/
 Marmor/Marmól
 Emperador



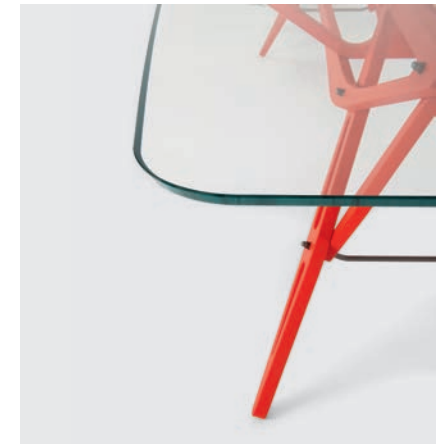
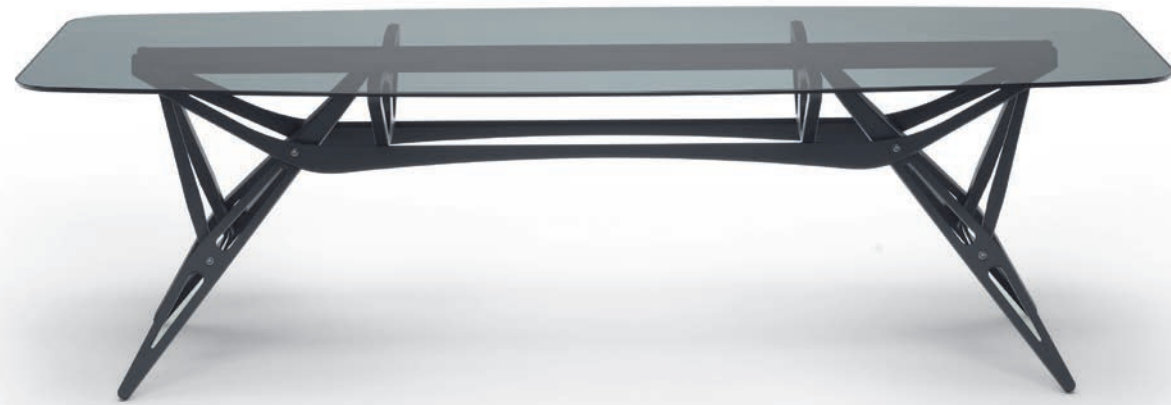

Design

Carlo Mollino

1948

Tavolo

Struttura in legno massello di rovere naturale o tinto arancione o nero oppure in legno massello di noce Canaletto colore naturale; verniciatura con finitura a cera. Piano in cristallo extra-chiaro con bordo a taglio inclinato, oppure in cristallo fumè grigio con bordo a taglio inclinato, in abbinamento alla struttura in rovere tinto nero.

Table

Frame in solid natural or orange or black varnished oak, or in solid natural Canaletto walnut; wax-finished varnish. Extra clear plate glass top, with inclined cut edges, or smoky grey plate glass top, with inclined cut edges, matching the black oak frame.

Table

Structure en rouvre naturel massif ou teinté orange ou noir ou en noyer Canaletto massif, couleur naturelle; verni finition cirée. Plateau en verre extra-clair à bord coupé oblique, ou en verre gris fumé à bord coupé oblique, en combinaison avec la structure en rouvre teinté noir.

Tisch

Gestell aus massiver naturfarbener oder orange- oder schwarz gebeizter Eiche, oder aus massivem naturfarbenem Nussbaum Canaletto. Lackierung mit Wachs-Endbehandlung. Tischplatte aus extra-klarem Kristallglas, mit geneigten geschnittenen Rändern, oder aus grau rauchfarbenem Kristallglas mit geneigten geschnittenen Rändern, passend zu dem Gestell aus schwarz gebeizter Eiche.

Mesa

Estructura de madera maciza de roble natural o teñido naranja o negro o de madera maciza de nogal Canaletto color natural; pintura con acabado de cera. Superficie de cristal extra claro con borde de corte inclinado, o de cristal gris humo con borde de corte inclinado, combinado con la estructura en roble teñido negro.

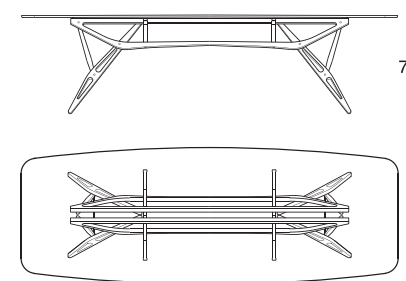

90x220 cm
 100x250 cm
 100x280 cm

Struttura/Frame/Structure/Gestell/Estructura

Rovere naturale/
 Natural oakwood/
 Rouvre naturel/
 Naturfarbene
 Eiche/Roble
 natural



Rovere tinto
 arancione/Orange
 varnished oak/
 Rouvre teinté
 orange/Orange-
 gebeizte Eiche/
 Roble teñido
 naranja



Rovere tinto nero/
 Black varnished
 oak/Rouvre teinté
 noir/Schwarz-
 gebeizte Eiche/
 Roble teñido
 negro



Noce Canaletto/
 Canaletto walnut/
 Noyer Canaletto/
 Nussbaum
 Canaletto/Nogal
 Canaletto



Piano/Top/Plateau/Platte/Sobre

Cristallo extra-
 chiaro/Extra-clear
 plate glass/Verre
 extra-clair/Extra-
 klares Kristallglas/
 Cristal extra-claro



Cristallo fumé
 grigio/Smoky
 grey plate glass/
 Verre gris fumé/
 Rauchfarbenes
 Kristallglas/Cristal
 gris humo



Riga–Riga ²⁶⁹¹



Design

Pierre Charpin

2025

Tavolo
Piano in legno tamburato impiallacciato in frassino laccato poro aperto colore nero o amaranto. Inserti in cristallo retro verniciato colore menta e cielo per la versione nera o avorio e corallo per la versione amaranto. Gambe in multistrati curvato, impiallacciate in frassino laccato poro aperto colore nero o amaranto.

Table
Honeycomb-core wood top, veneered with open-pore lacquered ash in black or amaranth. Back-painted glass inserts in mint and sky colour for the black version or ivory and coral for the amaranth version. Legs in curved plywood, veneered in open-pore lacquered ash in black or amaranth.

Table
Plateau en bois alvéolaire plaqué frêne laqué pore ouvert noir ou amarante. Inserts en verre rétro-peint couleur menthe et ciel pour la version noire, ou ivoire et corail pour la version amarante. Pieds en contreplaqué courbé, plaqué en frêne laqué pore ouvert noir ou amarante.

Tisch
Platte Sperrholz, in schwarz oder Amaranthrot offenporig lackierter Esche furniert. Hinterlackierte Kristallgaseinsätze Mint und himmelblau für die schwarze Version oder Elfenbein und Koralle für die Amaranthrot-Version. Beine aus gebogenem Sperrholz, offenporig lackiert Esche furniert in schwarz oder Amaranthrot.

Mesa
Sobre en madera alveolar chapado en fresno lacado a poro abierto negro o granate. Inserciones de cristal pintadas por detrás en color menta y cielo para la versión negra, o marfil y coral para la versión granate. Patas en contrachapado curvado, chapadas en fresno lacado a poro abierto en negro o granate.

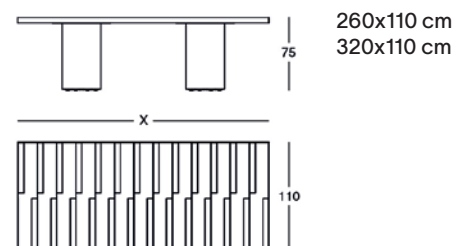

Tidone ²⁷⁶⁰



Design

Calvi Brambilla

2024

Tavolo
Piano in legno tamburato, con anima in alveolare di alluminio, impiallacciato in frassino tinto poro aperto colore alga, amaranto, espresso o nero, oppure frassino tinto rovere. Gambe in legno massello di frassino tinto negli stessi colori del piano. È data la possibilità di scegliere il posizionamento delle gambe, se a filo del piano oppure leggermente arretrate.

Table
Honeycomb wood top, with aluminium honeycomb core, veneered with open pore stained ash in the colours algae, amaranth, espresso or black or in oak stained ash. Legs made of solid stained ash in the same colours as the top. We offer the possibility to position the legs either flush with the top or slightly back.

Table
Plateau en bois alvéolaire, avec âme en aluminium alvéolaire, plaqué en frêne teinté à pore ouvert dans les couleurs algues, rouge amarante, espresso ou noir ou frêne teinté rouvre. Pieds en frêne massif teinté dans les mêmes couleurs que le plateau. Il est possible de choisir la position des pieds, qu'ils soient au ras du plateau ou légèrement en retrait.

Tisch
Platte aus Sperrholz mit Aluminiumwabenkern, furniert mit offenporig gebeizter Esche in den Farben Algen, Amaranthrot, Espresso oder schwarz oder mit Eiche gebeizter Esche. Beine aus massiver Esche, gebeizt in denselben Farben wie die Platte. Es ist möglich, die Position der Beine zu wählen, ob bündig mit der Platte oder leicht zurückgesetzt.

Mesa
Sobre de madera alveolar, con anima alveolar de aluminio, chapado en fresno teñido a poro abierto en los colores alga, granate, espresso o negro o fresno teñido roble. Patas de fresno macizo teñido en los mismos colores del sobre. Es posible elegir la posición de las patas, a ras de el sobre o ligeramente retranqueadas.

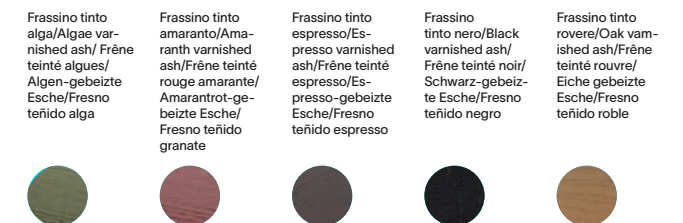
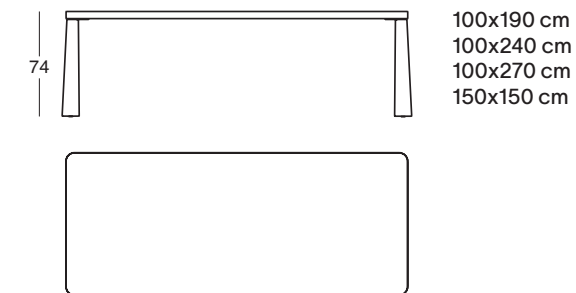



Design

Garcia Cumini

2017

Tavolo

Piano in legno placcato in rovere, verniciato colore naturale, con sottopiano verniciato colore grigio, o a poro aperto colore nero, con sottopiano verniciato colore nero, oppure in noce Canaletto, verniciato colore naturale, con sottopiano verniciato colore nero. Gambe in abbinamento rispettivamente in legno massello di rovere verniciato colore naturale, o di rovere verniciato a poro aperto nero, oppure di noce Canaletto, verniciato colore naturale. Piedino regolabile in alluminio verniciato nero.

Table

Top available either in natural painted oak veneered wood, with grey painted under-top, or black painted with an open pore, with black painted under-top or in natural painted Canaletto walnut veneered wood, with black painted under-top. Legs are available respectively in natural painted solid oak, or in open pore black painted oak, or in natural painted Canaletto walnut. Black painted aluminium adjustable foot.

Table

Plateau en bois plaqué dans la finition rouvre, verni couleur naturel, avec un sous-plateau verni gris, ou verni à pore ouvert noir avec sous-plateau verni noir, ou plaqué en noyer Canaletto, verni couleur naturel avec un sous-plateau verni noir. Pieds en combinaison respectivement en bois massif de rouvre, verni couleur naturel, ou en rouvre verni à pore ouvert noir, ou en noyer Canaletto, verni couleur naturel. Petit pied réglable en aluminium verni noir.

Tisch

Holzplatte furniert mit naturfarben lackierter Eiche, mit grau lackierter Unterplatte, oder schwarz lasiert mit schwarz lackierter Unterplatte, oder mit naturfarben lackiertem Nussbaum Canaletto, mit schwarz lackierter Unterplatte. Beine aus massiver Eiche, naturfarben lackiert, oder bzw. aus schwarz lasierter Eiche oder bzw. aus Nussbaum Canaletto, naturfarben lackiert. Verstellbarer Fuß aus schwarz lackiertem Aluminium.

Mesa

Superficie de madera chapada en roble barnizado natural, con la parte inferior pintada de color gris, o pintado a poro abierto, color negro, con la parte inferior pintada de color negro, o en nogal Canaletto barnizado natural, con la parte inferior pintada de color negro. Patas combinadas respectivamente en madera maciza de roble, barnizado natural, o de roble pintado a poro abierto negro, o de nogal Canaletto barnizado natural. Pie regulable en aluminio pintado negro.

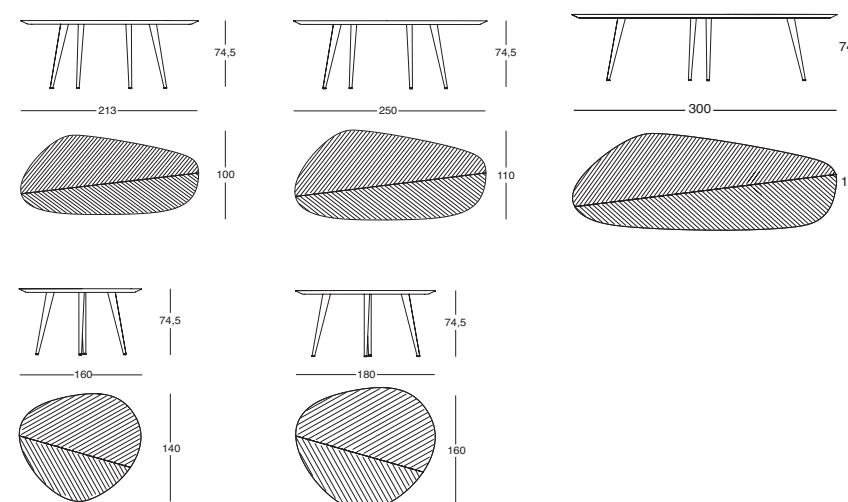

Piano/Top/Plateau/Platte/Sobre

Rovere naturale/ Natural oakwood/ Rouvre naturel/ Naturfarbene Eiche/Roble natural	Rovere tinto nero/ Black varnished oak/Rouvre teinté noir/Schwarz- gebeizte Eiche/ Roble teñido negro	Noce Canaletto/ Canaletto walnut/ Noyer Canaletto/ Nussbaum Canaletto/Nogal Canaletto
---	---	--



Tweed 2319



Design

Garcia Cumini

2017

Tavolo
Piano in MDF laccato opaco colore canapa, amaranto, espresso e nero. Gambe in legno laccate nei medesimi colori dei piani. Piedini regolabili in alluminio verniciato nero.

Table
MDF top, matt lacquered in the colours hemp, amaranth, espresso and black. Legs lacquered in the same colours as the top. Black painted aluminium adjustable feet.

Table
Plateau en MDF, vernis mat dans les couleurs chanvre, rouge amarante, espresso et noir. Pieds laqués dans les memes couleurs du plateau. Petites pieds réglables en aluminium verni noir.

Tisch
MDF-Platte, matt lackiert in den Farben Hanf, Amaranth, Espresso und schwarz. Beine lackiert in denselben Farben wie die Platte. Verstellbare Füße aus schwarz lackiertem Aluminium.

Mesa
Sobre de MDF, lacado mate en los colores cáñamo, granate, espresso y negro. Patas lacadas en los mismos colores del sobre. Pies regulables en aluminio pintado negro.

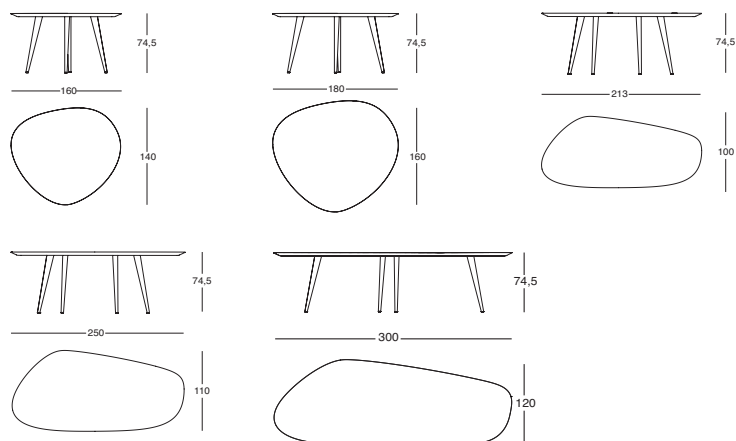

Struttura/Frame/Structure/Gestell/Estructura



Tweed Marble 2318



Design

Garcia Cumini

2023

Tavolo
Piano in marmo Striato Olimpico con verniciatura protettiva antimacchia in poliestere trasparente opaca. Sotto piano in MDF laccato colore nero opaco. Gambe in tubolare di acciaio verniciato colore nero opaco.

Table
Top in Striato Olimpico marble with stain resistant protective varnish in clear matt polyester. MDF under-top, lacquered matt black. Legs in matt black painted tubular steel.

Table
Plateau en marbre Striato Olimpico, vernis de protection anti-taches en polyester transparent mat. Sous-plateau en MDF, laqué noir mat. Pieds en tube d'acier verni noir mat.

Tisch
Platte aus Striato Olimpico-Marmor, mit Fleckenschutz Lackierung aus transparentem matten Polyester. Unterplatte aus matt schwarz lackiertem MDF. Beine aus matt schwarz lackiertem Stahlrohr.

Mesa
Sobre de mármol Striato Olimpico, con laca de protección antimancha, en poliéster opaco transparente. Parte inferior de MDF lacado en negro mate. Patas de tubo de acero pintadas en negro mate.

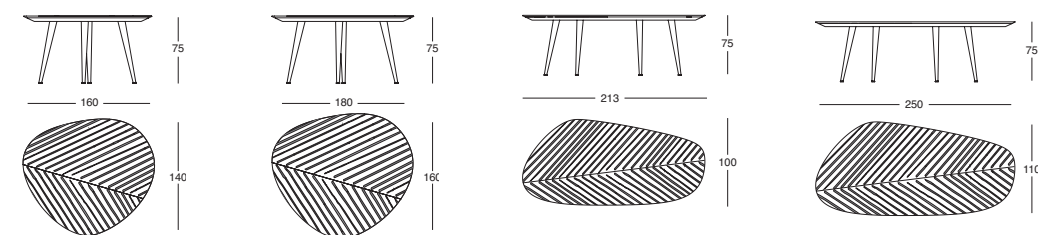



Design

Carlo Mollino

1950

Tavoli
 Piano in cristallo extra-chiaro temperato. Struttura in multistrato placcato rovere con vertebre reggi cristallo in legno massello di rovere colore naturale o tinto nero; verniciatura con finitura a cera. Tiranti e piedini in acciaio nichelsatinato colore nero opaco.

Table
 Extra-clear tempered plate glass top. Frame in oak-veneered plywood with glass support struts in solid oak, either natural or black-stained; finished with a wax coating. Tie rods and feet in matt black nickel-plated steel.

Table
 Plateau en verre trempé extra-clair. Structure en contreplaqué plaqué rouvre avec montants en rouvre massif naturel ou teinté noir; finition vernie à la cire. Tiges et pieds en acier nickelé satiné, couleur noir mat.

Tisch
 Tischplatte aus extra-klarem, gehärtetem Kristallglas. Gestell aus Eichenfurnier-Sperrholz mit Glasstützen aus massiver Eiche, naturfarben oder schwarz gebeizt; Lackierung mit Wachsfinish. Zugstangen und Tischfüße aus mattschwarzem, satinierem und vernickeltem Stahl.

Mesa
 Sobre de cristal templado extra-claro transparente. Estructura de contrachapado chapado en roble con soportes de cristal de roble macizo, en color natural o teñido negro; pintura con acabado de cera. Barras de tracción y patas de acero negro mate, satinado y niquelado.

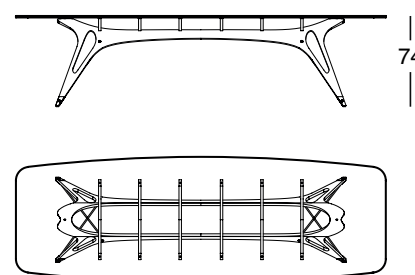

300x102cm
 320x102cm

Struttura/Frame/Structure/Gestell/Estructura

Rovere naturale/
 Natural oakwood/
 Rouvre naturel/
 Naturfarbene
 Eiche/Roble
 natural

Rovere tinto nero/
 Black varnished
 oak/Rouvre teinté
 noir/Schwarz-
 gebeizte Eiche/
 Roble teñido
 negro



Zavolo Console ⁷⁹²



Design

Zaven

2024

Console

Struttura in MDF, laccatura opaca nei colori talco, cera, canapa, caramello, arancione, amaranth, verde prato, alga, espresso e nero. Prevede il fissaggio a parete.

Console table

MDF frame, matt lacquered in the colours talc, wax, hemp, caramel, orange, amaranth, grass green, algae, espresso and black. Must be fastened to wall.

Console

Structure en MDF, laquée mat dans les couleurs talc, cire, chanvre, caramel, orange, rouge amarante, vert pré, algues, espresso et noir. Il prévoit le montage mural.

Wandtisch

Gestell aus MDF, matt lackiert in den Farben Talkum, Wachs, Hanf, Karamell, Orange, Amaranthrot, grasgrün, Algen, Espresso und schwarz. Für die Wandmontage vorgesehen.

Consola

Estructura de MDF, lacado mate en los colores talco, cera, cáñamo, caramelo, naranja, granate, verde prado, alga, espresso y negro. Debe ser fijada a la pared.

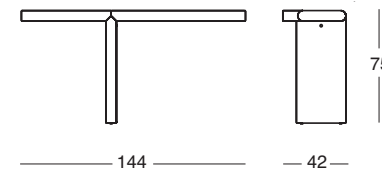

Struttura/Frame/Structure/Gestell/Estructura





Beds, Mattresses, Springing

Letti,
materassi, reti
Lits, matelas,
sommiers
Betten,
Matratzen,
Lattenroste
Camas,
colchones,
somieres

184–201

Grangala ¹⁸⁷⁹



Design

Gabriele Rosa

2018

Letti con rete unica o separata

Piedini e mensole in acciaio rivestiti in cuoio pigmentato 90 nel medesimo colore. Struttura in acciaio con doghe in faggio curvato, verniciato naturale. Imbottitura testiera e base in poliuretano/fibra poliestere termolegata. Rivestimento, sfilabile, in stoffa o pelle. A richiesta sono disponibili le misure per i materassi da 210 e 220 cm di lunghezza ed è possibile rivestire interamente il retro della testiera nel medesimo tessuto o pelle del letto.

Beds with single or separate springing

Steel feet and shelves covered with cowhide pigmentato 90 in the same colour. Steel frame with suspension on natural bent beech strips. Base and headboard upholstered in polyurethane/heat bound polyester fibre. Removable fabric or leather cover. Upon request the bed sizes for 210 cm. and 220 cm. long mattresses are available, as well as the headboard can be fully covered with the same fabric or leather of the bed.

Lits avec sommier single ou séparé

Pieds et étagère en acier recouverts en cuir sellier pigmentato 90 dans la même couleur. Structure en acier avec douves en hêtre courbé, verni naturel. Cadre et tête de lit rembourrés en polyuréthane/fibre polyester liée à chaud. Revêtement déhoussable en tissu ou en cuir. Sur demande, il sont prévus les mesures pour des matelas de 210 cm. et 220 cm de longueur et il est possible de couvrir complètement le dos de la tête de lit avec le même tissu ou cuir que le lit.

Betten mit einzelner oder getrenntem Lattenrost

Stahl-Füße und Stützfläche bezogen mit Kernleder pigmentato 90 in der derselben Farbe. Stahl-Gestell mit gebogenen Buchen-Dauben, naturfarben lackiert. Kopfteil und Unterteil mit Polyurethan/wärmegebundener Polyesterfaser gepolstert. Abnehmbarer Bezug aus Stoff oder Leder. Auf Nachfrage sind die Bett-Maßen für die Matratzen 210 cm und 220 cm lang verfügbar und kann das ganze Kopfteil in dem gleichen Stoff oder Leder des Bettes bezogen werden.

Camas con somier unico o separado

Patas y repisa de acero tapizados de cuero pigmentato 90 del mismo color. Estructura de acero con lamas de haya curvada, barnizado natural. Base y cabezal acolchados de poliuretano/fibra poliéster termounida. Tapizado desenfundable de tejido o de piel. Sobre pedido están disponibles las medidas de la cama para colchones de 210 cm y 220 cm de largo; es posible también tapizar completamente la parte trasera del cabezal con el mismo tejido o piel de la cama.

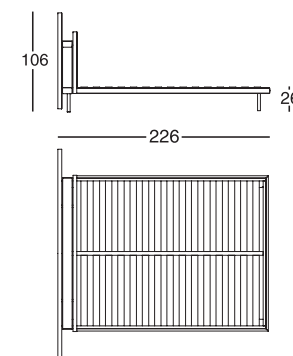

Dimensioni/Sizes/Dimensions/Abmessungen/Medidas

195x226 cm (140x200 cm)*
221x226 cm (160x200 cm)*
235x226 cm (170x200 cm)*
240x226 cm (180x200 cm)*

* Dimensioni del materasso/Mattress sizes/ Dimensions du matelas/ Abmessungen der Matratze/Medidas del colchón



Design

De Pas, D'Urbino, Lomazzi

1983

Letto

Struttura in acciaio con doghe in faggio curvato. Piedini in acciaio nichelsatinato colore naturale o nero che permettono di ottenere diverse altezze del letto. Rivestimento sfilabile, in tessuto o pelle o non sfilabile in cuoio. La versione in cuoio ha le cuciture in filo bianco. A richiesta è disponibile anche la misura per il materasso da 210 cm di lunghezza.

Bed

Steel frame with bent beech strips. Steel feet, with natural or black nickel-satin finish that allow different heights of the bed. Removable fabric or leather cover, or non-removable in cowhide. The version in cowhide has the stitching in white thread. Upon request the bed size for 210 cm. long mattress is also available.

Lit

Structure en acier avec douves en hêtre courbé. Pieds en acier nickel satiné, dans les couleurs naturel ou noir que permettent d'obtenir différentes hauteurs du lit. Revêtement déhoussable, en tissu ou cuir ou non déhoussable en cuir sellier. La version en cuir sellier a les coutures en fil blanc. Sur demande, il est prévu aussi la mesure pour un matelas de 210 cm de longueur.

Bett

Stahlgestell mit Lattenrost aus gebogenen Buchen-Dauben. Füße aus Stahl mit naturfarben- oder schwarz- vernickeltem und mattiertem Finish, die verschiedene Betthöhen erlauben. Abnehmbarer Bezug aus Stoff oder Leder oder nicht abziehbare aus Kernleder. Die Nähte der Kernlederausführung sind weiß. Auf Nachfrage ist die Bett- Maße für die Matratze 210 cm lang auch verfügbar.

Cama

Estructura de acero con lamas de haya curvadas. Pies de acero niquelado mate en los acabados natural o negro que permiten diferentes alturas de la cama. Tapizado de tejido o de piel, desenfundable, o de cuero, fijo. La versión en cuero tiene las costuras en hilo blanco. Sobre pedido está también disponible la medida de la cama para el colchón de 210 cm de largo.

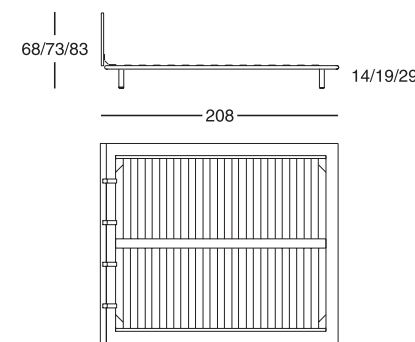

Dimensioni/Sizes/Dimensions/Abmessungen/Medidas

93x208 cm (90x200 cm)*
143x208 cm (140x200 cm)*
163x208 cm (160x200 cm)*
183x208 cm (180x200 cm)*
203x208 cm (200x200 cm)*

* Dimensioni del materasso/Mattress sizes/ Dimensions du matelas/ Abmessungen der Matratze/Medidas del colchón

Piedini/Feet/Pieds/Füße/Patas





Design

Simone Bonanni

2026

Letto

Gambe in legno massello di frassino tinto rovere o tinto moka o laccato poro aperto nei colori talco, amaranto e nero. Barra reggi testiera posteriore in acciaio verniciata colore nero opaco. Struttura in acciaio con doghe in faggio curvato, verniciato naturale. Imbottitura testiera a quote differenziate di poliuretano CIRCULARREFOAM® composto da una percentuale di polioli riciclati/ fibra in PET con una percentuale di riciclato post-consumo. Rivestimento sfilabile in stoffa o in pelle.

Bed

Legs in solid oak - or mocha varnished ash, or open-pore lacquered in talc, amaranth and black. Rear backrest support bar in matt black painted steel. Steel frame with suspension in natural varnished bent beech strips. Headboard padding in CIRCULARREFOAM® polyurethane of varying densities composed of a percentage of recycled polyols/PET fibre including a percentage of post-consumer recycled material. Removable external cover in fabric or leather.

Lit

Pieds en frêne massif teinté rouvre ou moka, ou laqués à pores ouverts dans les couleurs talc, rouge amarante et noir. Barre de soutien arrière du dossier en acier verni noir mat. Structure en acier avec douves en hêtre courbé, verni naturel. Rembourrage de la tête de lit en polyuréthane CIRCULARREFOAM® à densités variables, composé d'un pourcentage de polyols recyclés/fibres de PET, dont une partie provient de matériaux recyclés post-consommation. Revêtement extérieur déhoussable en tissu.

Bett

Beine aus massiver Esche, gebeizt in Eiche oder Mokka oder offenporig lackiert in den Farben Talkum, Amaranthrot und Schwarz. Hintere Rückenlehnenstütze aus mattschwarz lackiertem Stahl. Stahlgestell mit Lattenrost aus gebogenen Buchendauben, naturfarben. Polsterung vom Kopfteil aus CIRCULARREFOAM®-Polyurethan mit unterschiedlichen Dichten, das einen Anteil an recycelten Polyölen und PET-Fasern enthält, darunter auch ein Anteil an Post-Consumer-Recyclingmaterial. Abnehmbarer Außenbezug aus Stoff oder Leder.

Cama

atas de madera maciza de fresno teñida en roble o moka, o lacada con poro abierto en los colores talco, granate y negro. Barra de soporte trasera del respaldo en acero pintado en negro mate. Estructura de acero con somier con lamas de haya curvadas, de color natural. Cabezal acolchado con densidades diferenciadas de poliuretano CIRCULARREFOAM®, compuesto por un porcentaje de polioles reciclados/fibra de PET con un porcentaje de material reciclado postconsumo. Tapizado exterior desenfundable de tejido o piel.

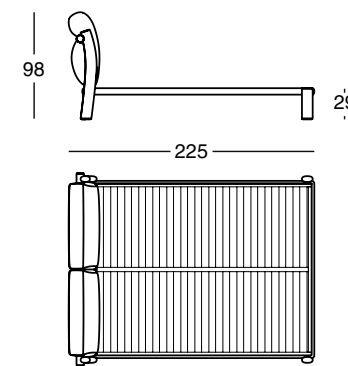

Dimensioni/Sizes/Dimensions/Abmessungen/Medidas

- 185x225cm (160x200 cm)*
- 195x225cm (170x200 cm)*
- 205x225cm (180x200 cm)*
- 225x225cm (200x200 cm)*

* Dimensioni del materasso/Mattress sizes/ Dimensions du matelas/ Abmessungen der Matratze/Medidas del colchón

Struttura/Frame/Structure/Gestell/Estructura





Design

Emaf Progetti

2010

Letti

Struttura smontabile in acciaio verniciato, colore talco o nero. Molleggio in doghe di faggio curvato con regolatori di rigidità. La versione 1707 è dotata di cuscini testiera in piuma d'oca – materiale 100% vergine con inserto in poliuretano. Rivestimento sfilabile in stoffa o pelle (solo per il mod. 1707). A richiesta è disponibile anche la misura per il materasso da 210 cm di lunghezza.

Beds

Demountable steel frame painted in the shade of talc or black. Springing in bent beech strips, with stiffness adjusters. Version 1707 has headboard cushions with goose down – 100% pure material, with polyurethane insert. Removable fabric or leather cover (only for model 1707). Upon request the bed size for 210 cm. long mattress is also available.

Lits

Structure démontable en acier laqué, talc ou noire. Suspension en douves de hêtre courbé, avec régulateurs de rigidité. Dans la version 1707, les coussins à la tête du lit sont en plumes d'oie – matériau 100 % vierge, avec insert en polyuréthane. Revêtement déhoussable en tissu ou en cuir (seulement pour le modèle 1707). Sur demande, il est prévu aussi la mesure pour un matelas de 210 cm de longueur.

Betten

Zerlegbares Gestell aus Talkum- oder schwarz lackiertem Stahl. Lattenrost aus gebogenen Buchen-Dauben, in der Nachgiebigkeit regulierbar. Bei der Ausführung 1707 sind die Kissen des Kopfteils mit 100% reinen Gänsedaunen gefüllt, mit Einlage aus Polyurethan. Abnehmbarer Bezug aus Stoff oder Leder (nur fürs Modell 1707). Auf Nachfrage ist die Bett-Maße für die Matratze 210 cm lang auch verfügbar.

Camas

Estructura desmontable de acero barnizado, color talco o negro. Somier con lamas de haya curvadas, con reguladores de rigidez. La versión 1707 está dotada de cojines de cabezal en plumón de ganso – material 100% virgen con inserción de poliuretano. Tapizado desenfundable en tejido o piel (solo por el modelo 1707). Sobre pedido está también disponible la medida de la cama para el colchón de 210 cm de largo.

1706

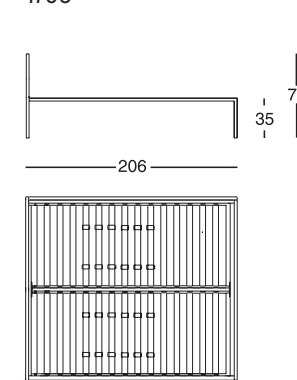

1707

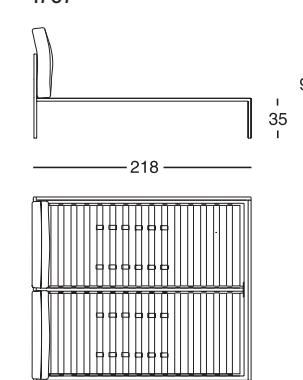

Dimensioni/Sizes/Dimensions/Abmessungen/Medidas

Mod. 1706	Mod. 1707
96x206 cm (90x200 cm)*	96x218 cm (90x200 cm)*
146x206 cm (140x200 cm)*	146x218 cm (140x200 cm)*
166x206 cm (160x200 cm)*	166x218 cm (160x200 cm)*
186x206 cm (180x200 cm)*	186x218 cm (180x200 cm)*
206x206 cm (200x200 cm)*	206x218 cm (200x200 cm)*

* Dimensioni del materasso/Mattress sizes/Dimensions du matelas/Abmessungen der Matratze/Medidas del colchón

Struttura/Frame/Structure/Gestell/Estructura





Design

Spalvieri & Del Ciotto

2020

Letti con rete unica o separata

Struttura testiera in rovere naturale o verniciato a poro aperto colore nero. Imbottitura in poliuretano/ fibra poliestere termolegata. Piedi anteriori e asta superiore testiera in acciaio verniciato colore nero opaco. Rivestimento sfilabile in stoffa o pelle. Struttura base in acciaio con doghe in faggio curvato verniciato naturale. A richiesta è disponibile anche la misura per il materasso da 210 cm di lunghezza.

Beds with single or separate springing

Headboard frame in natural or in black open pore painted oak. Upholstery in polyurethane/heat-bound polyester fibre. Front feet and headboard upper rod in matt black varnished steel. Removable fabric or leather cover. Steel base with natural bent beech strips. Upon request the bed size for 210 cm long mattress.

Lits avec sommier single ou séparé

Structure tête et pied du lit en rovere naturel ou verni à pore ouvert, dans la couleur noire. Rembourrage en polyuréthane/fibre polyester liée à chaud. Pieds avant et tête de lit supérieure en acier peint en noir mat. Revêtement déhoussable en tissu ou en cuir. Structure en acier avec douves en hêtre courbé verni naturel. Sur demande il est possible de commander le lit pour le matelas en longueur de 210 cm.

Betten mit einzelner oder getrenntem Lattenrost

Kopfteil aus naturfarbener oder schwarz lasierter Eiche. Polsterung aus Polyurethan/ wärmegebundener Polyesterfaser. Vordere Füße und obere Stange des Kopfteils aus mattem schwarz lackiertem Stahl. Abnehmbarer Bezug aus Stoff oder Leder. Unterteil-Gestell aus Stahl mit Lattenrost aus gebogenen Buchen-Dauben, naturfarben lackiert. Auf Nachfrage sind die Bett-Maße für die Matratze 210 cm lang verfügbar.

Cama con somier unico o separado

Estructura cabezal y pies en roble natural o lacado a poro abierto color negro. Acolchado de poliuretano/ fibra de poliéster termounida. Patas anteriores y varilla superior del cabezal en acero pintado color negro mate. Tapizado desenfundable de tejido o piel. Estructura de acero con lamas de haya curvada, barnizado natural. Sobre pedido la cama puede realizarse para alojar un colchón de 210 cm de largo.

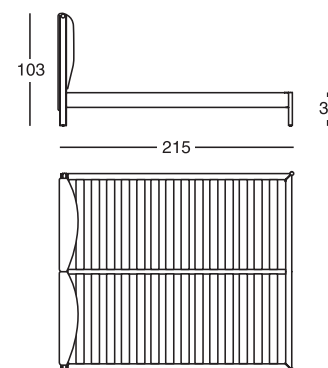

Dimensioni/Sizes/Dimensions/Abmessungen/Medidas

173x215 cm (160x200)*
183x215 cm (170x200)*
193x215 cm (180x200)*

* Dimensioni del materasso/Mattress sizes/ Dimensions du matelas/ Abmessungen der Matratze/Medidas del colchón

Struttura/Frame/Structure/Gestell/Estructura

Rovere naturale/Natural oakwood/
Rouvre naturel/Naturfarbene Eiche/
Roble natural



Rovere tinto nero/Black varnished oak/
Rouvre teinté noir/Schwarz-gebeizte
Eiche/Roble teñido negro



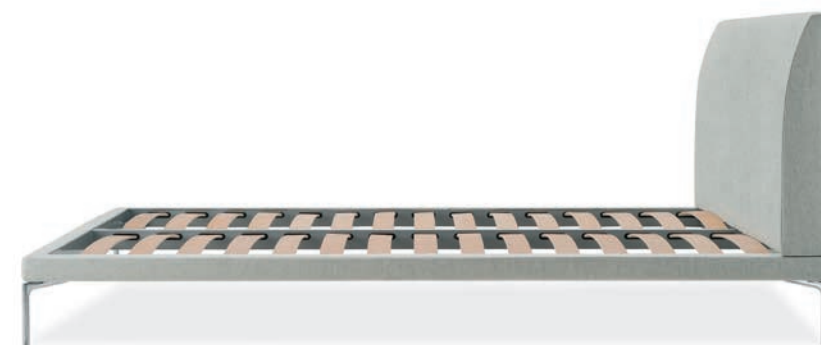

Design

Damian Williamson

2011

Letti con rete unica o separata

Piedini in lega di alluminio lucidato o nichelsatinato colore naturale o nero, oppure verniciato nero. Struttura in acciaio con doghe in faggio curvato. Imbottitura testiera in poliuretano/fibra poliestere termolegata. Rivestimento sfilabile in stoffa o pelle. A richiesta sono disponibili anche le misure per i materassi da 210 e 220 cm di lunghezza.

Beds with single or separate springing

Polished or black painted aluminium alloy feet, or with natural or black nickel-satin finish. Steel frame with suspension in bent beech strips. Headboard upholstered with polyurethane/heat-bound polyester fibre. Removable fabric or leather cover. Upon request the bed sizes for 210 cm. and 220 cm. long mattresses are also available.

Lits avec sommier single ou séparé

Pieds en alliage d'aluminium poli ou nickel satiné, dans les couleurs naturel ou noir, ou verni noir. Structure en acier avec douves en hêtre courbé. Rembourrage de la tête de lit en polyuréthane/fibre polyester liée à chaud. Revêtement déhoussable en tissu ou en cuir. Sur demande, ils sont prévus aussi les mesures pour des matelas de 210 cm. ou 220 cm. de longueur.

Betten mit einzelner oder getrenntem Lattenrost

Füße aus polierter oder schwarz-lackierter Aluminiumlegierung oder mit naturfarben- oder schwarz-vernickeltem und mattiertem Finish. Stahlgestell mit gebogenen Buchen-Dauben. Kopfteilpolsterung aus Polyurethan/ wärmegebundener Polyesterfaser. Abnehmbarer Bezug aus Stoff oder Leder. Auf Nachfrage sind die Bett-Maßen für die Matratzen 210 cm und 220 cm lang auch verfügbar.

Cama con somier unico o separado

Pies de aleación de aluminio pulido o niquelado mate en los acabados natural o negro, o pintado negro. Estructura de acero con lamas de haya curvada. Cabezal acolchado de poliuretano/fibra poliéster termounida. Tapizado desenfundable, de tejido o de piel. Sobre pedido están tambien disponibles las medidas de la cama para colchones de 210 cm y 220 cm de largo.

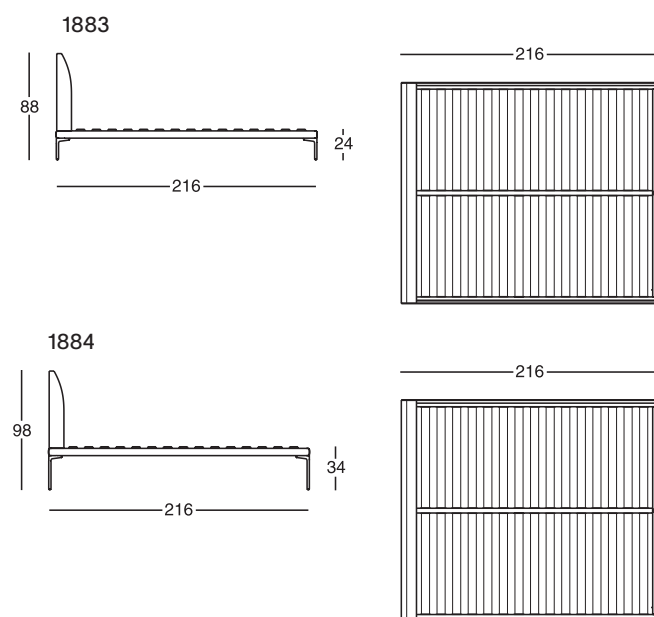

Dimensioni/Sizes/Dimensions/Abmessungen/Medidas

166x216 cm (160x200 cm)*
176x216 cm (170x200 cm)*
186x216 cm (180x200 cm)*
206x216 cm (200x200 cm)*

* Dimensioni del materasso/Mattress sizes/Dimensions du matelas/Abmessungen der Matratze/Medidas del colchón

1883
piedino h. 17,5 cm
foot h. 17,5 cm
pied h. 17,5 cm
Fuß h. 17,5 cm
pie h. 17,5 cm

1884
piedino h. 27,5 cm
foot h. 27,5 cm
pied h. 27,5 cm
Fuß h. 27,5 cm
pie h. 27,5 cm

Piedini/Feet/Pieds/Füße/Patas



Talamo Box ¹⁸⁴⁰



Design

Damian Williamson

2011

Letto con vano contenitore
Struttura rete in acciaio verniciato colore alluminio. Molleggio in doghe di faggio curvato, colore naturale. Imbottitura testiera in poliuretano schiumato autoestingente/fibra poliestere termolegata. Rivestimento sfilabile in stoffa o pelle. Il letto, all'interno della base, è dotato di un vano contenitore, al quale si accede alzando la rete tramite un meccanismo.

Bed with container unit
Aluminium varnished steel springing frame. Suspension in natural bent beech strips. Upholstered headboard in self-extinguishing polyurethane foam/heat-bound polyester fibre. Removable cover in fabric or leather. The bed fitted inside the base, is furnished with a container unit accessed by lifting the springing with a special device.

Lit avec élément de rangement
Sommier en acier verni, couleur aluminium. Suspensions en douves de hêtre courbé, couleur naturelle. Tête de lit rembourré en mousse de polyuréthane autoextinguible/fibre polyester liée à chaud. Revêtement déhoussable en tissu ou en cuir. Le lit, à l'intérieur du cadre, est doté d'un élément de rangement auquel l'on accède en levant le sommier à l'aide d'un mécanisme.

Bett mit Stauraum
Bettkasten aus alufarben lackiertem Stahl. Lattenrost aus gebogenen Buchen-Dauben, naturfarben. Kopfteil mit selbstlöschendem Polyurethanschaum/wärmegebundener Polyesterfaser gepolstert. Abnehmbarer Bezug aus Stoff oder Leder. Das Bett hat im Bettrahmen einen integrierten Stauraum, der über einen Mechanismus zum Anheben der Bettkasten zugänglich wird.

Cama con base contenedora
Estructura somier de acero pintado color aluminio. Suspensión con lamas de haya curvadas, de color natural. Cabezal acolchado de espuma de poliuretano autoextintivo/fibra poliéster termounida. Tapizado desenfundable de tejido o de piel. La cama está provista de una base contenedora a la cual se accede alzando el somier por medio de un mecanismo.

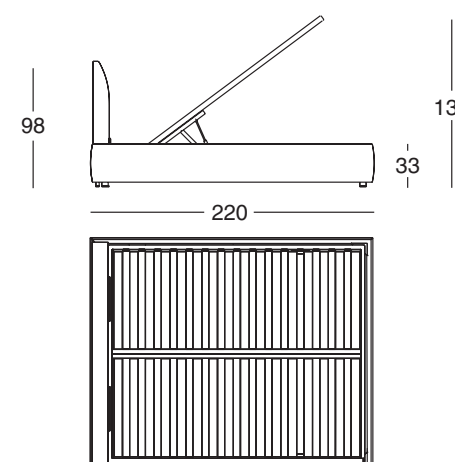

Dimensioni/Sizes/Dimensions/Abmessungen/Medidas

172x220 cm (160x200 cm)*
182x220 cm (170x200 cm)*
192x220 cm (180x200 cm)*

* Dimensioni del materasso/Mattress sizes/ Dimensions du matelas/ Abmessungen der Matratze/Medidas del colchón

Za:Za Bed ¹⁷⁵⁰



Za:Za Bed ¹⁷⁵¹



Design

Zaven

2024

Letto con vano contenitore. Testiera e base in MDF con imbottitura in fibra PET riciclato. Struttura rete in acciaio verniciato colore alluminio. Molleggio in doghe di faggio curvato, verniciato naturale. Rivestimento interno in tessuto di poliestere/cotone. Rivestimento esterno sfilabile in stoffa. Il letto, all'interno della base, è dotato di un vano contenitore, al quale si accede alzando la rete tramite un meccanismo.

Bed with container unit. Headboard and base in MDF with padding in recycled PET fibre. Aluminum varnished steel springing frame. Suspension in natural bent beech strips. Internal upholstery in polyester/cotton fabric. Removable external fabric cover. The bed, fitted inside the base, is equipped with a container unit accessed by lifting the springing with a special device.

Lit avec élément de rangement Tête de lit et base en MDF avec rembourrage en fibre PET recyclée. Sommier en acier verni couleur aluminium. Suspension en douves de hêtre courbé, couleur naturelle. Revêtement intérieur en tissu polyester/coton. Revêtement extérieur déhoussable en tissu. Le lit, à l'intérieur du cadre, est équipé d'un élément de rangement auquel l'on accède en levant le sommier à l'aide d'un mécanisme.

Bett mit Stauraum Kopfteil und Unterteil aus MDF mit Polsterung aus recycelter PET-Faser. Bettkasten aus alufarben lackiertem Stahl. Lattenrost aus gebogenen Buchen-Dauben, naturfarben. Innenbezug aus Polyester/Baumwollgewebe. Abnehmbarer Bezug aus Stoff. Das Bett hat im Bettrahmen einen integrierten Stauraum, der über einen Mechanismus zugänglich wird.

Cama con base contenidora Cabezal y base de MDF acolchados en fibra PET reciclado. Estructura somier de acero pintado color aluminio. Suspensión con lamas de haya curvadas, de color natural. Tapizado interior de tejido de poliéster/algodón. Tapizado exterior desenfundable de tejido. La cama está provista con los soportes angulares regulables en altura en las que se pueden colocar el somier por medio de un mecanismo.

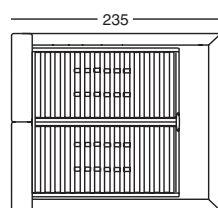
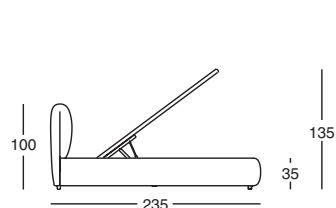

Dimensioni/Sizes/Dimensions/Abmessungen/Medidas

195x235 cm (160x200 cm)*
205x235 cm (170x200 cm)*
215x235 cm (180x200 cm)*

* Dimensioni del materasso/Mattress sizes/ Dimensions du matelas/Abmessungen der Matratze/ Medidas del colchón

Design

Zaven

2024

Letto Testiera e base in MDF con imbottitura in fibra PET riciclato. Rivestimento interno in tessuto di poliestere/cotone. Rivestimento esterno sfilabile in stoffa. Il letto è dotato di angolari regolabili in altezza su cui appoggiano le reti di supporto al materasso, fornite a parte.

Bed Headboard and base in MDF with padding in recycled PET fibre. Internal upholstery in polyester/cotton fabric. Removable external fabric cover. The bed is equipped with height-adjustable corner supports on which the separately supplied springing can be placed.

Lit Tête de lit et base en MDF avec rembourrage en fibre PET recyclée. Revêtement intérieur en tissu polyester/coton. Revêtement extérieur déhoussable en tissu. Le lit est fourni avec des supports angulaires réglables en hauteur qui permettent l'introduction du sommier sur lesquels reposent les sommiers fournis séparément.

Bett Kopfteil und Unterteil aus MDF mit Polsterung aus recycelter PET-Faser. Innenbezug aus Polyester/Baumwollgewebe. Abnehmbarer Bezug aus Stoff. Das Bett ist mit höhenverstellbaren Winkelhalterungen ausgestattet, auf die, die separat gelieferten Bettroste aufgesetzt werden können.

Cama Cabezal y base de MDF acolchados en fibra PET reciclado. Tapizado interior de tejido de poliéster/algodón. Tapizado exterior desenfundable de tejido. La cama está provista con los soportes angulares regulables en altura en las que se pueden colocar el somier suministrado por separado.

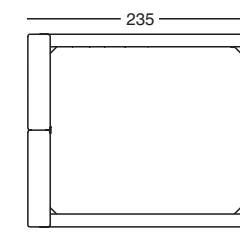
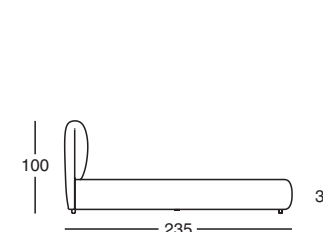

Dimensioni/Sizes/Dimensions/Abmessungen/Medidas

195x235 cm (160x200 cm)*
205x235 cm (170x200 cm)*
215x235 cm (180x200 cm)*

* Dimensioni del materasso/Mattress sizes/ Dimensions du matelas/Abmessungen der Matratze/ Medidas del colchón

Confortevole 1890/1891

Materasso a molle insacchettate con automodellante/Pocket sprung mattress with memory foam/Matelas à ressorts ensachés avec auto-moulant/Selbstmodellierende Matratze mit Taschenfedern/Colchón de muelles ensacados con auto-amoldante

Dimensioni/ Sizes/ Dimensions/ Abmessungen/ Medidas	100x200 cm 140x200 cm 160x200 cm 170x200 cm 180x200 cm 200x200 cm
80x200 cm 85x200 cm 90x200 cm	1890 - h 20 cm 1891 - h 30 cm

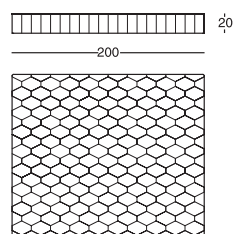

Formaplus 1889

Materasso automodellante/Memory foam mattress/Matelas auto-moulant/Selbstmodellierende Matratze/Colchón auto-amoldante

Dimensioni/Sizes/Dimensions/ Abmessungen/Medidas	80x200 cm 85x200 cm 90x200 cm 100x200 cm 140x200 cm 160x200 cm 170x200 cm 180x200 cm 200x200 cm
---	---

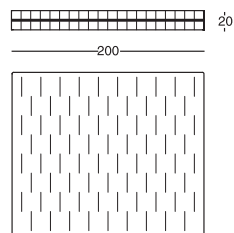

Mollaplus 1887

Materasso a molle insacchettate/Pocket sprung mattress/Matelas à ressorts ensachés/Matratze mit Taschenfedern/Colchón de muelles ensacados

Dimensioni/Sizes/Dimensions/ Abmessungen/Medidas	80x200 cm 85x200 cm 90x200 cm 100x200 cm 140x200 cm 160x200 cm 170x200 cm 180x200 cm 200x200 cm
---	---

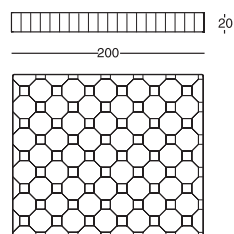

Molleggio 1886

Materasso a molle/Spring mattress/Matelas à ressorts/Matratze mit Stahlfedern/Colchón de muelles

Dimensioni/Sizes/Dimensions/ Abmessungen/Medidas	90x200 cm 140x200 cm 160x200 cm 170x200 cm 180x200 cm 200x200 cm
---	---

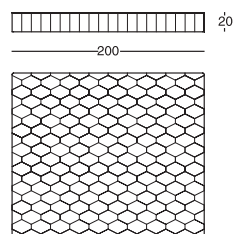

Natura 1893

Materasso in lattice/Latex mattress/Matelas en latex/Latex-Matratze/Colchón de látex

Dimensioni/Sizes/Dimensions/ Abmessungen/Medidas	80x200 cm 85x200 cm 90x200 cm 100x200 cm 140x200 cm 160x200 cm 170x200 cm 180x200 cm 200x200 cm
---	---

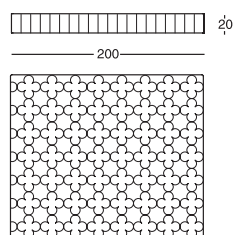

Topper 1898

Materassino aggiuntivo per materassi/Mattress topper/Petit matelas d'appoint pour matelas/Matratzenauflage für normale Matratzen/Colchoncillo adicional para colchones

Dimensioni/Sizes/Dimensions/ Abmessungen/Medidas	80x200 cm 85x200 cm 90x200 cm 100x200 cm 140x200 cm 160x200 cm 170x200 cm 180x200 cm 200x200 cm
---	---

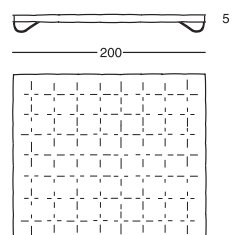

Pisolo 1896

Guanciale in Hollofil/ Hollofil pillow/ Oreiller en Hollofil/ Hollofil Kissen/ Almohada de Hollofil

Guanciale in piuma/ Feather pillow/ Oreiller en plume/ Daunenkissen/ Almohada de piuma

Guanciale automodellante cervicale/Wave-shaped memory foam pillow/Oreiller auto-moulante à deux ondes/Selbstmodellierendes Kissen mit zwei Erhebungen/ Almohada auto-amoldante con doble ola

Guanciale in lattice cervicale/Wave-shaped latex pillow/Oreiller en latex à deux ondes/Kissen aus Latex mit zwei Erhebungen/ Almohada de látex con doble ola

In fibra Hollofil, in piuma d'oca e lana : 50x80 cm.
In lattice: 45x65 cm.
In automodellante: 42x72 cm.



Reti letto 1752/1753/1754

Reti amovibili

Codice 1752 versione fissa, telaio portante in multistrato di faggio, molleggio in doghe di faggio curvato, colore naturale inserite in giunti basculanti di lattice. Codice 1753 versione fissa, telaio portante in multistrato di faggio, molleggio in doghe di faggio curvato con carta protettiva anti-umidità, inserite in giunti realizzati in tecnopolimero, zona lombare modulabile con cursori di rigidità. Codice 1754 versione regolabile, doppio telaio portante in multistrato di faggio, molleggio in doghe di faggio curvato con carta protettiva anti-umidità, inserite in giunti realizzati in tecnopolimero, zona lombare modulabile con cursori di rigidità. L'inclinazione dei gruppi di doghe in corrispondenza delle testiere e delle pediere sono regolabili, indipendentemente, mediante movimento a comando manuale.

Removable slatted bases.
Code 1752: fixed version, supporting frame in beech plywood, natural colour, suspension in natural curved beech slats, inserted in latex tilting joints. Code 1753: fixed version, supporting frame in beech plywood, suspension in curved beech slats with moisture-proof protective paper, inserted in technopolymer joints, adjustable lumbar zone with rigidity sliders. Code 1754 adjustable version: double supporting frame in beech plywood, suspension in curved beech slats with moisture-proof protective paper, inserted in technopolymer joints, adjustable lumbar zone with rigidity sliders. The inclination of the slats in correspondence of the headboard and footboard are adjustable, independently, by means of a manually controlled movement.

Sommieri amovibili.

Code 1752: version fixe, cadre de support en contreplaqué de hêtre, suspension en lattes de hêtre courbé, couleur naturelle, insérées dans des joints basculants en latex. Code 1753: version fixe, cadre de support en contreplaqué de hêtre, suspension en lattes de hêtre courbé, avec papier de protection anti-humidité, insérées dans des joints en technopolymère, zone lombaire réglable avec des curseurs de rigidité. Code 1754 version réglable: double cadre de support en contreplaqué de hêtre, suspension en lattes de hêtre courbé avec papier de protection anti-humidité, insérées dans des joints en technopolymère, zone lombaire réglable avec des curseurs de rigidité. L'inclinaison des lattes au niveau de la tête et du pied de lit peut être réglée indépendamment au moyen d'un mouvement à commande manuelle.

Abnehmbare Lattenroste.

Kode-Nr. 1752: feste Version, Tragrahmen aus Buchenspertholz, Federung aus gebogenen Buchenholzlaten, naturfarben, in Latex-Gelenke eingefügt. Kode-Nr. 1753: feste Version, Tragrahmen aus Buchenspertholz, Federung aus gebogenen Buchenholzlaten mit Feuchtigkeitsschutzpapier, in Technopolymer-Gelenke eingefügt. Lendenwirbelbereich modulierbar mit Steifigkeitsschiebern. Kode-Nr. 1754: verstellbare Version, doppelter Tragrahmen aus Buchenspertholz, Federung aus gebogenen Buchenholzlaten mit Feuchtigkeitsschutzpapier, in Technopolymer-Gelenke eingefügt. Lendenwirbelbereich modulierbar mit Steifigkeitsschiebern. Die Neigung der Lattengruppen beim Kopf- und Fußteilen kann unabhängig voneinander durch eine manuelle gesteuerte Bewegung eingestellt werden.

Somieres desmontables.

Código 1752 versión fija, marco portante de madera contrachapada de haya, somier con lamas de haya curvadas, color natural, insertadas en juntas basculantes de látex. Código 1753 versión fija, marco portante de madera contrachapada de haya, somier con lamas de haya curvadas con papel protector de la humedad, insertadas en juntas de tecnopolímero, zona lumbar regulable con deslizadores de rigidez. Código 1754 versión regulable, doble marco portante de madera contrachapada de haya, somier con lamas de haya curvadas con papel protector de la humedad, insertadas en juntas de tecnopolímero, zona lumbar regulable con deslizadores de rigidez. La inclinación de los grupos de lamas en los cabezal y pieceros puede ajustarse independientemente mediante un movimiento controlado manualmente.

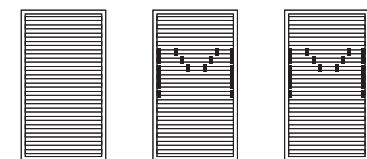

80x200 cm
85x200 cm
90x200 cm

Lenzuola 1799

Lenzuola

La parure estiva include un lenzuolo sotto, un lenzuolo sopra e due federe per guanciali. La parure invernale include un lenzuolo sotto, un copripiumino e due federe per guanciali. Le parure sono realizzate in Percalle di cotone con cuciture tono su tono nei colori della cartella.

Sheets

The summer set includes a fitted sheet, a top sheet and two pillowcases. The winter set includes a fitted sheet, a duvet cover and two pillowcases. The sets are made of percale cotton with tone-on-tone stitching in the colours of the sample card.

Drap

La parure d'été comprend un drap-housse, un drap de dessus et deux taies d'oreiller. La parure d'hiver comprend un drap-housse, une housse de couette et deux taies d'oreiller. Les parures sont en percale de coton avec des coutures ton sur ton dans les couleurs de la fiche.

Laken

Das Sommer-Set besteht aus einem Spannbettlaken, einem Oberlaken und zwei Kissenbezüge. Das Winter-Set besteht aus einem Spannbettlaken, einem Bettbezug und zwei Kissenbezüge. Die Sets sind aus Baumwolle Perkal mit Ton-in-Ton-Nähten, in den Farben der Musterkarte.

Sábanas

El juego de verano incluye una sábana bajera, una sábana encimera y las dos fundas de almohada. El juego de invierno incluye una sábana bajera, una funda nórdica y las dos fundas de almohada. Los juegos son de percal de algodón con pespuntos tono sobre tono en los colores del muestrario.

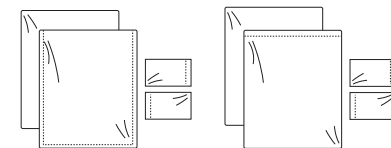

170x200 cm
190x200 cm
200x200 cm



Furnishing accessories

Complementi
d'arredo
Compléments
d'ameublement
Wohnaccessoires
Complementos
de decoración

204–233

Albero ⁴⁰⁰



Design

Achille Castiglioni

1983

Portavasi con piani rotanti
Struttura in acciaio verniciato nei colori talco, amaranto, verde prato o nero. Piattelli portavasi in poliammide, colore nero. Piedini in polipropilene colore nero.

Rotating flowerpot stand
Painted steel frame in the shades talc, amaranth, grass green or black. Pot-holder dishes in black polyamide. Black polypropylene feet.

Jardinière à plateau tournant
Structure en acier verni dans les couleurs talc, rouge amarante, vert pré ou noir. Petits plats en polyamide, couleur noire. Pieds en polypropylène noir.

Blumenständer mit drehbaren Ablagen
Gestell aus lackiertem Stahl, in den Farben Talkum, amarantröt, grasgrün oder schwarz. Polyamid-Untersetzer, schwarzfarben. Füße aus schwarzem Polypropylen.

Macetas con patas giratorias
Estructura en acero pintado en los colores talco, granate, verde prado o negro. Platinos porta-macetas en poliamida color negro. Patas en polipropileno negro.

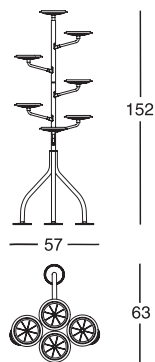

Struttura/Frame/Structure/ Gestell/Estructura



Allunaggio ²³⁰



Design

Achille e Pier Giacomo Castiglioni 1965

IN/OUT

Sedile per esterni
Gambe in acciaio, sedile in lega di alluminio, verniciati colore verde prato. Piedini in polietilene, colore naturale.

Outdoor stool
Steel legs, aluminium alloy seat painted grass green. Natural polyethylene feet.

Siège pour extérieurs
Pieds en acier, siège en alliage d'aluminium, vernis vert pré. Pieds en polyéthylène, couleur naturelle.

Stuhl fürs Freie
Beine aus Stahl, Sitz aus Aluminiumlegierung, grasgrün lackiert. Fußenden aus naturfarbenem Polyäthylen.

Taburete para exteriores
Patas de acero, asiento de aleación de aluminio, pintados de color verde prado. Pies de polietileno de color natural.

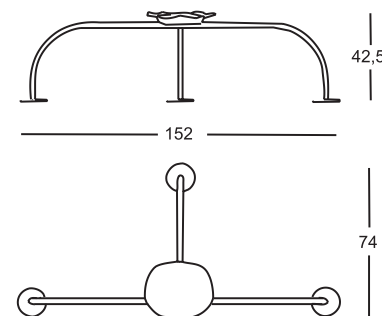

Ara Fenice ⁹⁵⁶⁰



Design

Piero Bottoni

1951

Alzata

Alzata realizzata in cemento e inerti, colore grigio.

Centerpiece

Centerpiece made of cement and aggregates, colour grey.

Centre table

Centre table en ciment et granulats, de couleur grise.

Tafelaufsatz

Tafelaufsatz aus Zement und Zuschlagstoffen, graufarben.

Centro de mesa

Centro de mesa en cemento y agregados, color gris.

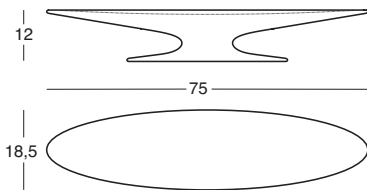

Aster ³⁰³



Design

Alessandro Dubini

2010

Appendiabiti

Struttura in acciaio verniciato, colore talco, amaranto o nero.

Clothes stand

Steel frame painted talc, amaranth or black.

Portemanteaux

Structure en acier vernie talc, rouge amarante ou noire.

Kleiderständer

Gestell aus Talkum, amarantrot oder schwarz lackiertem Stahl.

Colgador

Estructura de acero barnizado de color talco, granate o negro.

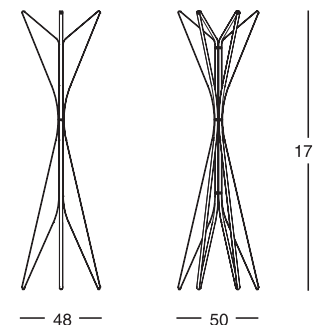

Struttura/Frame/Structure/ Gestell/ Estructura



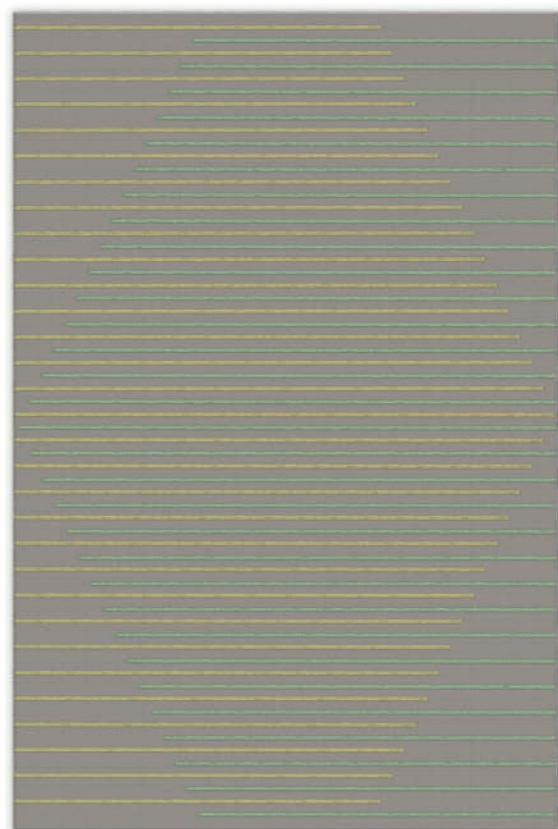

Designi

Pierre Charpin

2026

Tappeto rettangolare
Tappeto annodato a mano realizzato in lana, disponibile nelle versioni con base cioccolato e righe color cappuccino e azzurro e con base grigia e righe color verde e lime.

Rectangular carpet
Hand-knotted wool carpet, available in two versions: one with chocolate base and cappuccino and light blue stripes, and one with grey base and green and lime stripes.

Rechteckiger Teppich
Handgeknüpfter Teppich aus Wolle, erhältlich in den Ausführungen mit schokoladenbraunem Grund und Streifen in Cappuccino und Hellblau und mit grauem Grund und Streifen in Grün und Limettengrün.

Tapis rectangulaire
Tapis noué à la main en laine, disponible dans deux versions : avec un fond chocolat et des rayures couleur cappuccino et bleu clair, et avec un fond gris et des rayures couleur vert et citron vert.

Alfombra rectangular
Alfombra tejida a mano de lana, disponible en dos versiones: con fondo color chocolate y rayas en color capuchino y azul claro, y con fondo gris y rayas en color verde y lima.

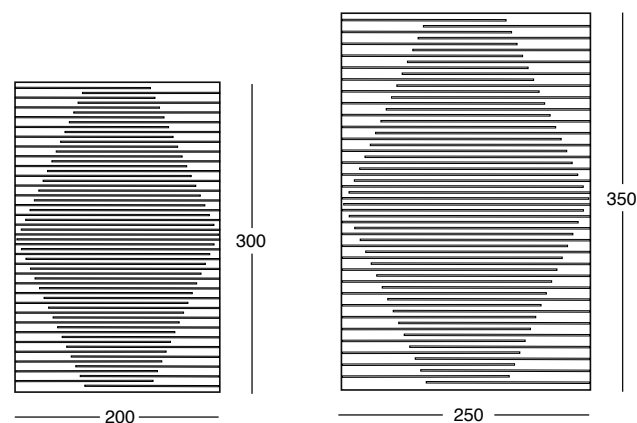

Design

G. Levi Montalcini, G. Pagano Pogatschnig

1932

Portaoggetti
Struttura in tubo di acciaio cromato. Pianetti in laminato plastico stratificato, colore bianco/nero, reversibile.

Objects stand
Chromium-plated, tubular steel frame. Shelves in reversible black/white plastic laminate.

Porte-objets
Structure en tube d'acier chromé. Plateaux en laminé plastique stratifié, couleur blanche/noire, réversible.

Ständer für Gegenstände
Gestell aus verchromtem Stahlrohr. Platten aus Schichtpress-Stoff Laminat, weiß/schwarz, umkehrbar.

Porta objetos
Estructura tubular de acero cromado. Estantes de laminado plástico estratificado, color blanco/negro, reversible.

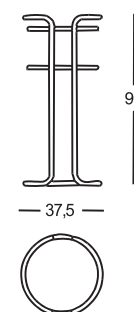

Cuculia 9400



Design

Alessandro Mendini

1985

Ciotola

Struttura in poliuretano rigido, laccatura lucida brillante bicolore. Ciotola diametro 25 cm: interno giallo, esterno lilla. Ciotola diametro 51 cm: interno rosso corallo/esterno verde oppure interno amaranto/esterno caramello.

Bowl

Hard polyurethane frame, two-tone glossy lacquer finish. Bowl diameter 25 cm: yellow inside, lilac outside. Bowl diameter 51 cm: coral red inside/green outside or amaranth inside/caramel outside.

Bol

Structure en polyuréthane rigide, laqué poli brillant bicolore, Diamètre du bol 25 cm: intérieur jaune, extérieur lilas. Diamètre du bol 51 cm: intérieur rouge corail/ extérieur vert ou intérieur amarante/extérieur caramel.

Schale

Form aus hartem Polyurethan, zweifarbig glänzend lackiert. Durchmesser der Schale 25 cm: innen gelb/außen fliederfarben. Durchmesser der Schale 51 cm: innen korallenrot/ außen grün oder innen Amarantrat/ außen karamell.

Tazón

Estructura de poliuretano rigido, lacado brillante bicolore. Tazón de 25 cm de diámetro: interior amarillo/ exterior lila. Tazón de 51 cm de diámetro: interior rojo coral/ exterior verde o interior granate/ exterior caramelo.

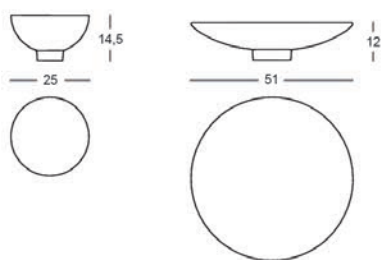

Dealbata 9550/9551/9552



Design

Alessandro Mendini

1986

Vasi

Vasi in argilla smaltata bianca o arancione lucido. Interventi di decorazione ornamentale applicati a mano.

Vases

Vases in white or orange glazed clay. Hand-applied ornamental decoration.

Vases

Vases en terre cuite émaillée blanche ou orange brillante. Décoration ornamentale appliquée à la main.

Vasen

Vasen aus weiß oder Orange glasiertem Ton. Handgearbeitete Zierdekoration.

Jarrónes

Jarrónes en arcilla esmaltada blanco o naranja brillante. Intervenciones de decoración ornamental aplicadas a mano.

9550

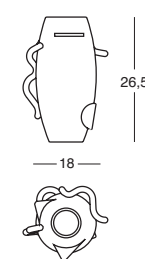

9551

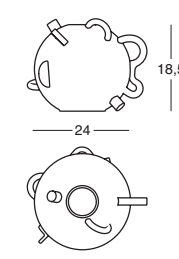

9552

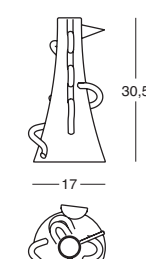



Design

Calvi Brambilla

2025

Tappeto

Tappeto annodato a mano composizione fibrosa 90% lana, 10% cotone. Spessore 15 mm, peso 3,5 Kg/mq. Colori cera, canapa, alga, amaranto e blu.

Carpet

Hand-knotted carpet, fibrous composition 90% wool, 10% cotton. Thickness 15 mm, weight 3.5 Kg/sqm. Colours: wax, hemp, algae, amaranth and blue.

Tapis

Tapis noué à la main composition fibreuse 90% laine, 10% coton. Epaisseur 15 mm, poids 3,5 Kg/m². Coloris: cire, chanvre, algues, amarante et bleu.

Teppich

Handgeknüpfter Teppich mit Faserzusammensetzung 90% Wolle, 10% Baumwolle. Stärke 15 mm, Gewicht 3,5 kg/qm. Farben: Wachs, Hanf, Algen, Amarantröt und Blau.

Alfombra

Alfombra anudada a mano composición fibrosa 90% lana, 10% algodón. Espesor 15 mm, peso 3,5 Kg/m². Colores: cera, cáñamo, alga, granate y azul.

170

171

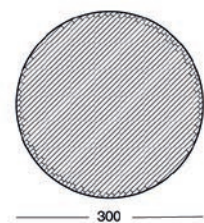

200x300 cm / 350x250 cm (mod. 170)
Ø 300 cm (mod. 171)



Design

Calvi Brambilla

2026

Cuscino decorativo

Imbottitura in fibra soffiata di PET riciclato rivestita con tela in PET riciclato. Rivestimento in tessuto jacquard nei colori amaranto e canapa.

Decorative cushion

Padding with recycled PET blown fibre, covered with recycled PET canvas. Upholstery in jacquard-woven fabric in amaranth and hemp colours.

Coussin décoratif

Rembourrage en fibre de PET recyclé soufflée, recouvert d'une toile en PET recyclé. Revêtement en tissu jacquard dans les couleurs rouge amarante et chanvre.

Dekoratives Kissen

Polsterung aus geblasener PET-Recyclingfaser, die mit recyceltem PET-Gewebe ummantelt ist. Bezug aus Jacquard-Stoff in den Farben Amarantröt und Hanf.

Cojín decorativo

Acolchado de fibra de PET reciclada soplada, revestida con lona/tela de PET reciclada. Tapizado en tejido jacquard en tonos granate y cáñamo.

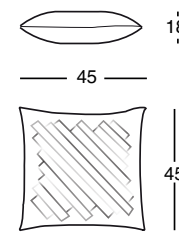

Folia ¹⁰⁰



Design

Giuseppe Terragni

1934

Poltroncina

Sedile e schienale colore nero. Balestre di sostegno schienale in acciaio inox 18/8.

Chair

Black seat and back. 18/8 stainless steel backrest support spring.

Petit fauteuil

Siège et dossier couleur noire. Ressort de soutien en acier inox 18/8.

Stuhl

Sitzfläche und Rückenlehne schwarz. Federbogen der Rückenlehne aus Inox- Stahl 18/8.

Butaquita

Asiento y respaldo de color negro. Elementos de soporte respaldo de acero inox 18/8.

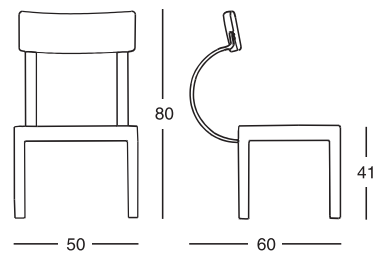

Giotto ²⁵⁰



Design

De Pas, D'Urbino, Lomazzi

1975

Sgabello

Struttura in faggio, colore naturale, con crociera rossa. Sedile girevole e regolabile in altezza.

Stool

Natural varnished beech frame with red bracket. Vertically adjustable revolving seat.

Tabouret

Structure en hêtre naturel avec croisillon rouge. Assise tournante et réglable en hauteur.

Hocker

Struktur aus Buche, naturfarben, mit rotem Kreuz. Drehbarer Sitz, höhenverstellbar.

Taburete

Estructura de haya natural con cruceta en rojo. Asiento giratorio y regulable en altura.

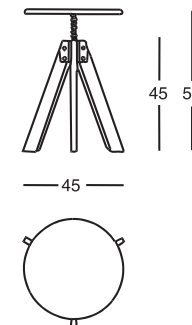



Design

Achille Castiglioni

1989

Libreria a ripiani rotanti
Piani in medium density fiberboard, verniciatura gofrata antigraffio nei colori talco, canapa, amaranto, espresso o nero. Snodo in acciaio verniciato nero nelle versioni canapa, amaranto, espresso o nera, oppure talco nella versione talco. Il mobile è disponibile nella versione a cinque o a sette ripiani.

Rotating shelf bookcase
Uprights and shelves in medium density fiberboard, finished with scratch-resistant embossing in the shades talc, hemp, amaranto, espresso or black. Steel articulated joint in the shade black for the models hemp, amaranto, espresso, black or in the shade talc for the talc model. The shelf unit is available with either five or seven shelves.

Bibliothèque avec étagères pivotantes
Éléments en medium density fiberboard avec vernissage gaufré anti-rayures dans couleurs talc, chanvre, rouge amarante, espresso ou noire. Articulation en acier verni noir dans les versions chanvre, rouge amarante, espresso, noire, ou verni talc pour la version talc. Le meuble est disponible dans la version avec cinq ou sept étagères.

Bücherregal mit Drehregalen
Platten aus Medium Density Fiberboard, kratzfest gaufriert lackiert in den Farben Talkum, Hanf, Amarantröt, Espresso oder schwarz. Verbindungsstück aus schwarz- lackiertem Stahl für die Modelle in den Farben Hanf, Amarantröt, Espresso, schwarz, oder Talkum-lackiert für die Talkum-Version. Das Drehregal ist in zwei Versionen lieferbar, bzw. mit fünf oder sieben Platten.

Biblioteca con estantes giratorios
Estantes de MDF lacado en relieve anti-rasguño en los colores talco, cañamo, granate, espresso o negro. Articulación de acero pintado negro por las versiones en cañamo, granate, espresso, negro o talco por la versión en talco. El mueble está disponible con cinco o siete estantes.

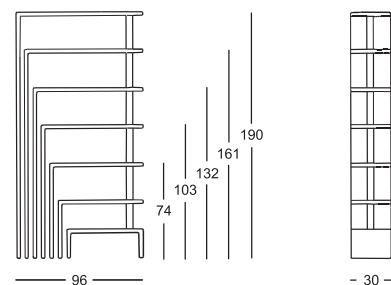

Design

Achille e Pier Giacomo Castiglioni 1957

Sgabello
Gambo in acciaio cromato. Sedile verniciato nei colori: arancio, rosso, giallo, bianco o nero. Base in faggio evaporato, colore naturale.

Stool
Chromium-plated steel stem. Seat lacquered in the colours: orange, red, yellow, white or black. Footrest in steam-treated beech, natural colour.

Tabouret
Pied en acier chromé. Siège verni dans les couleurs: orange, rouge, jaune, blanc ou noir. Base en hêtre évaporé, couleur naturelle.

Hocker
Stützstange aus verchromtem Stahl. Sitz lackiert orange, rot, gelb, weiß oder schwarz. Fuß aus gedampfter Buche, naturfarben.

Taburete
Pata de acero cromado. Asiento pintado en los colores: rojo, naranja, amarillo, blanco o negro. Base de haya vaporizada, color natural.

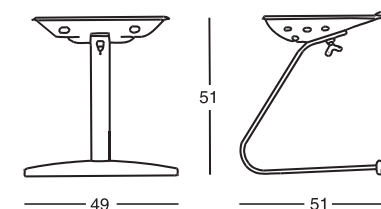

Museo ³¹⁰



Design

Enzo Mari

1991

Appendiabiti a muro
Elemento singolo in acciaio verniciato antigraffio, colore talco o nero.

Coat hanger
Single steel element painted talc or black with scratch resistant finish.

Porte-manteaux a mur
Élément single en acier verni anti-rayures, couleur talc ou noire.

Wandgarderobe
Einzelelement aus Stahl mit Anti-Kratzer-Lackierung, Farbe Talkum oder schwarz.

Perchero de pared
Elemento colgador de acero, lacado con relieve antirasguño de color talco o negro.

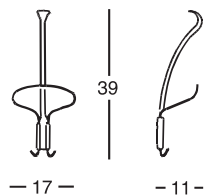

Primate ²⁴⁰



Design

Achille Castiglioni

1970

Sedile inginocchiatoio
Struttura in poliuretano rigido. Basamento in polistirolo, colore nero. Imbottitura in poliuretano flessibile. Gambo in acciaio inox 18/8. Rivestimento in Ecofire o pelle 95.

Kneeling-stool
Stiff polyurethane frame. Base in black painted polystyrene. Flexible polyurethane upholstery. 18/8 stainless steel leg. Cover in Ecofire or leather 95.

Siège-agenouilloir
Structure en polyuréthane rigide. Embase en polystyrène, couleur noire. Rembourrage en polyuréthane flexible. Tige en acier inox 18/8. Revêtement en Ecofire ou cuir 95.

Kniesitz
Gestell aus steifem Polyurethan. Basis aus schwarzem Polystyrol. Polsterung aus flexiblem Polyurethan. Stützstange aus Inox-Stahl 18/8. Bezug aus Ecofire oder Leder 95.

Asiento ergonómico
Estructura de poliuretano rígido. Base de poliestirol, de color negro. Acolchado de poliuretano flexible. Elemento de soporte asiento de acero inox 18/8. Tapizado en Ecofire o piel 95.

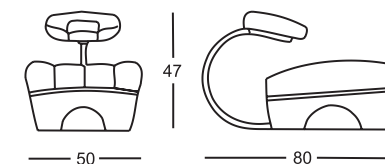

Quaderna Carpet ¹⁵⁰

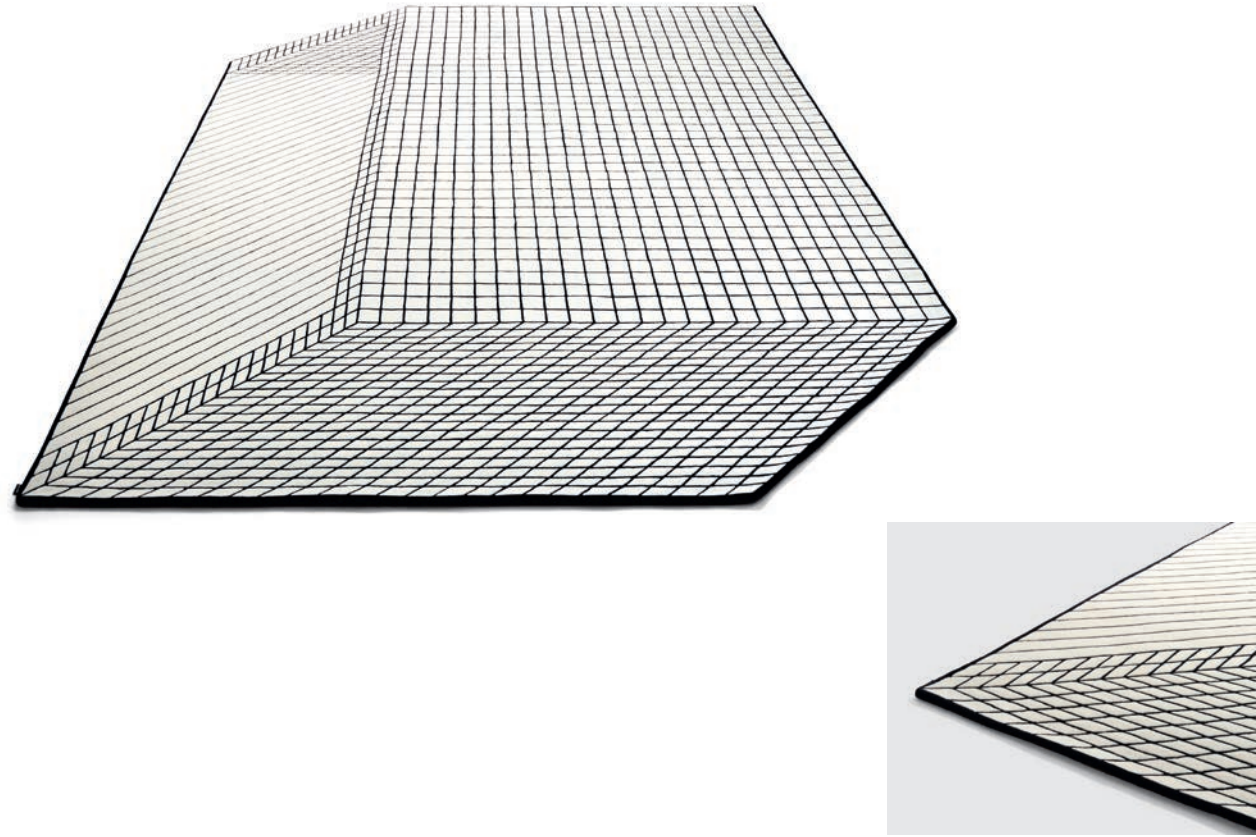

Design **Superstudio / Cristiano Toraldo di Francia** 1969-1972

Tappeto
Tappeto tuftato a mano con vello uniforme su tutta la superficie realizzato in 100% lana neozelandese. Supporto inferiore in tela 100% cotone fissata con colla in lattice 100% naturale. Bordatura perimetrale eseguita a mano con filo di lana a rifinire i sei lati. Disponibile nella dimensione 200x300 e 250x350 cm in un unico colore: fondo bianco e linee grigie e nere in linea con il disegno originale.

Carpet
Hand-tufted carpet with uniform fleece over the entire surface made of 100% New Zealand wool. Perimeter edging finished by hand with wool thread on all six sides. Available in sizes 200x300 cm and 250x350 cm in a single colour scheme: white background and gray and black lines compliant with the original design.

Tapis
Tapis tufté à la main avec toison uniforme sur toute la surface en laine 100% néo-zélandaise. Ordure périmétrique réalisée à la main avec du fil de laine pour finir les six côtés. Disponible en tailles 200x300 et 250x350 cm en une seule couleur: fond blanc et lignes grises et noires en ligne avec le design original.

Teppich
Handgetufteter Teppich mit einheitlichem Vlies über die gesamte Fläche aus 100% neuseeländischer Wolle. Umfangseinfassung von Hand mit Wollfaden, um die sechs Seiten zu beenden. Erhältlich in den Größen 200x300 und 250x350 cm in einer einzigen Farbe: weißer Hintergrund und graue und schwarze Linien im Einklang mit dem ursprünglichen Design.

Alfombra
Alfombra con copetes a mano con vellón uniforme sobre toda la superficie hecha de lana 100% neozelandesa. Soporte inferior en lona 100% algodón fijada con pegamento de látex 100% natural. Borde perimetral realizado a mano con hilo de lana para terminar los seis lados. Disponible en tamaños 200x300 y 250x350 cm en un solo color: fondo blanco y líneas grises y negras en línea con el diseño original.

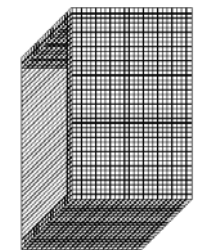

200 x 300 cm
250 x 350 cm

Sciangai ³⁰⁰



Design **De Pas, D'Urbino, Lomazzi** 1973

Appiendibiti chiudibile.
Struttura in legno massello di frassino tinto rovere o tinto grigio, o laccato porto aperto nei colori talco, amaranto e nero.

Folding and adjustable clothes-stand.
Frame made of solid ash wood, stained oak or grey, or open-pore lacquered in talc, amaranth and black.

Portemanteaux pliant et réglable.
Structure en bois massif de frêne teinté rovere ou gris, ou laqué à pores ouvert dans les couleurs talc, rouge amarante et noir.

Zusammenfaltbarer und verstellbarer Kleiderständer.
Gestell aus massiver Esche, gebeizt in Eiche oder grau, oder offenporig lackiert in den Farben Talkum, amaranthrot und schwarz.

Perchero plegable y arreglable.
Estructura de madera maciza de fresno teñida en color roble o gris, o lacada con poro abierto en los colores talco, granate y negro.

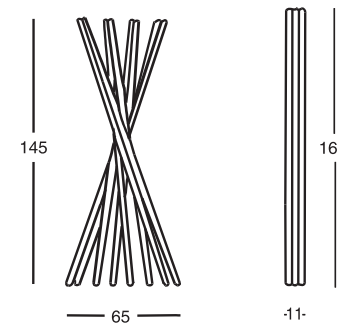

Struttura/Frame/Structure/ Gestell/Estructura

Frassino tinto nero/Black varnished ash/ Frêne teinté noir/ Schwarz-gebeizte Esche/Fresno teñido negro	Frassino tinto grigio/Grey varnished ash/ Frêne teinté gris/ Grau-gebeizte Esche/Fresno teñido gris	Frassino tinto talco/Talc varnished ash/ Frêne teinté talc/ Talkum-gebeizte Esche/Fresno teñido talco	Frassino tinto rovere/Oak varnished ash/ Frêne teinté rovere/Eiche gebeizte Esche/Fresno teñido roble	Frassino tinto amaranto/Amaranth varnished ash/ Frêne teinté rouge amarante/ Amaranthrot-gebeizte Esche/Fresno teñido granate

Sciangai 50 ³⁰¹

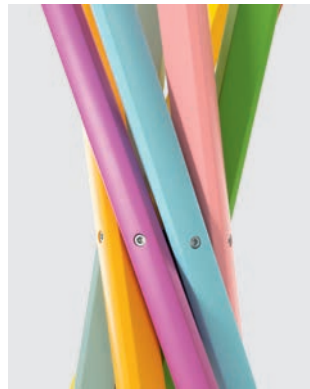

Design

De Pas, D'Urbino, Lomazzi

1973-2023

Appendiabiti chiudibile e regolabile
Struttura in faggio laccata multicolore. Edizione numerata.

Folding and adjustable clothes-stand
Multicoloured lacquered beech frame. Numbered edition.

Portemanteaux pliant et réglable
Structure en hêtre laqué multi-couleur. Édition numérotée.

Zusammenfaltbarer und verstellbarer Kleiderständer
Gestell aus mehrfarbig lackierter Buche. Nummerierte Auflage.

Perchero plegable y arreglable
Estructura de haya lacada multicolor. Edición numerada.

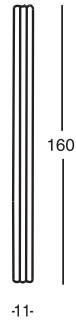
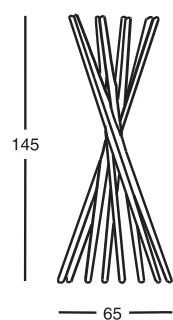

Sella ²⁰⁰



Design

Achille e Pier Giacomo Castiglioni 1957

Sedile
Sella di bicicletta da corsa, colore nero, asta in acciaio verniciato, colore rosa. Basamento in fusione di ghisa.

Seat
Black saddle of racing bicycle, pink lacquered steel column. Cast-iron base.

Siège
Selle de bicyclette de course couleur noire. Tige en acier verni couleur rose. Base en fonte.

Sitz
Rennradsattel Farbe schwarz. Stützstange aus lackiertem Stahl, rosa. Fuß aus Gusseisen.

Taburete
Sillín de bicicleta de carrera de color negro, vástago de acero pintado de rosa. Base en hierro fundido.

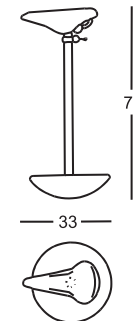

Servento ⁵²⁷



Design **Achille Castiglioni** della serie Servi di Achille & Pier Giacomo Castiglioni **1986**

Paravento

Base in polipropilene verniciato talco, amaranto o nero. Asta di sostegno in acciaio verniciato, colore talco, amaranto o nero. Telo in panno di lana, misure cm 66 x 150, nei colori: grigio chiaro, grigio medio, grigio scuro, rosso, giallo, carta da zucchero, mattone, verde chiaro, verde scuro o viola.

Screen

Base in talc, amaranth or black painted polypropylene. Steel support rod, painted in talc, amaranth or black. Wool canvas screen, sizes cm 66 x 150, in the shades: light grey, medium grey, dark grey, red, yellow, powder blue, brick, light green, dark green or purple.

Paravent

Base en polypropylène verni talc, rouge amarante ou noir. Tige de soutien en acier verni talc, rouge amarante ou noir. Toile en tissu de laine, mesure 66 x 150 cm, dans les couleurs : gris clair, gris moyen, gris foncé, rouge, jaune, bleu poudre, brique, vert clair, vert foncé ou violet.

Paravent

Fuß aus Talkum, amaranthrot oder schwarz lackiertem Polypropylen. Stange aus lackiertem Stahl, in den Farben Talkum, amaranthrot oder schwarz. Leinwand aus Wolle, Maße 66 x 150 cm, in den Farben: hellgrau, mittelgrau, dunkelgrau, rot, gelb, taubenblau, Backstein, hellgrün, dunkelgrün oder Veilchen.

Separador de ambiente

Base de polipropileno pintado talco, granate o negro. Asta de soporte de acero pintado talco, granate o negro. Panel en tejido de lana, medida 66 x 150 cm, en los colores: gris claro, gris medio, gris obscuro, rojo, amarillo, azul polvo, ladrillo, verde claro, verde obscuro o púrpura.

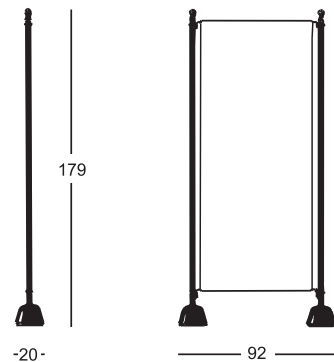

Base/Base/Base/Fuß/Base



Vello

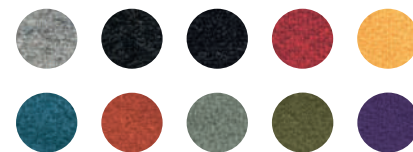

Servonotte ³⁵⁰ Servietto ³⁵⁵

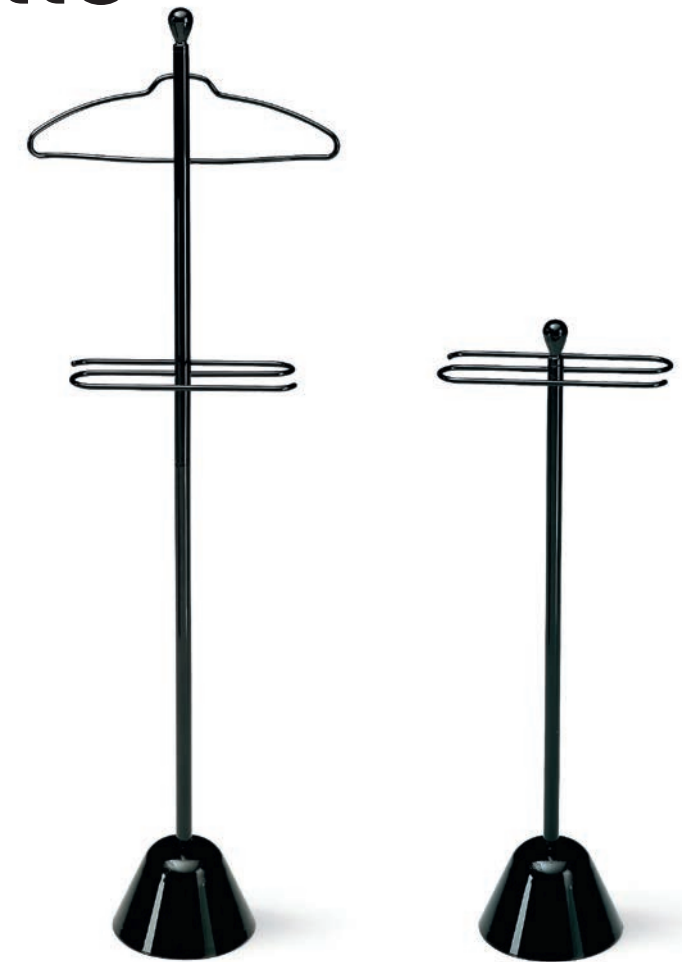

Design **Achille Castiglioni** della serie Servi di Achille & Pier Giacomo Castiglioni **1986**

Portabito/Portasciugamani

Base in polipropilene e struttura verniciate in acciaio, colore talco o nero.

Clothes-stand/Towel-rack

Polypropylene base and steel frame, painted in the colours: talc or black.

Valet de chambre/ porte-serviettes

Base en polypropylène et structure en acier verni, couleur talc ou noire.

Stummer Diener/ Handtuchträger

Fuß aus Polypropylen und Gestell aus lackiertem Stahl, Talkum oder schwarz.

Galán de noche/ porta toallas

Base de polipropileno y estructura de acero pintado en los colores: talco o negro.

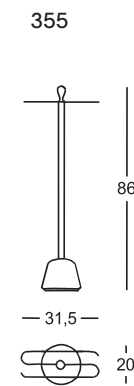
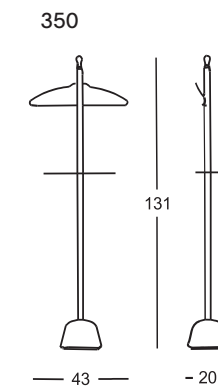

Servobandiera ⁵¹⁵



Design **Achille Castiglioni** della serie Servi di Achille & Pier Giacomo Castiglioni **1986** IN/OUT

Portabandiera

Base in polipropilene verniciato nero. Asta di sostegno in acciaio verniciato, colore nero per esterni. Bandiera in stamigna di lana. Colori, simboli e misure da capitolato. Misura del drappo cm 100 x 150. La bandiera svizzera misura cm 100 x 100. I simboli delle bandiere statunitense e Consiglio d'Europa sono ricamati. Disponibile anche la sola base e asta senza drappo.

Flag-holder

Base in black painted polypropylene. Steel support rod, in the shade black for outdoor. Bunting flag. Regulation colours, symbols and sizes. Flag size cm 100 x 150, Swiss flag cm 100 x 100. On the USA and Council of Europe flags, the symbols are embroidered. Base and support rod, without cloth, are available separately.

Porte-étendard

Base en polypropylène verni noir. Tige de soutien en acier verni couleur noire pour extérieurs. Drapeau en étamine de laine. Couleurs, symboles et mesures suivant cahier de charges. Dimensions du drapeau cm 100 x 150. Le drapeau suisse mesure cm 100 x 100. Les symboles des drapeaux américain et du Conseil d'Europe sont brodés. Nous pouvons fournir la base et la tige de soutien, sans le drapeau.

Fahnenständer

Fuß aus Polypropylen, schwarz lackiert. Stange aus Stahl, schwarz lackiert fürs Freie. Fahne aus Wollelamin. Genormte Farben, Symbole und Maße. Maße 100 x 150 cm. Maße der Schweizer Fahne 100 x 100 cm. Die Symbole Europarats und der USA sind aufgestickt. Fuß und Stange auch ohne Fahne lieferbar.

Portabandera

Base de polipropileno pintado negro. Asta de acero pintado de negro para exteriores. Bandera de lana. Colores, símbolos y medidas según las normas. Medidas de la bandera 100 x 150 cm. La bandera suiza mide 100 x 100 cm. Los símbolos de las banderas estadounidense y del Consejo de Europa están bordados. También suministramos solamente la base y el asta, sin bandera.

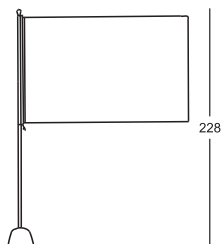

Servofumo ³⁷⁰ Servopluvio ³⁸⁰



Design **Achille e Pier Giacomo Castiglioni** **1961** IN/OUT

Portacenere/portaombrelli

Base in polipropilene, vaschetta in alluminio e struttura di sostegno in acciaio verniciato, colore nero per esterni.

Ashtray/umbrella stand

Base in polypropylene, container in aluminium and steel support frame, black painted for outdoor.

Cendrier/porte-parapluies

Base en polypropylène, bassin en aluminium et structure de soutien en acier verni couleur noire pour extérieurs.

Standascher/Regenschirmständer

Fuß aus Polypropylen, Behälter aus Aluminium und tragendes Gestell aus lackiertem Stahl, schwarzfarben fürs Freie.

Cenicero/paragüero

Base de polipropileno, cubeta de aluminio y estructura de acero pintado, color negro para exteriores.

370/B

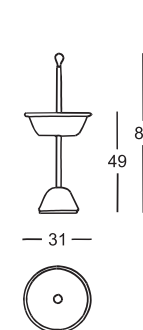

370/A

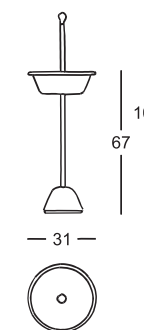

380

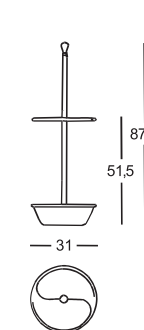

Servomanto 305



Design

Achille Castiglioni della serie Servi di Achille & Pier Giacomo Castiglioni **1985**

Appendiabiti
Base in polipropilene verniciato talco o nero. Asta di sostegno e bracci appendiabiti in acciaio verniciato, colore talco o nero.

Clothes stand
Base in talc or black painted polypropylene. Support rod and arms in talc or black painted steel.

Portemanteaux
Base en polypropylène verni talc ou noir. Tige de soutien et bras en acier verni talc ou noir.

Kleiderständer
Fuß aus Polypropylen, Talkum oder schwarz lackiert. Stützsäule und Arme aus Talkum- oder schwarz lackiertem Stahl.

Perchero
Base de polipropileno pintado talco o negro. Estructura de acero pintado, color talco o negro.

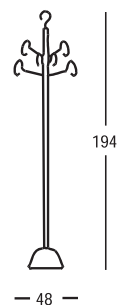

Servostop 525



Design

Achille Castiglioni della serie Servi di Achille & Pier Giacomo Castiglioni **1984**

Transenna
Base in polipropilene verniciato nero. Asta di sostegno con gancio in acciaio verniciato, colore nero. Catena in acciaio verniciato rosso.

Partition system
Base in black painted polypropylene. Black painted steel support rod with hook. Red painted steel chain.

Transenne
Base en polypropylène verni noir. Tige de soutien avec crochet en acier verni noir. Chaîne en acier verni rouge.

Absperrsystem
Fuß aus Polypropylen, schwarz lackiert. Stange mit Haken aus schwarz lackiertem Stahl. Kette aus rot lackiertem Stahl.

Catenaria
Base de polipropileno pintado negro. Asta de soporte con gancho de acero pintado de negro. Cadena de acero barnizado rojo.

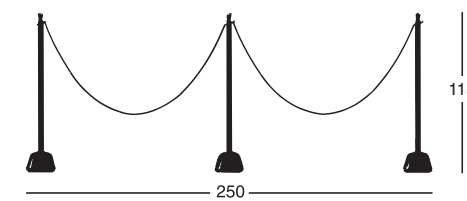

Thar 160/161/162



Tappeto
Tappeto annodato a mano realizzato in 100% lana neozelandese. Bordatura perimetrale, eseguita a mano, con filo di lana. Lo spessore complessivo del tappeto è di circa 22 mm ed il peso è di 3,8 Kg/mq. Colori arancione, canapa o espresso.

Carpet
Hand-knotted carpet made of 100% New Zealand wool. Hand-knotted perimeter edging with wool yarn. The overall thickness of the carpet is approx. 22 mm and the weight is 3.8 kg/sqm. Colours orange, hemp or espresso.

Tapis
Tapis noué à la main en 100% laine néo-zélandaise. Bordure périmétrique nouée à la main avec du fil de laine. L'épaisseur totale du tapis est d'environ 22 mm et son poids est de 3,8 kg/m². Coloris orange, chanvre ou espresso.

Teppich
Handgeknüpfter Teppich aus 100% neuseeländischer Wolle. Handgeknüpfte Randeinfassung mit Wollgarn. Die Gesamtdicke des Teppichs beträgt ca. 22 mm und das Gewicht 3,8 kg/qm. Farben orange, hanf oder espresso.

Alfombra
Alfombra anudada a mano con lana 100% de Nueva Zelanda. Borde perimetral anudado a mano con hilo de lana. El grosor total de la alfombra es de aproximadamente 22 mm y el peso es de 3,8 kg/m². Colores naranja, cáñamo o espresso.

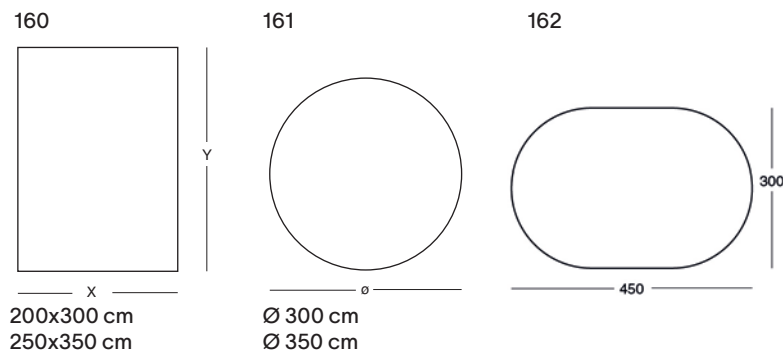

V-Bol 9562/9563



Design

Zaven

2025

Vaso
Vaso in argilla smaltata lucida colori rosa, blu scuro, rosso e bordeaux.

Vase
Vase in polished glazed clay, colours pink, dark blue, red and burgundy.

Vase
Vase en argile émaillée brillant dans les couleurs rose, bleu foncé, rouge et bordeaux.

Vase
Vase aus glänzendem emailliertem Ton in den Farben Rosa, dunkelblau, rot und burgunderrot.

Jarrón
Jarrón arcilla vidriada en colores rosa, azul oscuro, rojo y burdeos.

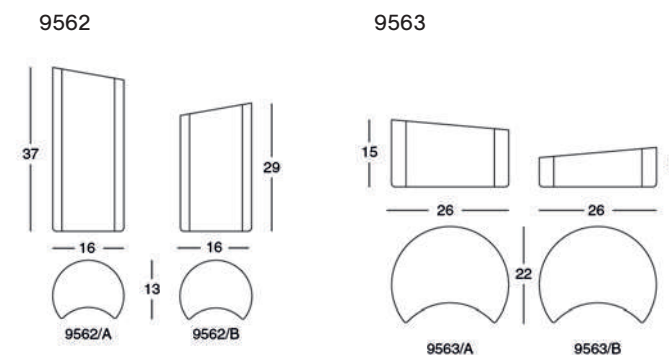



Design

Muller Van Severen

2025

Libreria

Struttura in acciaio verniciato lucido nei colori talco, caramello, arancione, amaranto, alga ed espresso. Piani in MDF impiallacciati in rovere verniciato colore naturale. Le versioni alte, se accostate, possono essere vincolate tramite giunto in dotazione.

Bookcase

Frame in polished painted steel, colour talc, caramel, orange, amaranth, algae and espresso. Shelves in MDF veneered in natural varnished oak. The high version bookcases, if placed side by side, can be linked by means of a joint provided.

Bibliothèque

Structure en acier verni poli, couleur talc, caramel, orange, amarante, algues et espresso. Étagères en MDF plaqué rouvre verni naturel. Les bibliothèques en version haute, si placées côte à côte, peuvent être reliées par un

Bücherregal

Gestell aus poliertem, lackiertem Stahl, in den Farben: Talkum, Karamell, Orange, Amarantröt, Algen und Espresso. Regale aus MDF, Eiche furniert naturfarben lackiert. Die Bücherregale hohe Version können, wenn sie nebeneinander gestellt sind, durch eine mitgelieferte Verbindungsgelenk miteinander verbunden werden.

Biblioteca

Estructura en acero pintado brillante, color talco, caramelo, naranja, granate, alga y espresso. Estantes en MDF chapados en roble barnizado natural. Las bibliotecas en versión alta, si se colocan una al lado de la otra, pueden unirse mediante una pieza de union en dotacion.

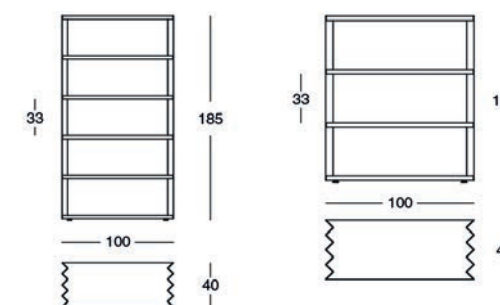

Struttura/Frame/Structure/ Gestell/Estructura



Sideboards



Contenitori
Containers
de rangement
Sideboards
Muebles
contenedores

236–243

Quaderna Cupboard ⁷⁵⁷

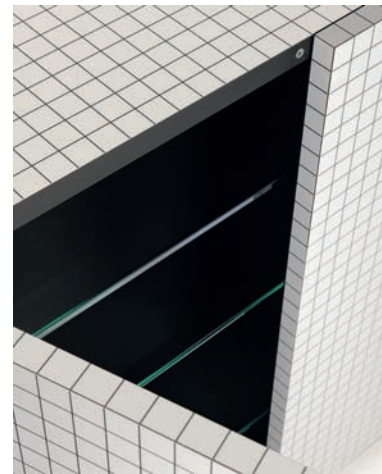

Design

Superstudio

1969-1972

Madia

Struttura in legno placcato laminato Print, colore bianco, a stampa digitale a quadretti neri con interasse di 3 cm. Placcatura interna in laminato colore nero. Ripiani interni regolabili in cristallo temperato.

Cupboard

Honeycomb core structure coated with white Print laminate, digitally printed with black squares at 3 cm spacing. Internal black laminate plating. Adjustable internal shelves in tempered plate glass.

Armoire

Structure en panneau alvéolaire plaqué en laminé Print couleur blanche, imprimé en digital à carrés noirs avec entraxe de 3 cm. Revêtement intérieur en stratifié noir. Plateaux intérieures réglables en verre trempé.

Schrank

Gestell aus Sperrholz mit weißem Print Laminat belegt. Digitaldruck mit kariertem Muster, Linienabstand 3 cm. Innen mit schwarzem Laminat überzogen. Verstellbare innere Regale aus gehärtetem Kristallglas.

Aparador

Estructura de madera aplacada con laminado Print, color blanco, a impresión digital en cuadrillos negros de 3 cm. Al interior esta chapado en laminado negro. Estantes interiores regulables de cristal templado.

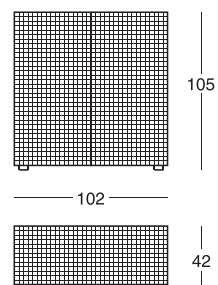

Quaderna Sideboard ⁷⁵⁶

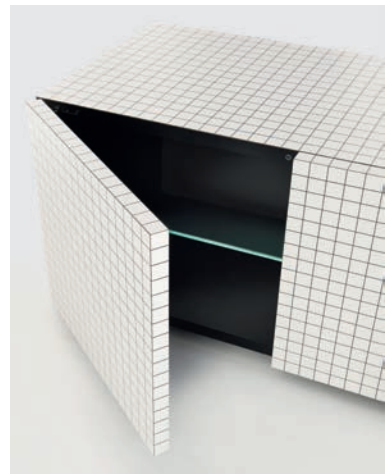
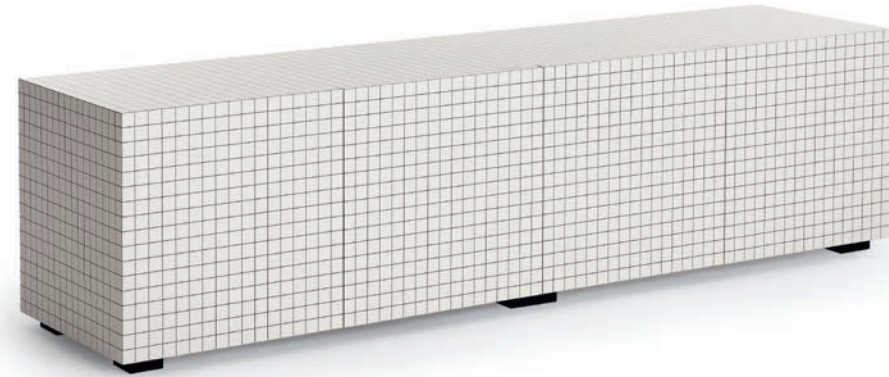

Design

Superstudio

1969-1972

Contenitore

Struttura in legno placcato laminato Print, colore bianco, a stampa digitale a quadretti neri con interasse di 3 cm. Placcatura interna in laminato colore nero. Ripiani interni regolabili in cristallo temperato. Sullo schienale, il contenitore è dotato di aperture passacavi.

Sideboard

Honeycomb core structure coated with white Print laminate, digitally printed with black squares at 3 cm spacing. Internal black laminate plating. Adjustable internal shelves in tempered plate glass. On the back panel, the sideboard is equipped with cable entries.

Container de rangement

Structure en panneau alvéolaire plaqué en laminé Print couleur blanche, imprimé en digital à carrés noirs avec entraxe de 3 cm. Revêtement intérieur en stratifié noir. Plateaux intérieures réglables en verre trempé. Sur le panneau arrière, le container est équipé des ouvertures pour câbles.

Sideboard

Gestell aus Sperrholz mit weißem Print Laminat belegt. Digitaldruck mit kariertem Muster, Linienabstand 3 cm. Innen mit schwarzem Laminat überzogen. Verstellbare innere Regale aus gehärtetem Kristallglas. Auf der Rückseite ist das Sideboard mit Öffnungen für Kabeldurchführung verstattet.

Mueble contenedor

Estructura de madera aplacada con laminado Print, color blanco, a impresión digital en cuadrillos negros de 3 cm. Al interior esta chapado en laminado negro. Estantes interiores regulables de cristal templado. En el panel trasero, el contenedor está equipado de agujeros de entrada para cables.

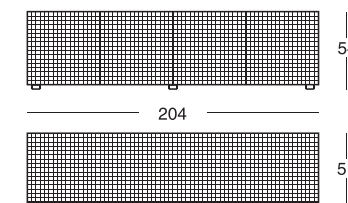

Riga-Riga 788

NEW FINISH



Design

Pierre Charpin

2025

Madia

Struttura in MDF impiallacciata in frassino laccato poro aperto nei colori nero e amaranto. Inserti in cristallo retro verniciato tono su tono o in combinazioni cromatiche chiuse: la versione nera può essere realizzata con cristalli neri, oppure con cristalli nei colori menta e cielo. La versione amaranto può essere realizzata con cristalli amaranto, oppure con cristalli nei colori avorio e corallo. Ripiani interni regolabili in cristallo extra-chiaro temperato. A richiesta, integrazione di illuminazione interna a LED a luce neutra.

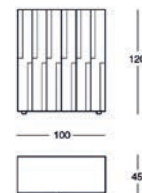

Cupboard

MDF frame veneered in open-pore lacquered ash in black or amaranth, available with back-painted tone-on-tone glass inserts or in specific colour combinations. The black version can be made either with black glass inserts, or with mint and sky glass inserts. The amaranth version can be made either with amaranth glass inserts, or with ivory and coral glass inserts. Adjustable internal shelves in tempered extra-clear glass. On request it is possible to integrate a neutral LED light source inside the cupboard.

Armoire

Structure en MDF plaqué frêne laqué à pores ouverts dans les couleurs noir ou rouge amarante, disponible avec des inserts en verre teintés ton sur ton au dos ou dans des combinaisons de couleurs unies. La version noire peut être réalisée avec des cristaux noirs, ou avec des cristaux de couleur menthe et ciel. La version rouge amarante peut être réalisée avec des cristaux amarante, ou avec des cristaux de couleur ivoire et corail. Plateaux intérieurs réglables en verre extra-clair trempé. Sur demande, il est possible d'intégrer une source de lumière LED neutre à l'intérieur de l'armoire.

Schrank

Gestell aus MDF, furniert mit offenporig lackierter Esche in Schwarz oder Amaranrot, erhältlich mit rückseitig lackierten, farblich abgestimmten Glaseinsätzen oder in einfarbigen Kombinationen. Die schwarze Version kann entweder mit schwarzen Kristalleinsätzen oder mit Kristallglaseinsätzen in den Farben Mint und Himmel sein. Die Amaranrot-Version kann entweder mit amaranroten Kristallglaseinsätzen oder mit Kristallglaseinsätzen in den Farben Elfenbein und Korallen sein. Verstellbare innere Regale aus gehärtetem, extraklarem Kristallglas. Auf Anfrage ist es möglich, eine neutrale LED-Lichtquelle im Schrank zu integrieren.

Aparador

Estructura en MDF chapada en fresno lacado a poro abierto en color negro o amaranto, disponible con inserciones de cristal pintadas por detrás en tonos a juego o en combinaciones de colores cerradas. La versión en negro puede fabricarse con inserciones de cristal en color menta y cielo. La versión en granate puede fabricarse con inserciones de cristal en tono granate o con inserciones de cristal en color marfil y coral. Estantes interiores regulables en cristal templado extraclaro. Sobre pedido, es posible integrar una fuente de luz LED neutra en el interior de l'aparador.



Riga-Riga 789

NEW FINISH



Design

Pierre Charpin

2025

Contenitore

Struttura in MDF impiallacciata in frassino laccato poro aperto nei colori nero e amaranto. Inserti in cristallo retro verniciato tono su tono o in combinazioni cromatiche chiuse: la versione nera può essere realizzata con cristalli neri, oppure con cristalli nei colori menta e cielo. La versione amaranto può essere realizzata con cristalli amaranto, oppure con cristalli nei colori avorio e corallo. Ripiani interni regolabili in cristallo extra-chiaro temperato. A richiesta, integrazione di illuminazione interna a LED a luce neutra.

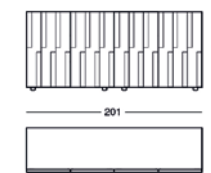

Sideboard

MDF frame veneered in open-pore lacquered ash in black or amaranth, available with back-painted tone-on-tone glass inserts or in specific colour combinations. The black version can be made either with black glass inserts, or with mint and sky glass inserts. The amaranth version can be made either with amaranth glass inserts, or with ivory and coral glass inserts. Adjustable internal shelves in tempered extra-clear glass. On request it is possible to integrate a neutral LED light source inside the cupboard.

Container de rangement

Structure en MDF plaqué frêne laqué à pores ouverts dans les couleurs noir ou rouge amarante, disponible avec des inserts en verre teintés ton sur ton au dos ou dans des combinaisons de couleurs unies. La version noire peut être réalisée avec des cristaux noirs, ou avec des cristaux de couleur menthe et ciel. La version rouge amarante peut être réalisée avec des cristaux amarante, ou avec des cristaux de couleur ivoire et corail. Plateaux intérieurs réglables en verre extra-clair trempé. Sur demande, il est possible d'intégrer une source de lumière LED neutre à l'intérieur de l'armoire.

Sideboard

Gestell aus MDF, furniert mit offenporig lackierter Esche in Schwarz oder Amaranrot, erhältlich mit rückseitig lackierten, farblich abgestimmten Glaseinsätzen oder in einfarbigen Kombinationen. Die schwarze Version kann entweder mit schwarzen Kristalleinsätzen oder mit Kristallglaseinsätzen in den Farben Mint und Himmel sein. Die Amaranrot-Version kann entweder mit amaranroten Kristallglaseinsätzen oder mit Kristallglaseinsätzen in den Farben Elfenbein und Korallen sein. Verstellbare innere Regale aus gehärtetem, extraklarem Kristallglas. Auf Anfrage ist es möglich, eine neutrale LED-Lichtquelle im Schrank zu integrieren.

Mueble contenedor

Estructura en MDF chapada en fresno lacado a poro abierto en color negro o granate, disponibles con inserciones de cristal pintadas por detrás en tonos a juego o en combinaciones de colores cerradas. La versión en negro puede fabricarse con inserciones de cristal negros o con inserciones de cristal en color menta y cielo. La versión en granate puede fabricarse con inserciones de cristal en tono granate o con inserciones de cristal en color marfil y coral. Estantes interiores regulables en cristal templado extraclaro. Sobre pedido, es posible integrar una fuente de luz LED neutra en el interior de l'aparador.



Z24 Cupboard ⁷²⁶



Design

Muller Van Severen

2024

Madia

Struttura in MDF e legno listellare, laccatura opaca nei colori talco, cera, canapa, caramello, arancione, amaranto, verde prato, alga, espresso e nero. Ripiani interni regolabili in cristallo temperato. A richiesta è possibile all'interno del vano integrare una fonte luminosa a led a luce neutra.

Cupboard

Frame in MDF and blockboard wood, matt lacquered in the colours talc, wax, hemp, caramel, orange, amaranth, grass green, algae, espresso and black. Adjustable internal shelves in tempered plate glass. On request, it is possible to integrate a neutral LED light source inside the cupboard.

Armoire

Structure en MDF et bois à lamelles, laquée mat dans les couleurs talc, cire, chanvre, caramel, orange, rouge amarante, vert pré, algues, espresso et noir. Plateaux intérieures réglables en verre trempé. Sur demande, il est possible d'intégrer une source de lumière LED neutre à l'intérieur de l'armoire.

Schrank

Gestell aus MDF und Lattenholz matt lackiert in den Farben Talkum, Wachs, Hanf, Karamell, Orange, Amaranrot, grasgrün, Algen, Espresso und schwarz. Verstellbare innere Regale aus gehärtetem Kristallglas. Auf Anfrage ist es möglich, eine neutrale LED-Lichtquelle im Schrank zu integrieren.

Aparador

Estructura de MDF y listones de madera, lacada mate en los colores talco, cera, cáñamo, caramelo, naranja, granate, verde prado, alga, espresso y negro. Estantes interiores regulables de cristal templado. Sobre pedido, es posible integrar una fuente de luz LED neutra en el interior de l'aparador.

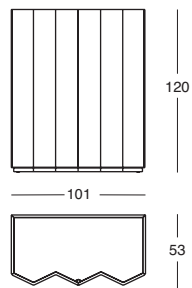

Struttura/Frame/Structure/ Gestell/Estructura



Z24 Sideboard ⁷²⁷



Design

Muller Van Severen

2024

Contenitore

Struttura in MDF e legno listellare, laccatura opaca nei colori talco, cera, canapa, caramello, arancione, amaranto, verde prato, alga, espresso e nero. Ripiani interni regolabili in cristallo temperato. A richiesta è possibile, all'interno del vano, integrare una fonte luminosa a led a luce neutra.

Storage unit

Frame in MDF and blockboard wood, matt lacquered in the colours talc, wax, hemp, caramel, orange, amaranth, grass green, algae, espresso and black. Adjustable internal shelves in tempered plate glass. On request, it is possible to integrate a neutral LED light source inside the storage unit.

Container de rangement

Structure en MDF et bois à lamelles, laquée mat dans les couleurs talc, cire, chanvre, caramel, orange, rouge amarante, vert pré, algues, espresso et noir. Plateaux intérieures réglables en verre trempé. Sur demande, il est possible d'intégrer une source de lumière LED neutre à l'intérieur del container.

Sideboard

Gestell aus MDF und Lattenholz matt lackiert in den Farben Talkum, Wachs, Hanf, Karamell, Orange, Amaranrot, grasgrün, Algen, Espresso und schwarz. Verstellbare innere Regale aus gehärtetem Kristallglas. Auf Anfrage ist es möglich, eine neutrale LED-Lichtquelle im Sideboard zu integrieren.

Mueble contenedor

Estructura de MDF y listones de madera, lacada mate en los colores talco, cera, cáñamo, caramelo, naranja, granate, verde prado, alga, espresso y negro. Estantes interiores regulables de cristal templado. Sobre pedido, es posible integrar una fuente de luz LED neutra en el interior del mueble.

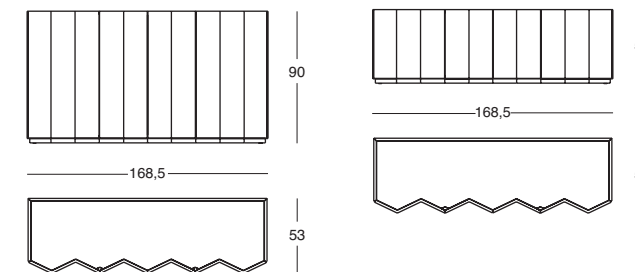

Struttura/Frame/Structure/ Gestell/Estructura



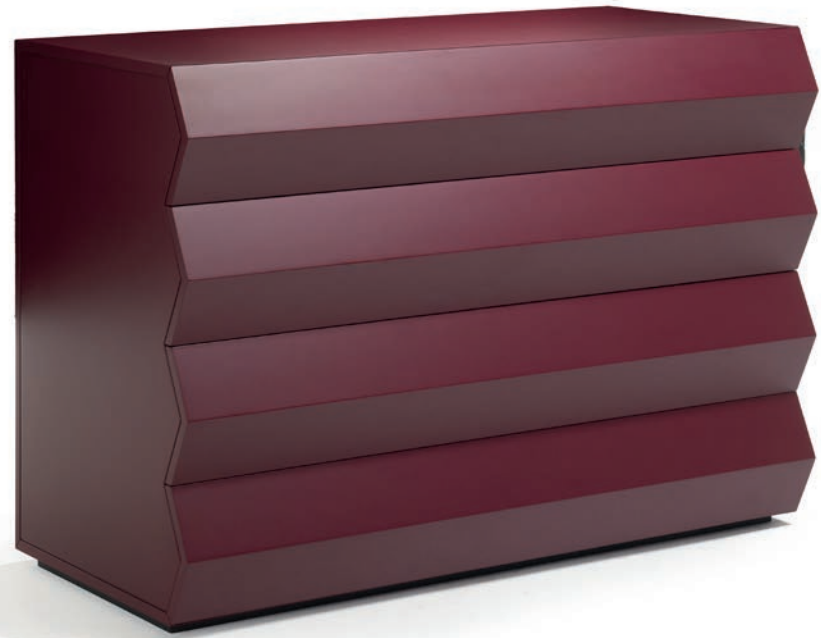

Design

Muller Van Severen

2025

Cassettiera

Struttura in MDF, laccatura opaca nei colori talco, cera, canapa, caramello, arancione, amaranto, verde prato, alga, espresso e nero.

Chest of drawers

MDF frame, matt lacquered in talc, wax, hemp, caramel, orange, amaranth, grass green, algae, espresso and black.

Commode

Structure en MDF, laqué mat dans les couleurs talc, cire, chanvre, caramel, orange, amarante, vert pré, algues espresso et noir.

Kommode

Gestell aus MDF, matt lackiert in den Farben Talkum, Wachs, Hanf, Karamell, Orange, Amarantröt, grasgrün, Algen, Espresso und schwarz.

Cómoda

Estructura en MDF, lacada mate en talco, cera, cáñamo, caramelo, naranja, granate, verde Prado, alga, espresso y negro.

785

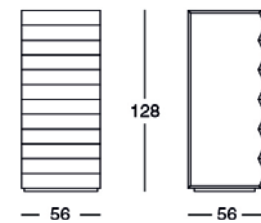

786

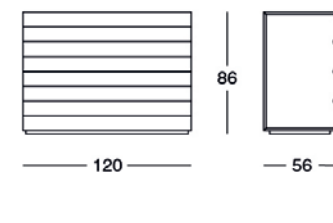

787

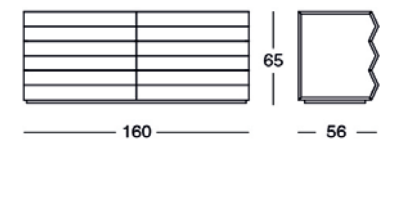

Struttura/Frame/Structure/ Gestell/Estructura

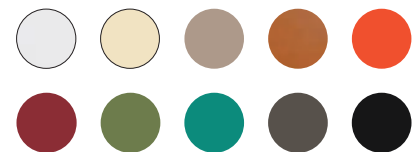

Mirrors

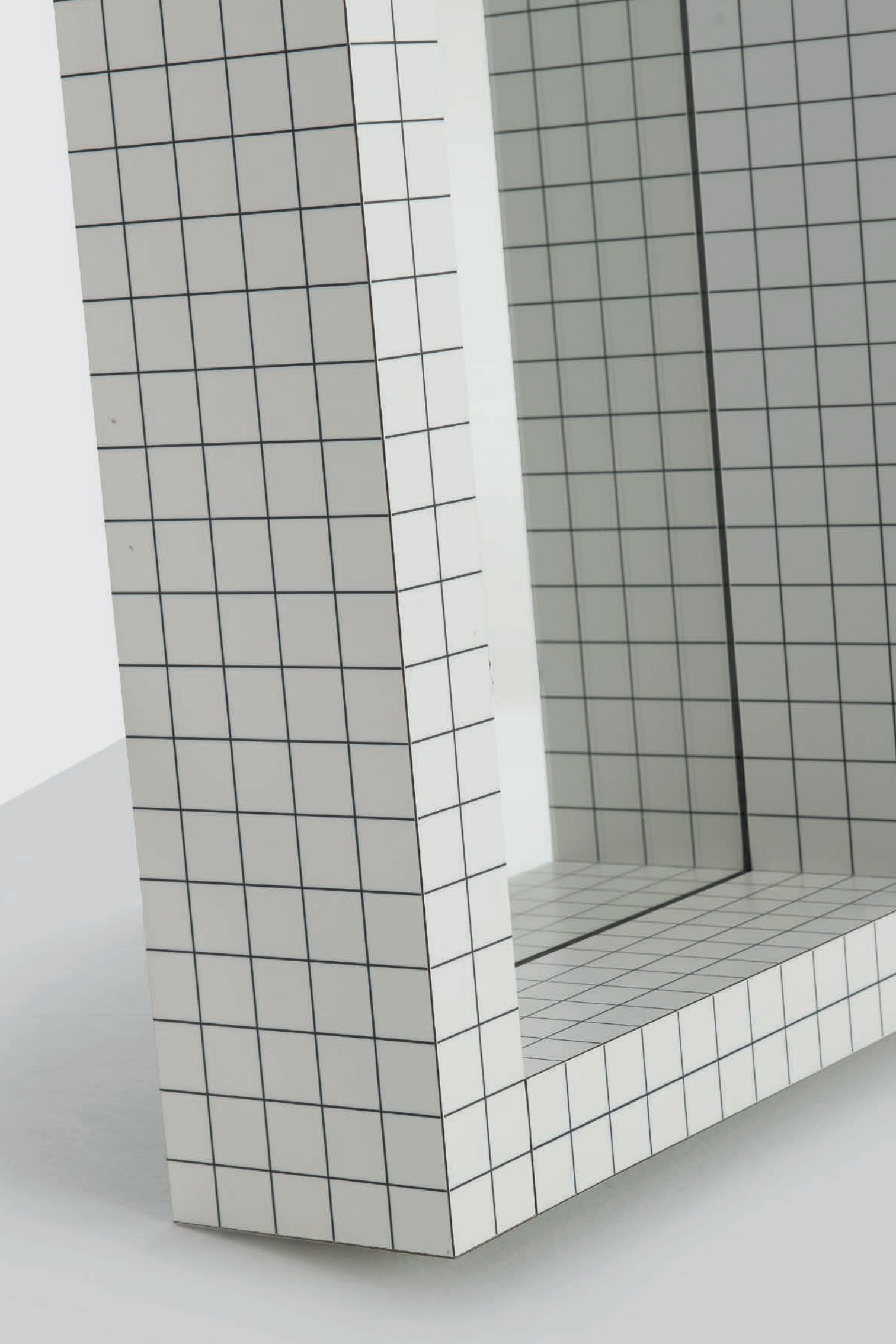

246–249

Specchi
Miroirs
Spiegel
Espejos



Design

Carlo Mollino

1938

Specchio

Silhouette della Venere di Milo in cristallo con nottolino in acciaio inox per il fissaggio a parete.

Mirror

Venus de Milo's silhouette plate glass, with stainless steel pawl for hanging.

Miroir

Silhouette de la Venus de Milo en verre avec attache en acier inox pour l'accrochage au mur.

Spiegel

Silhouette der Venus von Milo aus Kristallglas. Aufhängung aus Inox-Stahl.

Espejo

Silueta de la Venus de Milo de cristal con pletinas de acero inox para colgar el espejo a la pared.

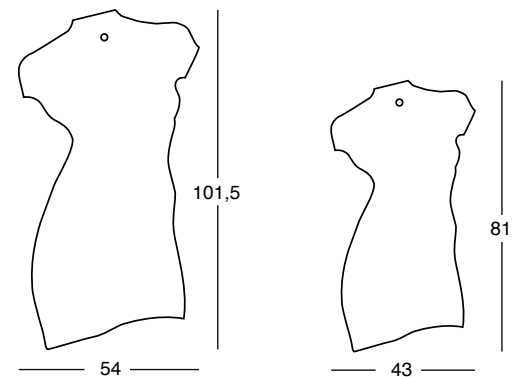

* Vedi nota a fine catalogo
 * See note at the end of the catalogue
 * Voir la note en fin de catalogue
 * Siehe Hinweis am Ende des Katalogs
 * Ver nota al final del catálogo

Design

Superstudio

1969-1972

Specchio

Cristallo spessore 5 mm. Cornice in legno placcato laminato Print, colore bianco, a stampa digitale a quadretti neri con interasse di 3 cm.

Mirror

5mm thick plate glass. Honeycomb core frame coated with white Print laminate, digitally printed with black squares at 3 cm spacing.

Miroir

Cristal de 5 mm d'épaisseur. Cadre en panneau alvéolaire plaqué en laminé Print, couleur blanche, imprimé en digital à carrés noirs avec entraxe de 3 cm.

Spiegel

5 mm. starkes Kristallglas. Rahmen aus Sperrholz mit weißem Print Laminat belegt. Digitaldruck mit kariertem Muster, Linienabstand 3 cm.

Espejo

Cristal, 5 mm de espesor. Marco de madera aplacada con laminado Print, color blanco, a impresión digital en cuadrillos negros de 3 cm.

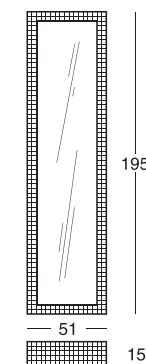

Raperonzolo ⁴⁷¹



Design

Atelier Oi

2015

Specchio
Superficie in cristallo. Il bordo dello specchio è in cuoio intrecciato colore gold accoppiato ad Alcantara® nei colori gold, blu e melanzana. Il fissaggio a parete è realizzato con una piastra in metallo bronzato.

Mirror
Plate glass surface. The mirror outline is made of cowhide in the shade of gold, interwoven with Alcantara® in the shades gold, blue and aubergine. Wall fastening by means of a bronzed metal plate.

Miroir
Surface en cristal. Le bord du miroir est en cuir sellier tressé dans la couleur gold couplé au Alcantara® dans les couleurs gold, bleu et aubergine. L'accrochage au mur est prévu à travers une plaque en métal bronzée.

Spiegel
Fläche aus Glasscheiben. Der Spiegel ist mit einem Zopf aus goldfarbenen Kernlederbänder umfasst, welche mit Alcantara® bzw. in den Farben Gold, Blau und Aubergine geflochten werden. Befestigung an der Wand mittels einer Platte aus bronziertem Metall.

Espejo
Superficie en cristal. El borde del espejo es en cuero trenzado en color gold acoplado con Alcantara® en los colores gold, azul y berenjena. Para colgar el espejo a la pared está prevista una placa en metal bronceado.

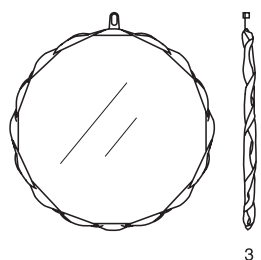

Ø 51
Ø 69
Ø 105

Sosia ⁸⁸⁵⁸



Design

Ugo La Pietra

1982

Specchio
Cristallo extra chiaro bisellato, decorato con stampa digitale, retro argentato. A richiesta è possibile, nella parte posteriore dello specchio, integrare una fonte luminosa a led a luce calda.

Mirror
Extra clear bevelled plate glass, decorated with digital printing, silver back. On request, it is possible to integrate a neutral warm LED light source at the rear of the mirror.

Miroir
Cristal extra clair biseauté, décoré avec impression digital, dos argenté. Sur demande, il est possible d'intégrer une source de lumière chaude LED à l'arrière du miroir.

Spiegel
Extra klares schräg-abgeschliffenes Kristallglas, mit Digitaldruck, silbere plateada. Auf Anfrage ist es möglich, eine warme LED-Lichtquelle auf der Rückseite des Spiegels zu integrieren.

Espejo
Cristal extra claro biselado, decorado con impresión digital, parte trasera plateada. Sobre pedido, es posible integrar una fuente de luz LED cálida en la parte trasera del espejo.

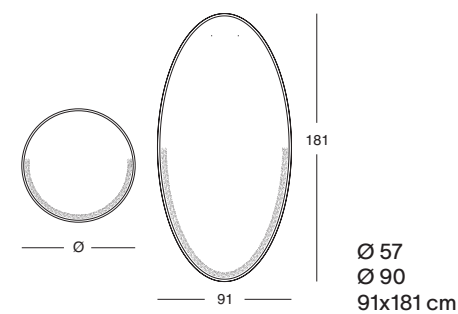

Ø 57
Ø 90
91x181 cm

Finiture / Finishes

Verniciatura Lucida/Glossy Varnish/Laquage Brillant/Glanzlackierung/Lacado Brillante

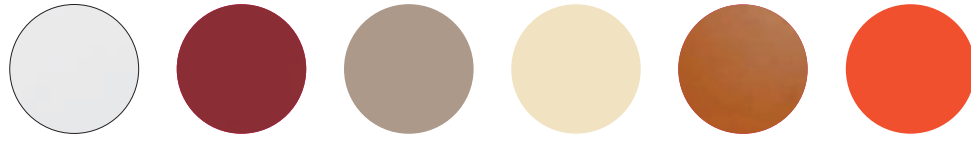

Talco/Talc/Talc/
Talkum/Talco

Amaranto/
Amaranth /
Rouge Amaranth /
Amarantrot/
Granate

Canapa/Hemp/
Chanvre/Hant/
Cañamo

Cera/Wax/Cire/
Wachs/Cera

Caramello
Caramel/Caramel/
Karamell/Caramelo

Arancione/
Orange/Orange/
Orange/Naranja



Verde prato/
Grass green/Vert
pré/Grasgrün/
Verde prado

Alga/Algae/
Algues/Algen/
Alga

Espresso/Espresso/
Espresso/Espresso/
Espresso

Nero/Black/Noir/
Schwarz/Negro

Verniciatura Opaca/Matt Varnish/Peinture Mat/Matte Lackierung/Pintura Mate



Talco/Talc/Talc/
Talkum/Talco

Amaranto/Amaranth
/Rouge Amaranth/
Amarantrot/Granate

Canapa/Hemp/
Chanvre/Hant/
Cañamo

Cera/Wax/Cire/
Wachs/Cera

Caramello/
Caramel/Caramel/
Karamell/Caramelo

Arancione/
Orange/Orange/
Orange/Naranja

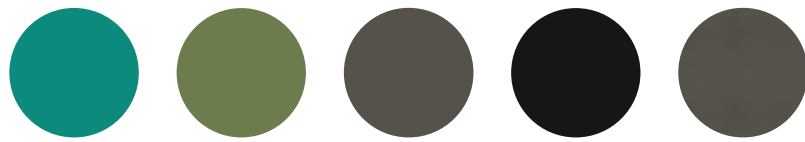

Verde prato/
Grass green/Vert
pré/Grasgrün/
Verde prado

Alga/Algae/
Algues/Algen/
Alga

Espresso/Espresso/
Espresso/Espresso/
Espresso

Nero/Black/Noir/
Schwarz/Negro

Grafite/Graphite/
Graphite/Graphit/
Grafito

Laminato/Laminate/Laminé/Laminat/Laminado

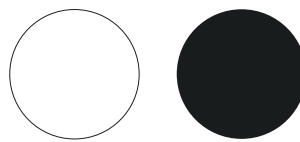

600
Bianco/White/
Blanc/Weiß/
Blanco

610
Nero/Black/Noir/
Schwarz/Negro

Nichelsatinatura/Nickel-satin finish/Nickelage satiné/Vernickeltes Finish/Niquelado satinado



Naturale opaca/Matt
natural/Naturel mat/
Naturfarben mattiert
/Natural mate

Nera opaca/Matt
black/Noir mat/
Schwarz mattiert/
Negro mate

Marmo/Marble/Marbre/Marmor/Marmól + Pietra/Stone/Pierre/Stein/Piedra

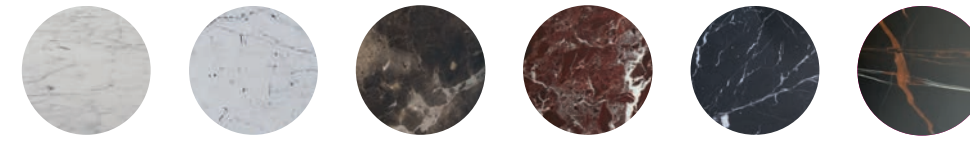

Calacatta grigio/
Grey Calacatta/
Gris Calacatta/
Gru Calacatta/
Gris Calacatta

Bianco di Carrara/
White Carrara/
Blanc Carrara/
Weiß Carrara/
Blanco Carrara

Emperador

Rosso Lepanto/
Red Lepanto/
Rouge Lepanto/
Rot Lepanto/Rojo
Lepanto

Marquinia

Sahara Noir

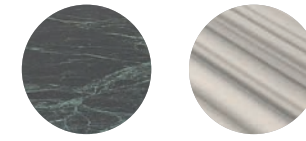

Verde Alpi/Green
Alpi/Vert Alpi/Grün
Alpi/Verde Alpi

Striato
Olimpico

Cemento/Cement/Ciment/Zement/Cemento



Polimex® rivestito in cemento con finitura
acrilica/Polimex® covered with acryl finish
cement/Polimex® revêtu en ciment avec
finition acrylique/Polimex® mit Zement
verkleidet und Akryl Finish/Polimex®
revestido en cemento, acabado acrilico

Cristallo/Plate glass/Verre/Kristallglas/Cristal

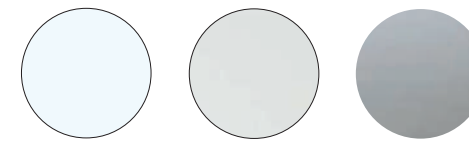

Cristallo
trasparente/Clear
plate glass/Verre
transparent/
Klares
Kristallglas/Cristal
transparente

Cristallo extra chiaro
trasparente/Extra-
clear plate glass/
Verre extra-clair
transparent/Extra
klares Kristallglas/
Cristal extraclaro
transparente

Cristallo fumé/
Smoky grey
plate glass/Verre
fumé gris/Grau
rauchfarbenes
Kristallglas/Cristal
gris humo

Essenza legno/Wood finish/Essence du bois/Holzart/Esencia de mader

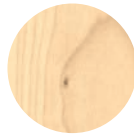

Acero/Maple/
Érable/Ahorn/
Arce



Betulla/Birch/
Bouleau/Birke/
Abedul



Faggio naturale/
Natural beech/
Hêtre naturel/
Naturfarbene
Buche /Haya
natural



Faggio evaporato/
Steam-treated
beech/Hêtre
évaporé/Gedampfte
Buche/Haya
vaporizada



Faggio laccato
bianco/White
varnished beech/
Hêtre teinté blanc/
Weiß gebeizte
Buche/Haya teñida
blanco

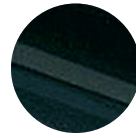

Faggio laccato
verde/Green
varnished beech/
Hêtre teinté vert/
Grün gebeizte
Buche/Haya teñida
verde

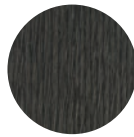

Frassino tinto grigio/
Grey varnished ash/
Frêne teinté gris/
Grau gebeiztes
Eschenholz/Fresno
teñido gris

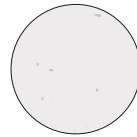

Frassino tinto talco/
Talc varnished ash/
Frêne teinté talc/
Talkum-gebeiztes
Eschenholz/Fresno
teñido talco



Frassino tinto nero/
Black varnished ash/
Frêne teinté noir/
Schwarz gebeiztes
Eschenholz/Fresno
teñido negro



Frassino tinto rovere
naturale/Natural
oak varnished ash/
Frêne teinté rouvre
naturel/Naturfarbene
Eiche gebeiztes
Eschenholz/Fresno
teñido roble natural

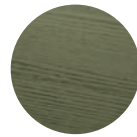

Frassino tinto alga/
Algae varnished ash/
Frêne teinté algues/
Algen-gebeiztes
Eschenholz/Fresno
teñido alga

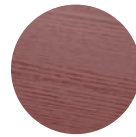

Frassino tinto
amaranto/Amaranth
varnished ash/
Frêne teinté
rouge amarante/
Amarantrot-
gebeiztes
Eschenholz/Fresno
teñido granate



Frassino tinto
espresso/Espresso
varnished ash/ Frêne
teinté espresso/
Espresso-gebeiztes
Eschenholz/Fresno
teñido espresso



Frassino tinto
caramello/Caramel
varnished ash/ Frêne
teinté caramel/
Karamell-gebeiztes
Eschenholz/Fresno
teñido caramelo



Frassino tinto moka/
Mocha varnished
ash/ Frêne teinté
moka/Mokka
gebeizte Esche/
Fresno teñido moka



Noce Canaletto/
Canaletto walnut/
Noyer Canaletto/
Nussbaum
Canaletto/Nogal
Canaletto



Rovere tinto
arancione/Orange
varnished oak/
Rouvre teinté
orange/Orange-
gebeizte Eiche/
Roble teñido naranja



Rovere naturale/
Natural oak/Rouvre
naturel/Naturfarbene
Eiche/Roble natural



Rovere tinto nero/
Black varnished
oak/Rouvre teinté
noir/Schwarz
gebeizte Eiche/
Roble teñido
negro



Rovere tinto noce
Canaletto/Canaletto
walnut dyed-oak/
Rouvre teinté noyer
Canaletto/Nussbaum
Canaletto-gebeizte
Eiche/Roble teñido
nogal Canaletto

Note – Carlo Mollino*

*Tutti i diritti di proprietà intellettuale su opere, disegni e documenti di Carlo Mollino sono di titolarità dello Stato Italiano ex art. 586 c.c. – Prodotto su licenza esclusiva – concessione dell'Agenzia del Demanio.

*All intellectual property rights on the works, drawings, and documents of Carlo Mollino are owned by the Italian State pursuant to Article 586 of the Italian Civil Code – Produced under exclusive license – granted by the Agenzia del Demanio.

*Tous les droits de propriété intellectuelle relatifs aux œuvres, dessins et documents de Carlo Mollino sont la propriété de l'État italien conformément à l'article 586 du Code civil italien – Produit sous licence exclusive – concession accordée par l'Agenzia del Demanio.

*Alle geistigen Eigentumsrechte an den Werken, Zeichnungen und Dokumenten von Carlo Mollino sind gemäß Artikel 586 des italienischen Zivilgesetzbuches Eigentum des italienischen Staates – Hergestellt unter exklusiver Lizenz – gewährt durch die Agenzia del Demanio.

*Todos los derechos de propiedad intelectual sobre las obras, dibujos y documentos de Carlo Mollino pertenecen al Estado italiano de conformidad con el artículo 586 del Código Civil italiano – Producido bajo licencia exclusiva – concedida por la Agenzia del Demanio.

zanotta:

Art direction
Calvi Brambilla

Graphic design
Tomo Tomo

Photo
Simone Barberis

Digital Images and Post Production
Pan Group Milano

Copyright© Zanotta SpA, 2026
All rights reserved

Zanotta Spa
I – 20834 Nova Milanese
Via Vittorio Veneto 57
T: + 39 0362 4981
zanottaspa@zanotta.it
www.zanotta.com

Zanotta Flagship Store
I – 20122 Milano
Via Durini 25-27
T +39 02 97073103
store.milano@zanotta.it

Zanotta Store Paris
F - 75007 Paris
242 Bd Saint-Germain
T +33 01 83 79 14 66
zanotta@silvera.fr



Zanotta è membro di Fondazione Altgamma che, dal 1992, riunisce i marchi dell'eccellenza italiana famosi a livello internazionale.

Zanotta is member of the Altgamma Foundation which, since 1992, has gathered together high-end Italian brands famous at international level.



Zanotta è certificata secondo le norme internazionali UNI EN ISO 9001 per i sistemi di gestione per la qualità e UNI ISO 45001 per la sicurezza e salute sui luoghi di lavoro.

Zanotta is certified according to international standards UNI EN ISO 9001 for the quality management systems and UNI ISO 45001 for the safety and health in the workplace.

Zanotta spa si riserva di apportare, senza preavviso, modifiche nei materiali, nei rivestimenti, nelle finiture e nei disegni dei prodotti presentati in questo catalogo. Le texture ed i colori dei materiali e delle finiture hanno valore indicativo in quanto soggetti alle tolleranze dei processi di stampa.

Zanotta spa reserves the right to change, without previous notice, materials, covers, finishes and drawings of the products presented in this catalogue. The textures and colours of materials and finishes are indicative as they are depending on the tolerances of the printing process.

Zanotta spa se réserve le droit d'apporter, sans préavis, des modifications au niveau des matériaux, des revêtements, des finitions et du design des produits présentés dans ce catalogue. Les textures et les couleurs des matériaux et des finitions sont une valeurs indicative parce-que ils changent selon la tolérance aux procédés d'imprimerie.

Zanotta spa behaltet sich vor, ohne Vorankündigung, Veränderungen an den Materialien, Bezügen, Finish und Zeichnungen der in diesem Katalog vorgestellten Produkte vorzunehmen. Die Texturen und Farben der Materialien und Finish haben einen hinweisenden Wert, da sie von den Toleranzen im Druckprozess abhängig sind.

Zanotta spa se reserva el derecho de aportar modificaciones de dibujo, materiales, acabados y tapicerías, sin que esté obligada a dar aviso anticipado. Las texturas y los colores de los materiales y de los acabados tienen solo un valor indicativo porque están sujetos a la tolerancia en los procesos de imprenta.

